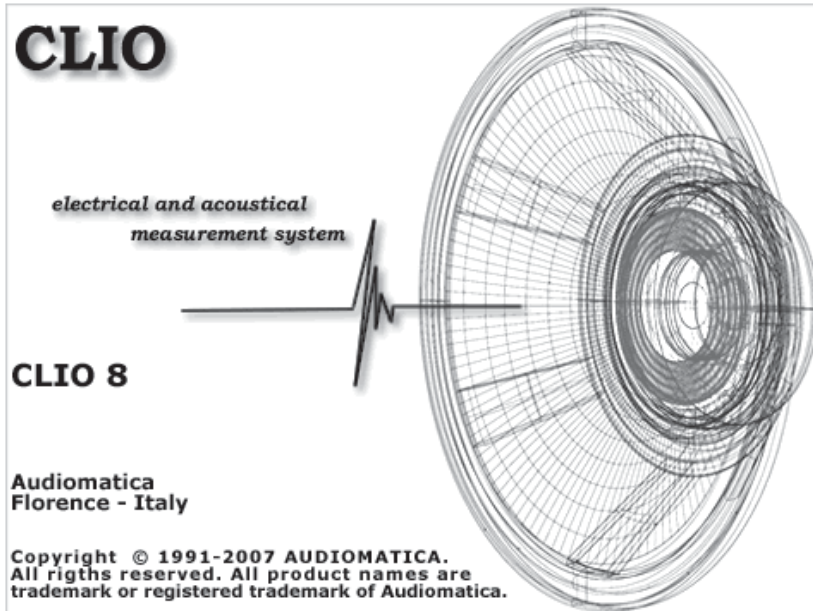


CLIO

ELECTRICAL & ACOUSTICAL TESTS



CLIO Software

Release 8
Version Standard

User's Manual



© Copyright 1991–2007 by AUDIOMATICA SRL

All Rights Reserved

Edition 8.00, May 2007

IBM is a registered trademark of International Business Machines Corporation.
Windows is a registered trademark of Microsoft Corporation.

CONTENTS

1 INTRODUCTION	11
1.1 ABOUT THIS MANUAL	11
1.1.1 WHAT THIS USER MANUAL DOES COVER	11
1.2 GENERAL CONDITIONS AND WARRANTY	11
2 THE CLIO SYSTEM	15
2.1 THE PB-4281 PC BOARD AND SC-02 SIGNAL CONDITIONER	16
2.2.1 COMBINED TECHNICAL SPECIFICATIONS	16
2.2 THE MIC-01 MICROPHONE	17
2.2.1 THE MIC-02 MICROPHONE	17
2.2.1 THE MIC-03 MICROPHONE	17
2.2.2 TECHNICAL SPECIFICATIONS	18
2.2.3 THE MIC-01 (OR MIC-02) FREQUENCY CALIBRATION DATA	18
2.2.4 THE MIC-01, MIC-02 or MIC-03 LITE MICROPHONE	18
2.3 THE PRE-01 MICROPHONE PREAMPLIFIER	19
2.3.1 TECHNICAL SPECIFICATION	19
2.3.2 USE OF THE PREAMPLIFIER	19
2.4 THE QCBOX MODEL 4 AMPLIFIER & SWITCH BOX	20
2.4.1 TECHNICAL SPECIFICATIONS	20
3 CLIO INSTALLATION	21
3.1 MINIMUM PC CONFIGURATION	21
3.2 HARDWARE INSTALLATION	21
3.2.1 INSTALLING THE PCI CARD	21
3.3 INSTALLING WINDOWS DRIVERS	21
3.3.1 PB4281 REGISTRATION UNDER WINDOWS 2000	21
3.3.2 PB4281 REGISTRATION UNDER WINDOWS XP	24
3.3.3 CONNECTING THE SC-02 UNIT & USB DRIVERS INSTALLATION	27
3.3.4 IMPORTANT ADVICE	29
3.4 SOFTWARE INSTALLATION	30
3.5 THE 'CLIO BOX'	31
3.6 RUNNING CLIO FOR THE FIRST TIME	32
3.6.1 INITIAL TEST	32
3.7 SYSTEM CALIBRATION	33
3.7.1 CALIBRATION VALIDATION	34
3.8 CLIO SERIAL NUMBER AND DEMO MODE	35
3.9 TROUBLESHOOTING CLIO INSTALLATION	36

4 CLIO BASICS 37

4.1 INTRODUCTION	37
4.2 GETTING HELP	37
4.3 CLIO DESKTOP	38
4.4 MAIN TOOLBAR	38
4.4.1 MEASUREMENT ANALYSIS	39
4.4.2 AUTOSCALE	39
4.4.3 HELP	39
4.5 HARDWARE CONTROLS TOOLBAR	40
4.5.1 INPUT CONTROL	40
4.5.2 INPUT/OUTPUT LOOPBACK	40
4.5.3 GENERATOR CONTROL	40
4.5.4 MICROPHONE CONTROL	42
4.5.5 CORRECTING THE MICROPHONE RESPONSE	43
4.6 EXTERNAL HARDWARE CONTROL	44
4.6.1 CONTROLLING THE CLIOQC AMPLIFIER & SWITCHBOX	44
4.6.2 CONTROLLING A TURNTABLE	45
4.7 MAIN MENU AND SHORTCUTS	46
4.7.1 FILE MENU	46
4.7.2 ANALYSIS MENU	47
4.7.3 CONTROLS MENU	51
4.7.4 WINDOWS MENU	52
4.7.5 HELP MENU	52
4.8 BASIC CONNECTIONS	53
4.8.1 CONNECTING THE CLIO BOX	53
4.8.2 CONNECTING A MICROPHONE	54
4.8.3 CONNECTING THE CLIOQC AMPLIFIER & SWITCHBOX	55

5 SYSTEM OPERATIONS AND SETTINGS 57

5.1 INTRODUCTION	57
5.2 REGISTERED FILE EXTENSIONS	57
5.3 FILE MENU AND MAIN TOOLBAR BUTTONS	59
5.3.1 LOADING AND SAVING FILES	59
5.3.2 EXPORTING DATA	60
5.3.3 EXPORTING GRAPHICS	61
5.3.4 PRINTING	62
5.4 OPTIONS	62
5.5 DESKTOP MANAGEMENT	64
5.6 CALIBRATION	65
5.7 STARTUP OPTIONS AND GLOBAL SETTINGS	65
5.7.1 SAVING MEASUREMENT SETTINGS	66

6 COMMON MEASUREMENT INTERFACE 67

6.1 INTRODUCTION	67
6.2 UNDERSTANDING THE DISPLAY IN FRONT OF YOU	67
6.3 BUTTONS AND CHECKBOXES	68
6.4 HOW TO ZOOM	68
6.5 SHORTCUTS AND MOUSE ACTIONS	69
6.6 THE MLS TIME DOMAIN DISPLAY	70

7 SIGNAL GENERATOR 71

7.1 INTRODUCTION	71
7.2 SINUSOID	71
7.3 TWO SINUSOIDS	73
7.4 MULTITONES	74
7.5 WHITE NOISE	75
7.6 MLS	76
7.7 CHIRPS	77
7.8 PINK NOISE	79
7.9 ALL TONES	81
7.10 SIGNAL FILES	83
7.10.1 SAVING SIGNAL FILES	85

8 MULTI-METER 87

8.1 INTRODUCTION	87
8.2 MULTI-METER CONTROL PANEL	87
8.2.1 TOOLBAR BUTTONS	88
8.2.2 TOOLBAR DROP DOWN LISTS	88
8.3 USING THE MULTI-METER	89
8.3.1 THE MINIMIZED STATE	89
8.3.2 CAPTURING THE GLOBAL REFERENCE LEVEL	89
8.4 THE SOUND LEVEL METER	91
8.4.1 CAPTURING THE MICROPHONE SENSITIVITY	91
8.5 THE LCR METER	93
8.5.1 MEASURING AN INDUCTOR	93
8.6 INTERACTION BETWEEN THE MULTI-METER AND FFT	94

9 FFT, RTA AND “LIVE” TRANSFER FUNCTION	95
9.1 INTRODUCTION	95
9.2 NARROWBAND FFT ANALYZER	95
9.2.1 TOOLBAR BUTTONS, DROP DOWN LISTS AND DISPLAYS	96
9.3 RTA - OCTAVE BANDS ANALYZER	97
9.3.1 DEDICATED TOOLBAR FUNCTIONS	97
9.4 FFT SETTINGS DIALOG	98
9.5 FFT AND RTA OPERATION	99
9.6 AVERAGING	103
9.7 TIME DATA DISPLAY (OSCILLOSCOPE)	104
9.8 FFT AND MULTI-METER	105
9.9 FFT AND Leq ANALYZER	105
9.10 “LIVE” TRANSFER FUNCTION ANALYZER	106
9.10.1 DEDICATED ‘LIVE’ TOOLBAR FUNCTIONS	106
9.10.2 USING CLIO DURING A LIVE PERFORMANCE	107

10 MLS & LOG CHIRP **111**

10.1 INTRODUCTION	111
10.2 MLS & LOG CHIRP CONTROL PANEL	111
10.2.1 TOOLBAR BUTTONS	112
10.2.2 TOOLBAR DROP DOWN LISTS	112
10.2.3 MLS & LOG CHIRP SETTINGS DIALOG	113
10.2.4 MLS & LOG CHIRP POST-PROCESSING TOOLS	114
10.3 IMPULSE RESPONSE CONTROL PANEL	115
10.3.1 TOOLBAR BUTTONS	115
10.4 MEASURING FREQUENCY RESPONSE	116
10.4.1 MEASUREMENT LEVEL	116
10.4.2 MLS & LOG CHIRP SIZE	116
10.4.3 ACOUSTIC FREQUENCY RESPONSE	118
10.4.4 PHASE & GROUP DELAY	122
10.5 OTHER TIME DOMAIN INFORMATION	126
10.6 PROCESSING TOOLS BY EXAMPLE	127
10.7 MLS Vs. LOG CHIRP	130
10.8 RELATED MENUS	132

11 SINUSOIDAL 133

11.1 INTRODUCTION	133
11.2 SINUSOIDAL CONTROL PANEL	133
11.2.1 TOOLBAR BUTTONS	133
11.2.2 TOOLBAR DROP DOWNS	134
11.2.3 SINUSOIDAL SETTINGS DIALOG	135
11.2.4 SINUSOIDAL POST PROCESSING TOOLS	137
11.3 A BRIEF DESCRIPTION ON SETTINGS EFFECTS	138
11.3.1 STEPPED VS. NOT STEPPED	138
11.3.2 FREQUENCY RESOLUTION	139
11.3.3 GATING	140
11.4 DISTORTION AND SETTINGS	142

12 WATERFALL AND DIRECTIVITY 145

12.1 INTRODUCTION	145
12.2 WATERFALL AND DIRECTIVITY CONTROL PANEL	146
12.2.1 COMMON TOOLBAR BUTTONS AND DROP DOWN LISTS	146
12.3 WATERFALL SPECIFIC CONTROLS	147
12.3.1 WATERFALL SETTINGS	147
12.3.2 WATERFALL OPERATION	148
12.4 MAKING A CUMULATIVE SPECTRAL DECAY	149
12.5 DIRECTIVITY SPECIFIC CONTROLS	152
12.5.1 DIRECTIVITY SETTINGS AND OPERATION	152
12.6 MEASURING AND REPRESENTING LOUDSPEAKER POLAR DATA	154
12.6.1 PREPARING AUTOSAVE AND THE MLS CONTROL PANEL	154
12.6.2 PREPARING THE TURNTABLE	154
12.6.3 TAKING THE MEASUREMENTS	155
12.6.4 REPRESENTING POLAR DATA	156

13 MEASURING IMPEDANCE AND T&S PARAMETERS 159

13.1 INTRODUCTION	159
13.2 GENERALS	159
13.3 INTERNAL MODE	159
13.3.1 MEASURING IMPEDANCE OF LOUDSPEAKERS	161
13.3.2 SETTING THE RIGHT LEVEL	161
13.3.3 DEALING WITH ENVIRONMENTAL NOISE	162
13.3.4 DEALING WITH VIBRATIONS	163
13.4 I SENSE	164
13.5 CONSTANT VOLTAGE & CONSTANT CURRENT	165
13.5.1 CONSTANT VOLTAGE	165
13.5.2 CONSTANT CURRENT	167
13.6 IMPEDANCE: SINUSOIDAL OR MLS	169
13.7 THIELE & SMALL PARAMETERS	170
13.7.1 INTRODUCTION	170
13.7.2 T&S PARAMETERS CONTROL PANEL	170
13.7.3 GLOSSARY OF SYMBOLS	171
13.7.3 T&S STEP BY STEP	172
13.7.4 USING LSE (LEAST SQUARE ERROR)	174

14 LINEARITY & DISTORTION	175
14.1 INTRODUCTION	175
14.2 LINEARITY & DISTORTION CONTROL PANEL	175
15 ACOUSTICAL PARAMETERS	179
15.1 INTRODUCTION	179
15.2 THE ACOUSTICAL PARAMETERS CONTROL PANEL	179
15.2.1 TOOLBAR BUTTONS AND DROP DOWN LISTS	180
15.2.3 INTERACTION WITH THE A.P. CONTROL PANEL	181
15.3 ACOUSTICAL PARAMETERS SETTINGS	182
15.4 THE CALCULATED ACOUSTICAL PARAMETERS	183
15.5 NOTES ABOUT ACOUSTICAL PARAMETERS MEASUREMENT	185
16 Leq LEVEL ANALYSIS	187
16.1 INTRODUCTION	187
16.2 THE Leq CONTROL PANEL	187
16.2.1 TOOLBAR BUTTONS AND DROP DOWN LISTS	188
16.2.3 INTERACTION WITH THE Leq CONTROL PANEL	189
16.3 Leq SETTINGS	190
17 WOW AND FLUTTER	191
17.1 INTRODUCTION	191
17.2 WOW & FLUTTER CONTROL PANEL	191
17.2.1 TOOLBAR BUTTON	191
17.2.2 TOOLBAR DROP DOWN LIST	191
17.3 FEATURES	192
18 WAVELET ANALYSIS	195
18.1 INTRODUCTION	195
18.2 WAVELET ANALYSIS CONTROL PANEL	196
18.2.1 COMMON TOOLBAR BUTTONS AND DROP DOWN LISTS	196
18.3 WAVELET ANALYSIS SETTINGS	197
18.4 WAVELET ANALYSIS OPERATION	198
18.4.1 TRADING BANDWIDTH AND TIME RESOLUTION	198
18.4.2 NORMALIZED SCALOGRAMS	200

BIBLIOGRAPHY 203

NORMS..... 205

1 INTRODUCTION

1.1 ABOUT THIS MANUAL

This User's Manual explains the CLIO system hardware and CLIO 8 software.

All software versions are covered, please note that CLIO 8 software is designed to operate in conjunction with the supplied PC boards. If these boards are absent or the serial numbers do not correspond then CLIO 8 will operate in **demo mode** only.

1.1.1 WHAT THIS USER MANUAL DOES COVER

The CLIO System is a complete electro-acoustic analyzer. There are thousands of books on many of the topics that CLIO handles as a measurement system. The simple definition of Frequency Response could be extended to a book itself. This User Manual is intended only as a **guide** to allow the user to quickly become efficient in using the CLIO system, its user interface, its hardware features and limits. Every topic is handled through real life examples with dozens of actual measurement being presented for clarity. It is therefore a HOW TO manual; WHY is left to the reader to explore through other literature and should be considered as essential reading. There is however reference [1], 'Testing Loudspeakers' by Joseph D'Appolito, which, in our opinion, is the perfect complement of what is covered here. Anyone who feels that WHY and HOW is strongly related should seriously consider buying this wonderful book.

1.2 GENERAL CONDITIONS AND WARRANTY

THANKS

Thank you for purchasing your CLIO system. We hope that your experiences using CLIO will be both productive and satisfying.

CUSTOMER SUPPORT

Audiomatica is committed to supporting the use of the CLIO system, and to that end, offers direct support to end users. Our users all around the world can contact us directly regarding technical problems, bug reports, or suggestions for future software enhancements. You can call, fax or write to us at:

AUDIOMATICA SRL
VIA MANFREDI 12
50136 FLORENCE, ITALY
PHONE: +39-055-6599036
FAX: +39-055-6503772

AUDIOMATICA ON-LINE

For any inquiry and to know the latest news about CLIO and other Audiomatica's products we are on the Internet to help you:

AUDIOMATICA website: www.audiomatica.com

E-MAIL: info@audiomatica.com

AUDIOMATICA'S WARRANTY

Audiomatica warrants the CLIO system against physical defects for a period of one year following the original retail purchase of this product. In the first instance, please contact your local dealer in case of service needs. You can also contact us directly as outlined above, or refer to other qualified personnel.

WARNINGS AND LIMITATIONS OF LIABILITY

Audiomatica will not assume liability for damage or injury due to user servicing or misuse of our product. Audiomatica will not extend warranty coverage for damage of the CLIO system caused by misuse or physical damage. Audiomatica will not assume liability for the recovery of lost programs or data. The user must assume responsibility for the quality, performance and the fitness of Audiomatica software and hardware for use in professional production activities.

The CLIO SYSTEM, CLIOfw, CLIOQC and AUDIOMATICA are registered trademarks of Audiomatica SRL.

REGISTRATION CARD

AUDIOMATICA REGISTRATION CARD
(EMAIL OR FAX TO US)

CLIO SERIAL NUMBER: _____

SOFTWARE VERSION: _____

PURCHASE DATE: _____

NAME: _____

JOB TITLE: _____

COMPANY: _____

ADDRESS: _____

ZIP OR POST CODE: _____

PHONE NUMBER: _____

FAX NUMBER: _____

E-MAIL: _____

2 THE CLIO SYSTEM

Depending on the hardware options that have been purchased, the CLIO system consists of some of the following components:

- The PB-4281 PCI PC board and SC-02 signal conditioner
- The MIC-01 or MIC-02 or MIC-03 (also **Lite**) microphones
- The PRE-01 microphone preamplifier
- The ClioQC Amplifier & Switch Box

In the next few pages we will describe each component and give its respective technical specifications.

NOTE: Audiomatica reserves the right to modify the following specifications without notice.

2.1 THE PB-4281 PC BOARD AND SC-02 SIGNAL CONDITIONER



The PB-4281 PC board and SC-02 Signal Conditioner form a high precision two channel A/D-D/A audio front-end for your IBM or compatible PC.

The PB-4281 PC board is housed in a standard PCI slot inside your computer and performs precise 18-bit digitizing of the signals to be analyzed.

The SC-02 Signal Conditioner is software controlled via an USB serial link; it is equipped with instrument grade input and output analog circuitry with an exceptionally wide range of output attenuation and input gain that allows an easy interface to the outside world; the input and output loop-back capability with the internal ultra stable voltage reference permits a simple and precise calibration of the whole instrument; the two input channels can be controlled separately or as a single balanced one.

A switchable phantom supply lets you directly connect an Audiomatica MIC-01 or MIC-02 or MIC-03 microphone to any of the SC-02 inputs.

It is also possible to superimpose a DC voltage to the generated AC signal.

2.2.1 COMBINED TECHNICAL SPECIFICATIONS

GENERATOR

Two channels 18 Bit sigma-delta D/A Converter

Frequency range: 1Hz-22kHz

Frequency accuracy: >0.01%

Frequency resolution: 0.01 Hz

Output impedance: 150 Ohm

Max output level (Sine): 12dBu (3.1 V RMS)

Output DC (Ch. A): $\pm 2.5V$

Attenuation: 0.1 dB steps to full mute

THD+Noise (Sine): 0.01%

ANALYZER

Two channels 18 bit sigma-delta A/D Converter

Input range: $+40 \div -40dBV$

Max input acceptance: +40dBV (283Vpp)

Input impedance: 64 kOhm (5.6 kOhm mic)

Phantom power supply: 8.2V

PC SYSTEM RESOURCES

One free IRQ

One free USB port

MISCELLANEOUS

Sampling frequency: 48kHz \div 8kHz

Card type: 12cm. PCI slot card

Audio connections: four RCA plugs

2.2 THE MIC-01 MICROPHONE



The MIC-01 microphone is an electret measuring microphone that is particularly well suited to being used in conjunction with the other components of the CLIO system. It is furnished with its own stand adaptor and a calibration chart reporting the individually measured sensitivity, all fitted in an elegant case. Its long and thin shape renders it ideal for anechoic measurements. Because its frequency response is very flat over the entire audio band, no particular correction is usually needed.

2.2.1 THE MIC-02 MICROPHONE



The MIC-02 microphone is functionally identical to MIC-01. It differs only in the fact that its length is 12 cm instead 25 cm. The MIC-02 is more practical to handle and to work with, and is ideal for measurements in a reverberant environment.

2.2.1 THE MIC-03 MICROPHONE

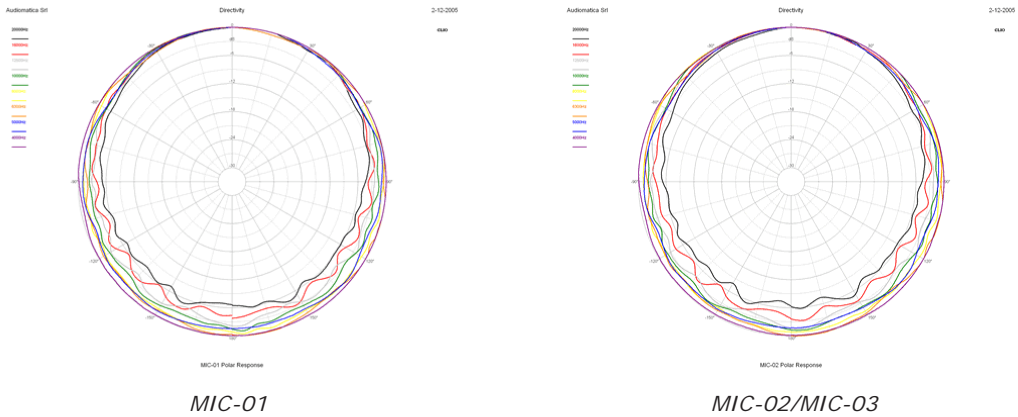


The MIC-03 microphone is functionally identical to MIC-01. It differs only in the fact that its length is 7 cm instead 25 cm. The MIC-03 is more convenient where space saving is a must.

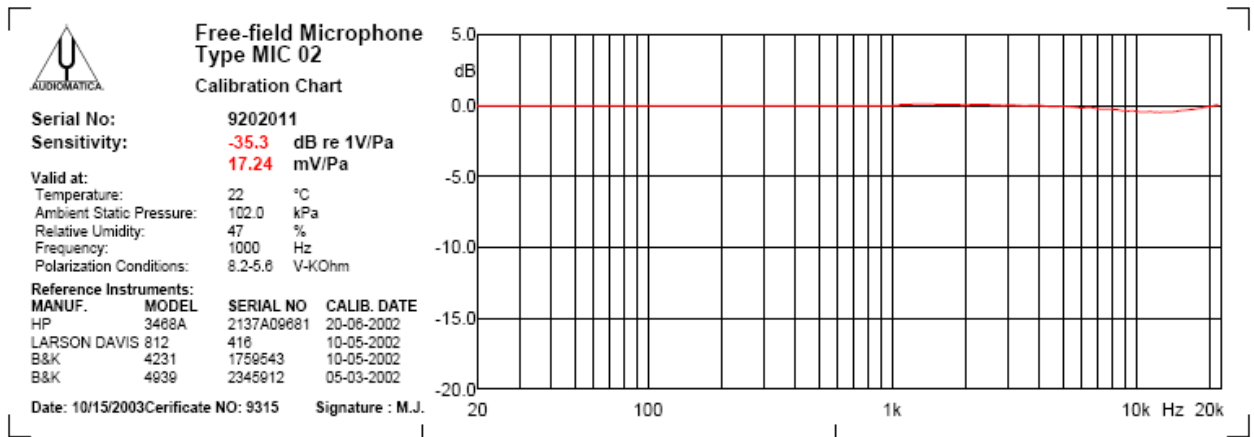
2.2.2 TECHNICAL SPECIFICATIONS

MIC-01

Type: Condenser electret
 Accuracy: ± 1 dB, 20 Hz to 10 kHz
 ± 2 dB, 10 kHz to 20 kHz (direct field)
 Maximum level: 130 dB SPL
 Dimensions: 8 mm diameter, 25 cm long
 Accessories: wooden case, 2.7 m cable, stand adaptor
 MIC-02: Same as MIC-01, but 12 cm long.
 MIC-03: Same as MIC-01, but 7 cm long.
 Polar Response:



2.2.3 THE MIC-01 (OR MIC-02) FREQUENCY CALIBRATION DATA



The microphones MIC-01 and MIC-02 can be furnished with (or be submitted for) a frequency calibration certificate. This document, along with numerical data on floppy disk, is released by Audiomatica and specifies the frequency behavior of the single microphone under test. The file data can be used with the CLIOwin software (see 4.5.5).

2.2.4 THE MIC-01, MIC-02 or MIC-03 LITE MICROPHONE

In the **Lite** version of MIC-01, MIC-02 and MIC-03 the accessories (wooden case, 2.7 m cable and stand adaptor) are not supplied. The microphone comes as in figure.



2.3 THE PRE-01 MICROPHONE PREAMPLIFIER



The microphone preamplifier PRE-01 has been designed to match Audiomatica's microphones MIC-01, MIC-02 and MIC-03. It is particularly useful when the microphone has to be operated far from the analyzer or when weighted measurements are needed. PRE-01 powers the microphone connected to its input with an 8.2V phantom supply and adds a selectable weighting filter (A or B or C); also available there is a 20 dB gain stage. The unit is operated with one standard 9V battery or with an external DC power supply.

2.3.1 TECHNICAL SPECIFICATION

Frequency response:	7Hz÷110kHz (-3dB)
Weighting filter:	A, B, C (IEC 651 - TYPE I)
Phantom power supply:	8.2V (5600 Ohm)
Gain:	0 & 20dB (INTERNAL SETTINGS)
Input impedance:	5600 Ohm
Output impedance:	100 Ohm
Maximum output voltage (@1kHz):	25 Vpp
THD (@1kHz):	0.01%
Input noise (@20dB gain):	7uV LIN, 5.3uV A
Drive capability:	±7mA
Batteries duration:	>24h (alkaline cell)
Size:	12.5(w)x19(d)x5(h)cm
Weight:	900g

2.3.2 USE OF THE PREAMPLIFIER

The MIC-01 or MIC-02 or MIC-03 microphone cable should be connected to the preamplifier input while the preamplifier output requires connection to the analyzer input. The unit is switched on with the POWER switch, while the TEST push-button controls the state of the unit. Correct operation of the unit is indicated by the led light being illuminated, if the LED fails to illuminate then either the batteries are low or the external power supply is not connected. The FILTER switch inserts the weighting filter. To choose the desired weighting filter type and to set the amplifier gain you have to modify the unit settings with the dip switch operated from the back panel.

NOTE: if the 20 dB gain stage is inserted the overall sensitivity (microphone + pre) is 10 times higher. For example if your microphone has a sensitivity of 17.1 mV/Pa and you amplify it by 20 dB then you get a sensitivity of 171 mV/Pa.

2.4 THE QCBOX MODEL 4 AMPLIFIER & SWITCH BOX



The QCBOX Model 4 amplifier and switch box is of invaluable help when configuring an automatic or manual quality control setup, or even in everyday laboratory use. Its main feature is the possibility of **internal switching** that permits the measurement of the impedance and frequency response of the loudspeaker connected to its output sockets without changing the wiring to the speaker; it is also possible to choose one of four inputs for the response measurements; the internal switching is under software control via the parallel port of the PC. A dedicated output, ISENSE, allows impedance measurements in constant voltage mode as well as voice coil current distortion analysis. A dedicated input permits an external foot pedal switch to be connected and trigger QC operations.



2.4.1 TECHNICAL SPECIFICATIONS

Inputs:	Four line/microphone inputs with selectable phantom power supply (8.2V) One TTL input for external trigger
Functions:	TTL controlled internal switches for impedance measurements
Output power:	50W (80hm) with current sensing
THD (@1 kHz):	0.004 %
Dimensions:	23(w)x23(d)x4(h)cm
Weight:	1.4kg
AC:	90 ÷ 240V

3 CLIO INSTALLATION

3.1 MINIMUM PC CONFIGURATION

The CLIO PB4281 PC board (and its companion SC-02 Signal Conditioner) running the CLIO software can be installed in any personal computer with the following minimum system requirements:

- Pentium III processor (suggested minimum 450 MHz)
- One free PCI slot
- One free USB port
- 128 MB RAM
- 1024x768 video adapter
- Microsoft Windows 2000 or XP
- Adobe Acrobat Reader

3.2 HARDWARE INSTALLATION

3.2.1 INSTALLING THE PCI CARD

To install the CLIO PB4281 card in your computer you should follow the instructions given below:

- 1) Disconnect the mains power cable from the PC.
- 2) Open the computer cabinet.
- 3) With the motherboard in front of you, identify a free **PCI** slot. Note that it is preferable to install the CLIO board as far away as possible from the video adapter.
- 4) Insert the CLIO board in the slot and screw it down firmly.
- 5) Close the cabinet.
- 6) Reconnect the mains cable but still **don't** connect the SC-02 Signal Conditioner. This topic will be covered in 3.3.3.

3.3 INSTALLING WINDOWS DRIVERS

The hardware registration procedure is started automatically the first time you switch your computer on, after you have physically installed the CLIO PB4281 PCI card.

At the end of this procedure you will deal with SC-02 connections and USB drivers installation.

If you are installing under:

- Windows 2000 go to section 3.3.1.
- Windows XP go to section 3.3.2.

3.3.1 PB4281 REGISTRATION UNDER WINDOWS 2000

The procedures described refer specifically (and are described with examples and figures) to the Windows 2000 Professional operating system, English version, they can be applied with appropriate translations to all languages.

LET'S NOW SWITCH THE PC ON!

As soon as Windows is started the 'Found New Hardware Wizard' automatically detects the CLIO card:



Figure 3.1

You will then be prompted with the dialog boxes in Fig.3.2. Press 'Next' and then select 'Search for a suitable driver for my device (Recommended)'.

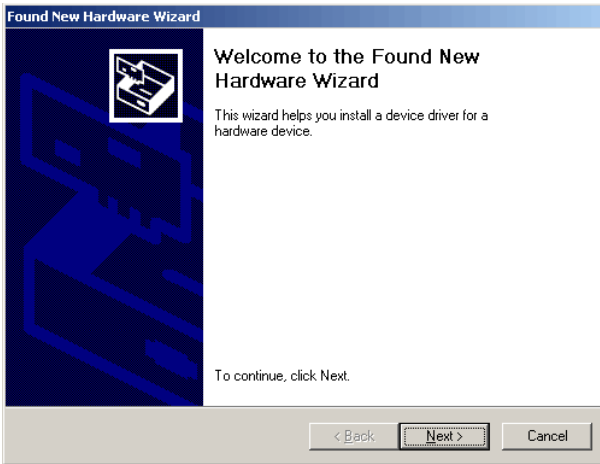


Figure 3.2

At the successive prompt Select 'Specify a location', then insert the CLIO CD-ROM in the CD-ROM drive and press the 'Browse...' button. Choose the CLIO2K.INF file inside the \INF2K directory inside the CD-ROM (see Fig.3.3).

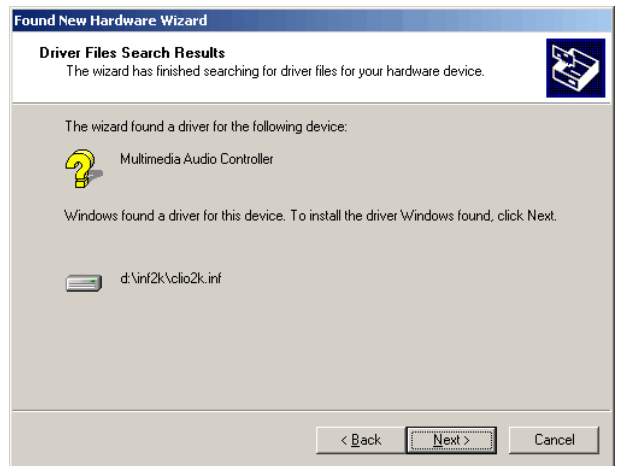
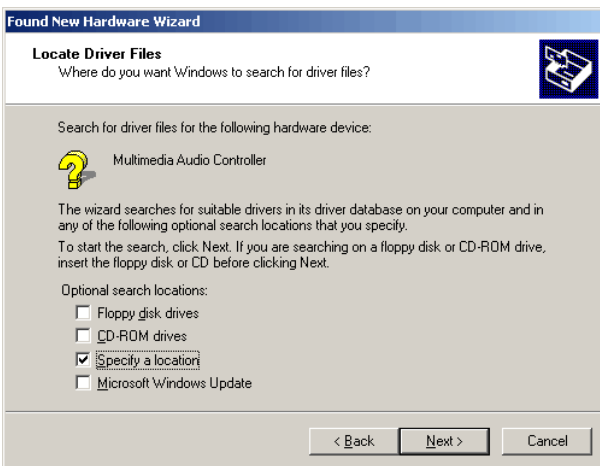


Figure 3.3

Ignore Microsoft's warning message about Digital Signature, answer 'Yes' to the prompt and reach the end of the wizard.

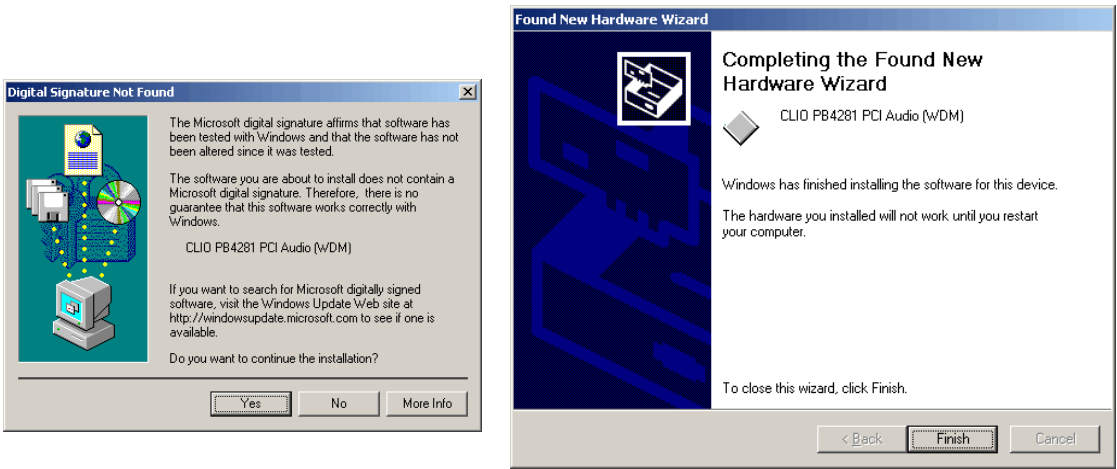


Figure 3.4

Let's now verify that the hardware installation and registration is OK.

Click with the **right** mouse button on the 'My Computer' icon on the Windows desktop. Then click 'Properties', select the 'Hardware' tab and press the 'Device Manager' button as in Fig. 3.5.

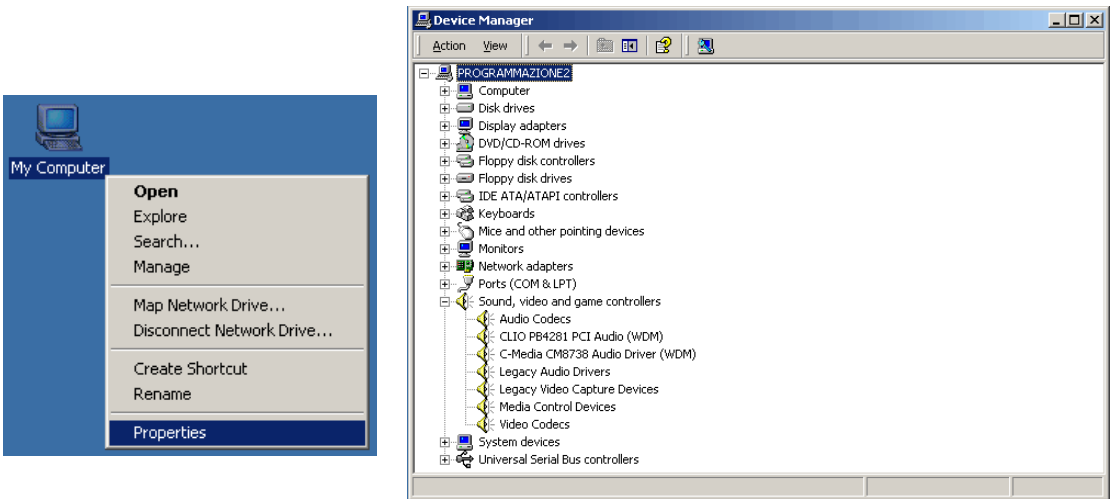


Figure 3.5

The presence of the 'CLIO PB4281 PCI Audio (WDM)' under 'Sound, video and game controllers' confirms the correct installation.

3.3.2 PB4281 REGISTRATION UNDER WINDOWS XP

The procedures described refer specifically (and are described with examples and figures) to the Windows XP Professional operating system, English version, they can be applied with only minor modifications and appropriate translations to all languages and to Windows XP Home.

LET'S NOW SWITCH THE PC ON!

As soon as Windows is started the 'Found New Hardware Wizard' automatically detects the CLIO card:



Figure 3.6

Windows XP is the only operating system that is able to install a driver for the CLIO card, the problem is that **it is not the correct one and needs to be updated.**

Let's now check what driver XP installed. Click with the **right** mouse button on the 'My Computer' icon on the Windows desktop. Then click 'Properties', select the 'Hardware' tab and press the 'Device Manager' button as in Fig. 3.7.

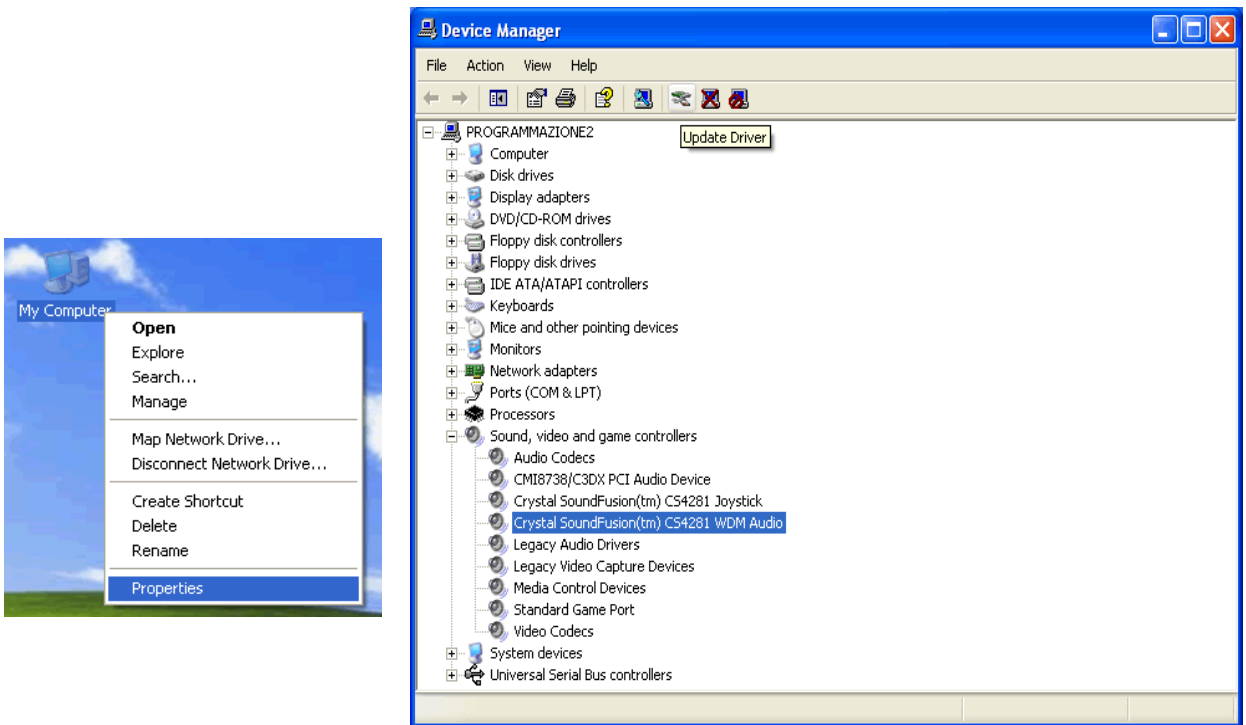


Figure 3.7

XP installed a driver for the Crystal hardware accelerator that the CLIO PB4281 card is using. Press the 'Update Driver' button and enter the 'Hardware Update Wizard' (Fig. 3.8).

Select 'Install from a list or specific location (Advanced)' and click 'Next'; then select 'Don't search. I will choose the driver to install' and click 'Next' again.

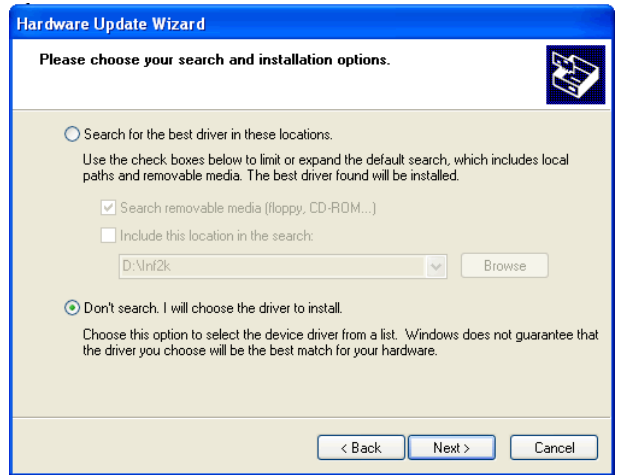
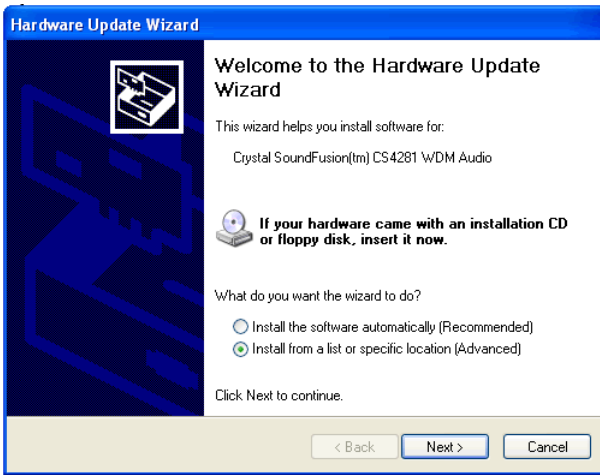


Figure 3.8

Insert the CLIO CD-ROM, press 'Have Disk' and choose the CLIO2K.INF file inside the \INF2K directory of the CD-ROM (see Fig. 3.9).

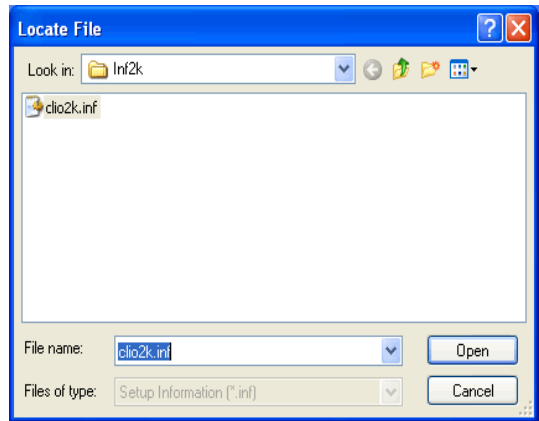
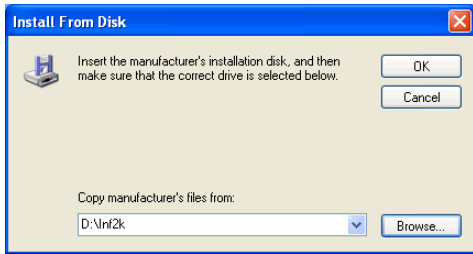


Figure 3.9

Ignore the message 'This driver is not digitally signed!', press 'Next'; **ignore** the subsequent message about Windows Logo testing, press 'Continue Anyway' (Fig. 3.10).

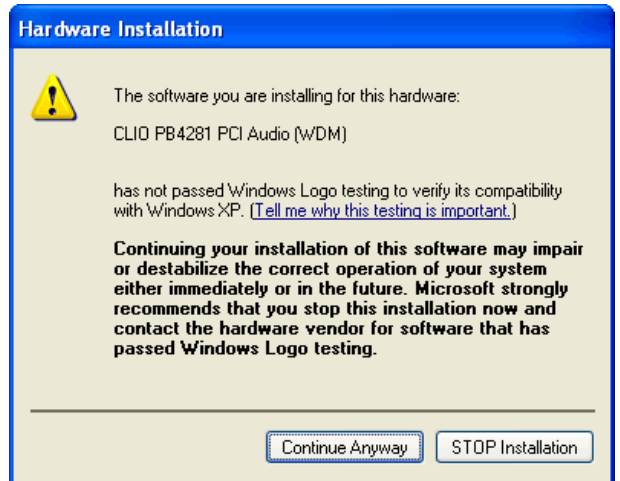
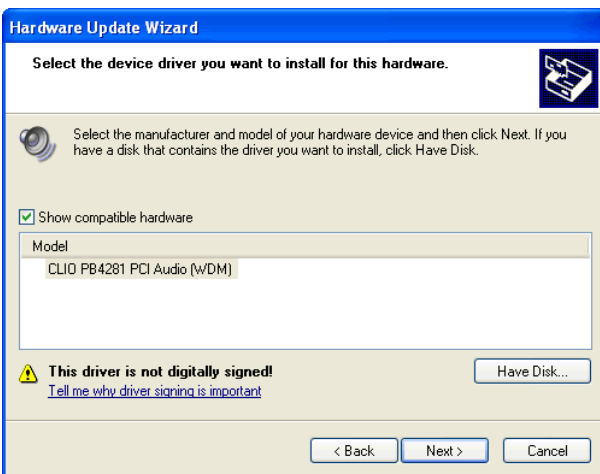


Figure 3.10

You should be prompted by the following success message.

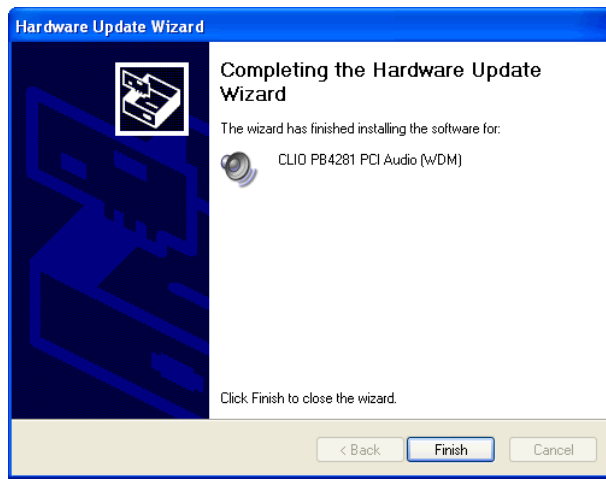


Figure 3.11

Let's now verify that the hardware installation and registration is OK.

Click with the **right** mouse button on the 'My Computer' icon on the Windows desktop. Then click 'Properties', select the 'Hardware' tab and press the 'Device Manager' button as in Fig. 3.12.

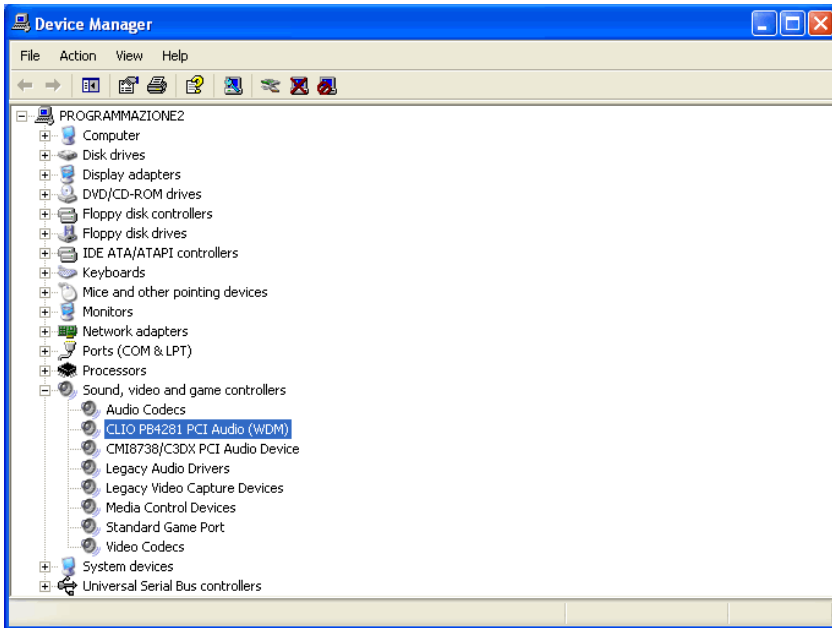


Figure 3.12

The presence of the 'CLIO PB4281 PCI Audio (WDM)' under 'Sound, video and game controllers' (in place of the previously installed Crystal driver) confirms the correct installation.

3.3.3 CONNECTING THE SC-02 UNIT & USB DRIVERS INSTALLATION

To connect the SC-02 Signal conditioner to your PC you need the following cables:

- 1) 2 x Stereo mini jack to two RCA plugs (red plus white) audio cable.
- 2) 1 x USB cable.



Figure 3.13

First connect the SC-02 Signal Conditioner to the PB4281 card:

- 1) Connect one audio cable from the card 'Line Out' plug to the two RCA plugs on the rear panel of SC-02 labeled 'FROM PC'; red plug channel B, white plug channel A.
- 2) Connect one audio cable from the card 'Line In' plug to the two RCA plugs on the rear panel of SC-02 labeled 'TO PC'; red plug channel B, white plug channel A.

The figure shows the audio and dc connections as they should be used.



Figure 3.14

Now connect the USB cable from the SC-02 to one free USB port of your computer.

Be ready to install USB drivers!



Figure 3.15

You will be prompted with the dialog boxes in Fig.3.16. Select 'No. Not this time' and then select 'Install from a list or specific location (Advanced)'.

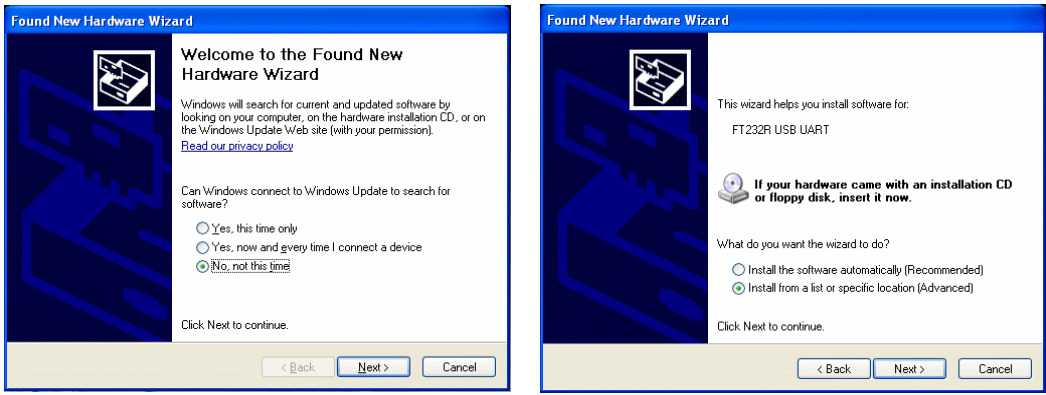


Figure 3.16

At the successive prompt Select 'Search for the best driver in these locations' and press the 'Browse...' button. Choose the 'USB Drivers' folder inside CD-ROM (see Fig.3.17). It will be installed the **USB Serial Converter**.

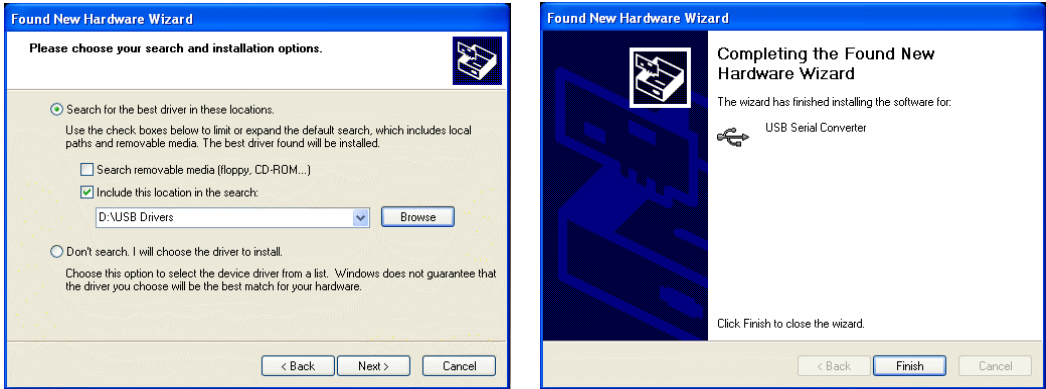


Figure 3.17

You will be prompted again to install the second USB device: repeat the same procedure to install the **USB Serial Port** (Fig.3.18).

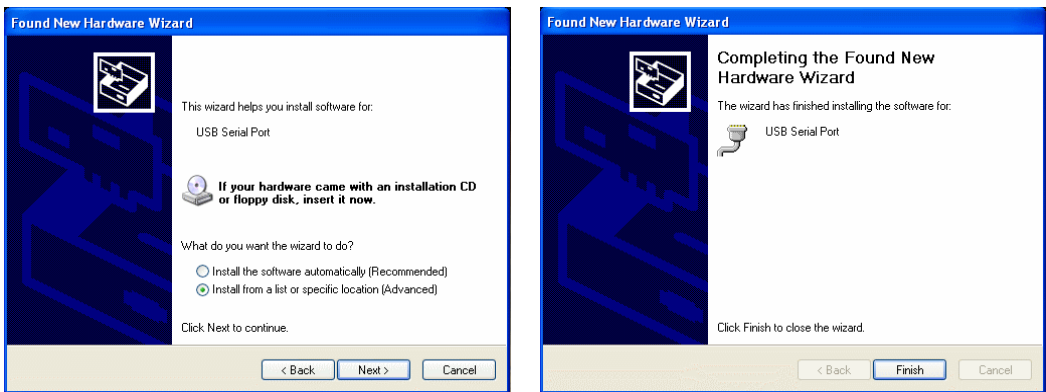
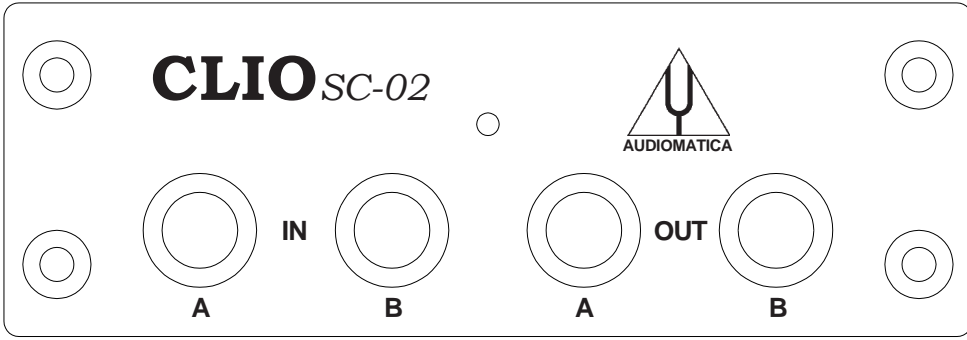


Figure 3.18

Windows drivers installation is now finished and your CLIO system ready to be used. The last step is software installation covered in 3.4.

The connections between the PB4281, SC-02 and your PC **shouldn't normally be changed**; in every day work you will always use the SC-02 front panel connectors.



3.3.4 IMPORTANT ADVICE

If your computer has another sound card fitted in addition to the CLIO Card ensure that this card and NOT the CLIO Card is chosen as the preferred card. This will ensure that all system sounds will be played by the other device. Open the audio properties under the Control Panel and select the second card as the preferred. The example in Fig. 3.23 refers to a VIA audio device under Windows XP Professional (refer also to Fig.3.15 for a device map of the same PC).

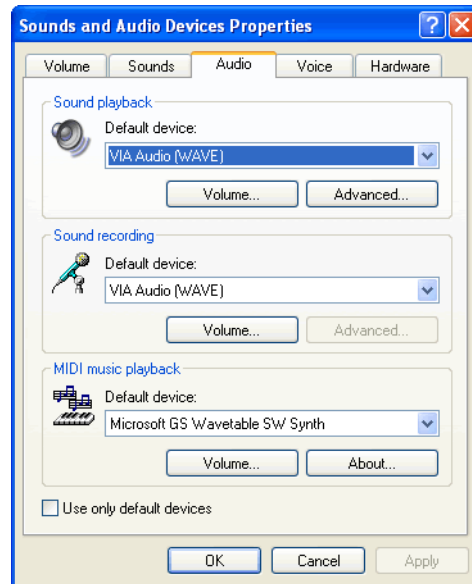


Figure 3.23

3.4 SOFTWARE INSTALLATION

This paragraph deals with **software installation**.

The CLIO software is provided either on its own CD-ROM or, in electronic format, as a single, self-extracting, executable file.

Figure 3.24

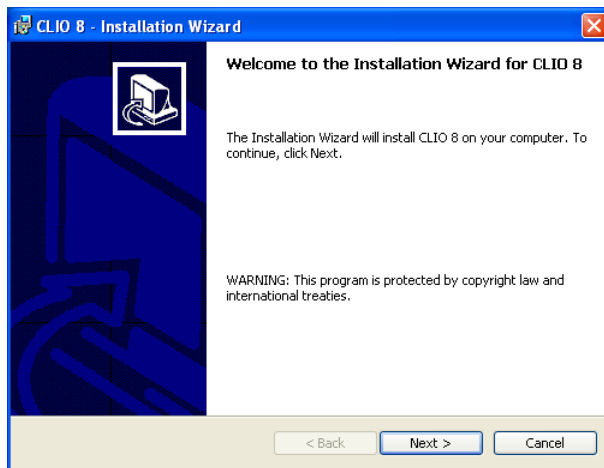


In the first case the CD-ROM root will contain a file named **setup.exe** while in the second the file will be named with your system's serial number (**win8_1019070024.exe** as in Fig. 3.24); click on these files to start the software installation (Fig.3.25).

While installing be sure to have administrative rights.

The procedure is completely automatic and will only request you to accept the Software End User's License Agreement and input some information in order to correctly install CLIO; the software installer will also check your operating system version and, in certain cases, will request you to restart Windows in order to finalize the installation.

Figure 3.25



After successfully completing this procedure take note of the installation directory of CLIO (usually C:\Program Files\Audiomatica\CLIO 8).

3.5 THE 'CLIO BOX'

A few words about the SC-02 Signal Conditioner.



Figure 3.26

This unit is needed to correctly interface analog signals to the PB-4281 PC card; it is also important as it has an internal reference used to calibrate the system and also stores the system's serial number inside its internal EEPROM; Fig.3.27 shows how to find your CLIO system serial number and SC-02 firmware release (after you have removed the upper cover).

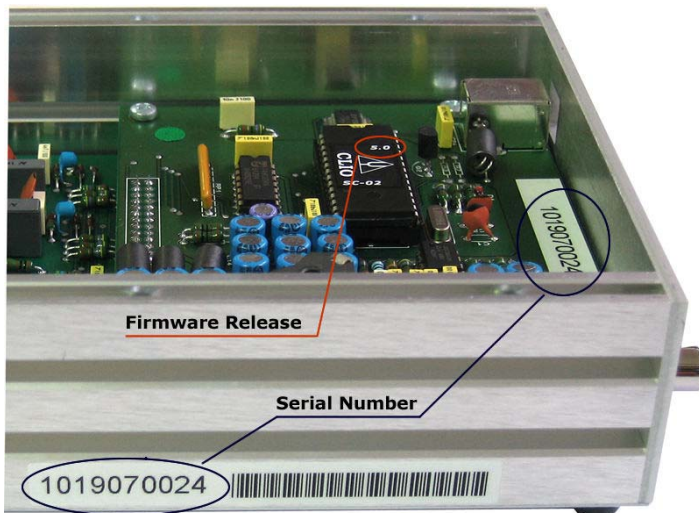


Figure 3.27

The serial number is very important and should be mentioned each time you get in contact with Audiomatica, either for technical support or for software upgrade.

When using your CLIO system you will normally use the SC-02 front connectors; the connections between the SC-02 and the PB-4281 card are normally left untouched. As you'll become extremely familiar with this hardware unit we are going to give it a nickname: from now on we will call it **'the CLIO Box'**. Also the CLIO software refers to it with this nickname.

3.6 RUNNING CLIO FOR THE FIRST TIME

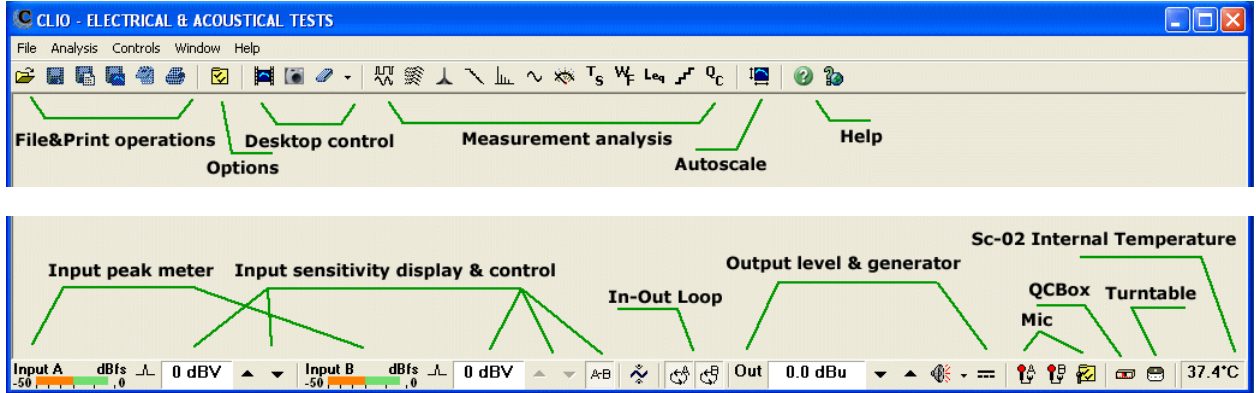
If you have completed the preceding installation procedure, you are ready to run CLIO!

The following steps will guide you through a complete verification of the system performance and operation.

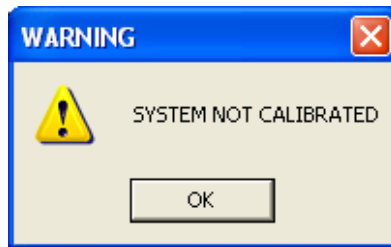
From the **Start Menu** choose **Programs**, then **CLIO 8** and click on the CLIO icon.



The program should start smoothly and present the main desktop.




If the the system is not calibrated, as the first time you run it, you will receive the following message.




Should CLIO display an error message take note of it and go to the troubleshooting section (3.9).

3.6.1 INITIAL TEST

Let's now execute our first test measurement - play and capture a 1kHz sinusoid.

First of all click on the In-Out Loop  button for channel A; in this way the CLIO Box connects output A with input A with an internal relay. This connection is very important as it lets you capture and analyze a signal generated by CLIO without the need for an external connecting cable.

Then click on the generator icon  to play the 1kHz sinusoid (1031.25Hz to be exact; more on this later, it's the default signal). Then press the **F4** keystroke to invoke the Multi-Meter as in Fig.3.28.

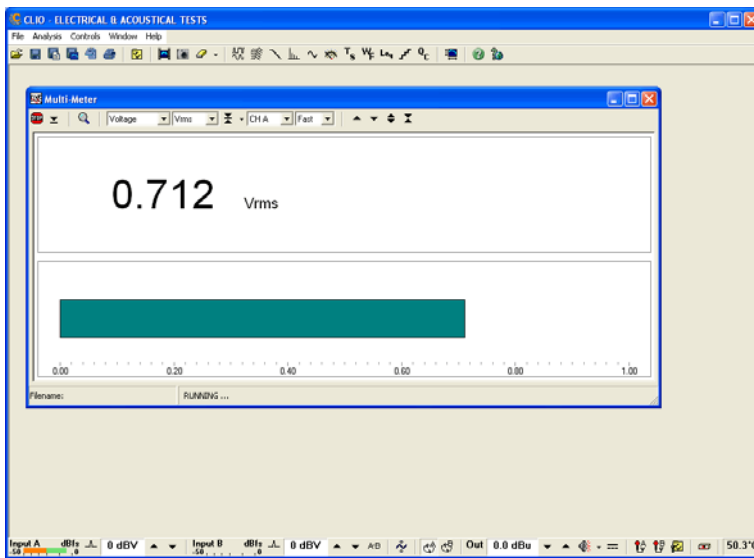


Figure 3.28

If everything is OK you should obtain a reading of circa 0.7V, variable between a minimum of 0.6V and a maximum of 0.9V, which is the mean output level of a sinusoidal signal when the system is not calibrated.

To conclude your initial test, execute the calibration procedure described in the following section.

Repeating the test described after the system has been calibrated you should get the reading of 0.77V (-2.2dBV) which is the calibrated output level of a sinusoidal signal.

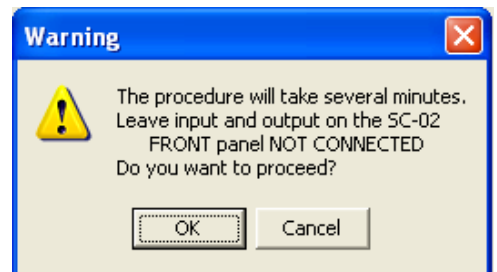
3.7 SYSTEM CALIBRATION

This section describes how to perform the system calibration.

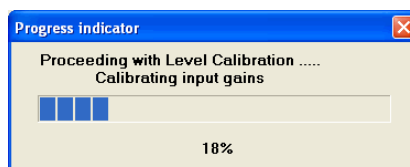
Be sure that, any time you perform a calibration, the system has warmed up for, at least 15-20 minutes.

Select **Calibration** from the **File** menu (5.6);

Leave the CLIO Box front plugs unconnected.



Answer **OK** to the initial prompt; this will run an automatic procedure that will last several minutes. The calibration procedure is completely automatic and several progress indicators will accompany all the executed measurements. At the end of it your CLIO system should be calibrated and ready to carry out measurements.



At the end of the calibration process it is always mandatory to verify the calibration itself; this is done by two simple measurements as described in the following section.

3.7.1 CALIBRATION VALIDATION

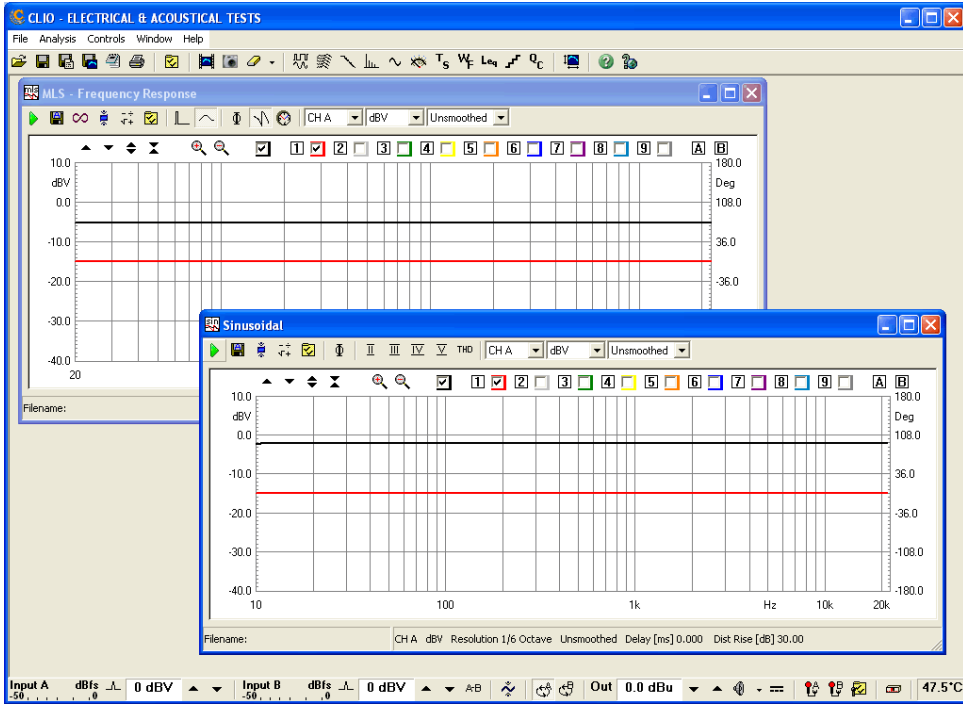








Figure 3.29

To verify the calibration first check that the generator output level is set to 0dBu (refer to 5.4.3 for details).

Press the channel A In-Out Loop button .

Then click on the MLS button  to invoke the MLS control panel. Press the Go  button to execute an MLS frequency response measurement; after about **1 second** you should obtain the desired result, a straight line (black) as in Fig.3.29. You can click on the graph and inspect the amplitude of the measured signal: you should obtain a reading around -5.2dBV, this is the correct output level of the MLS signal with the generator output set to 0dBu.

Now click on the Sinusoidal button  to invoke the Sinusoidal control panel as in Fig.3.29. Press the Go  button to execute a Sinusoidal frequency response measurement; after about **5 seconds** you should obtain the desired result, again a straight line (black) as in Fig.3.29. You can click on the graph and inspect the amplitude of the measured signal: you should obtain a reading around -2.2dBV, this is the correct output level of the sinusoidal signal with the generator output set to 0dBu.

To ensure a 100% correct calibration you also need to inspect the phase responses of both measurements. To do this press the phase button  and verify that you obtain a straight line (red curves in Fig.3.29) the readings in this case should be around zero degrees in both cases.

As a final test repeat the 1kHz tone test described in 3.5.1. The expected result is shown in Fig.3.30.

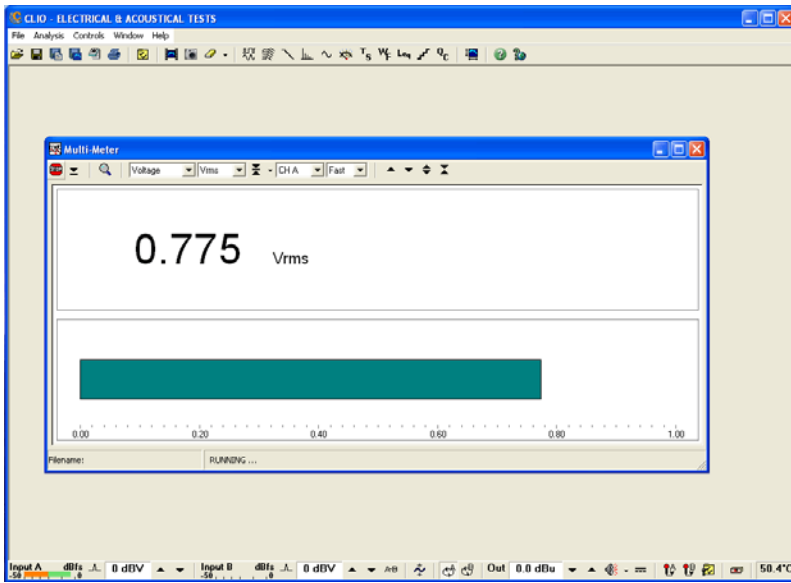


Figure 3.30

3.8 CLIO SERIAL NUMBER AND DEMO MODE

Each CLIO system has its own **serial number** which plays an important role since the CLIO software is hardware protected and relies on a correct serialization in order to run.

Refer to 3.5 to identify your system's serial number.

If the CLIO software doesn't find a CLIO Box with a correct serial number it gives a warning message and enters what is called **DEMO mode**; in this way it is possible to run CLIO in a PC where the CLIO hardware is not installed while still allowing you to perform post-processing and other off line jobs.

3.9 TROUBLESHOOTING CLIO INSTALLATION

To receive assistance please contact Audiomatica at info@audiomatica.com or connect to our website www.audiomatica.com.

4 CLIO BASICS

4.1 INTRODUCTION

This chapter gives you the basic information about CLIO and the related hardware and how to connect and operate it, while the following chapters explain in more detail the individual measurements available to users of CLIO. Chapter 5 deals with other general functionality of CLIO.

Here you will find information about:

- **Help**
- **Main desktop, toolbars and menu**
- **Shortcuts**
- **Generator, Input and Output, Microphone**
- **Amplifier & SwitchBox, Turntable**
- **Connections**

4.2 GETTING HELP

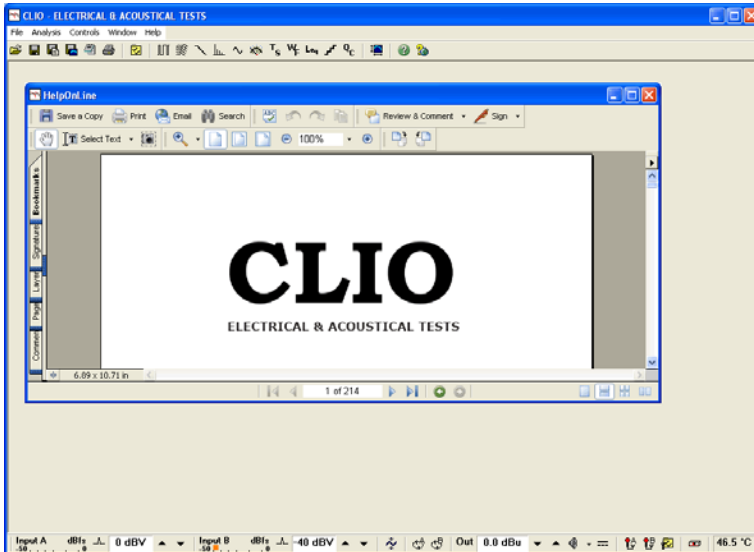


Figure 4.1 CLIO Help On-Line

To request the CLIO on-line help press F1. The on-line help screen (Fig. 4.1) should appear and the context-sensitive search should locate the page appropriate to the currently active menu, dialog or control.

*Note: in order for the CLIO help to work you should have **Adobe Acrobat Reader** installed on your system. The CLIO CD-ROM contains a correct version of this utility. Refer to Adobe (www.adobe.com) for any further information.*

The CLIO help can be invoked also from outside CLIO; to do this go to the Start Menu, then Programs, then CLIO and then click on 'CLIO Help'; in this way Acrobat will let you read and print this User Manual.

If you are not familiar with Acrobat, please spend some time to familiarize yourself with its capabilities, controls and navigation buttons.

Another way to obtain help is through the Help Menu (see 4.6.5) which gives you the possibility to view the on-line resources available in the Audiomatica and CLIO websites.

4.3 CLIO DESKTOP

The CLIO desktop presents itself as in Fig. 4.2 and gives you access to the **main menu**, the (upper) **main toolbar** and the (lower) **hardware controls toolbar**.

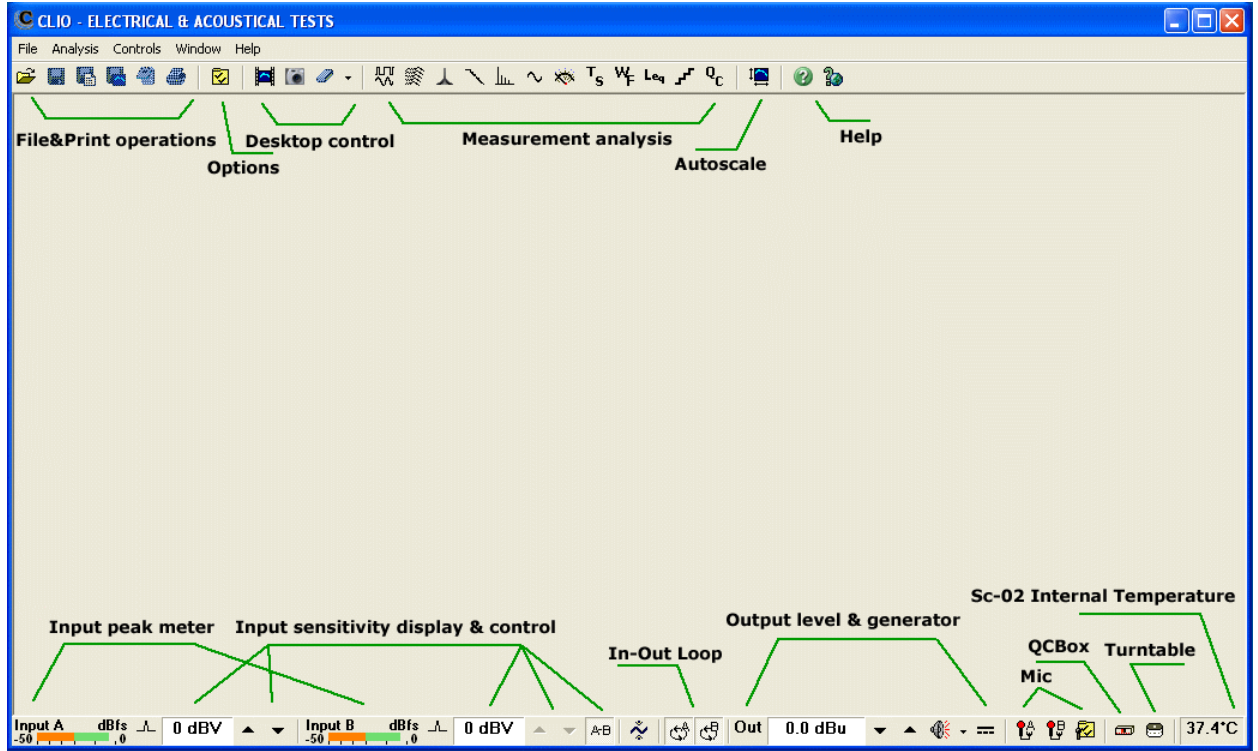


Figure 4.2 CLIO Desktop

Inside the main toolbar and the hardware controls toolbar you can locate several distinct functional areas as shown in the above figure. There now follows a description of all the controls inside the two toolbars. Refer to Section 4.6 for a detailed view inside the main menu.

4.4 MAIN TOOLBAR

Please refer to Chapter 5 for information about **File and Print functions**, **Options** and **Desktop control**.

4.4.1 MEASUREMENT ANALYSIS

By clicking on these toolbar buttons it is possible to interact and display each measurement control panel. Once the toolbar button is clicked the appropriate panel will be opened or reactivated. Any currently active panel will automatically be deactivated on activation of the new one.

The same functionality will be obtained with the relative **shortcuts** or by making a selection inside the Analysis Menu (see 4.6.2); a third way is to select a window through the Windows Menu (see 4.6.4).

 Enters the MLS&LogChirp Analysis control panel.


 Enters the Waterfall&Directivity control panel.


 Enters the Wavelet Analysis control panel.

 Enters the Acoustical Parameters control panel.

 Enters the FFT&RTA Analysis control panel.

 Enters the Sinusoidal Analysis control panel.

 Enters the Multimeter control panel.

 Enters the Thiele&Small Parameters control panel.


 Enters the Wow&Flutter control panel.

 Enters the Leq control panel.

 Enters the Linearity&Distortion control panel.

 Enters the Quality Control Processor.

4.4.2 AUTOSCALE

 Enables autoscale. When autoscale is active the software, during measurements, determines the optimum Y-scale settings.

4.4.3 HELP

 Invokes the Help control panel.

 Invokes the Internet On-Line Help.

4.5 HARDWARE CONTROLS TOOLBAR

4.5.1 INPUT CONTROL

 **channel A input peak meter**

Constantly monitors channel A input signal level vs. full digital input scale.

 Controls channel A input polarity.

channel A input sensitivity display & control buttons

Displays the actual input sensitivity (in dBV) of the instrument, i.e. the voltage level beyond which the hardware saturates. It is possible to modify it in 10dB steps by pressing the ▼ (F9) and/or ▲ (F10) buttons.

 **channel B input peak meter**


Constantly monitors channel B input signal level vs. full digital input scale.

 Controls channel B input polarity.

channel B input sensitivity display & control buttons


Displays the actual input sensitivity (in dBV) of the instrument, i.e. the voltage level beyond which the hardware saturates. It is possible to modify it in 10dB steps by pressing the ▼ (SHIFT+F9) and/or ▲ (SHIFT+F10) buttons.


 Links input channels full scale level controls. If this button is pressed the two channel sensitivities are set equal and channel A controls act also on channel B.

 Selects the Autorange mode. When in autorange mode the input sensitivity is automatically adjusted by the instrument to achieve the optimum signal to noise ratio.

4.5.2 INPUT/OUTPUT LOOPBACK

The CLIO Box features an internal loopback which is very useful for performing self tests.

 Connects channel A output to channel A input with an internal relay.

 Connects channel B output to channel B input with an internal relay.

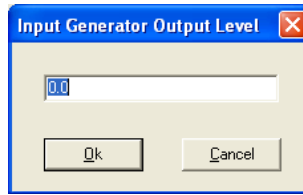
4.5.3 GENERATOR CONTROL

CLIO's generator can be controlled from the dedicated toolbar buttons and dialogs; for a reference about the possible kind of signal you may generate please see chapter 7.

output level display & control buttons

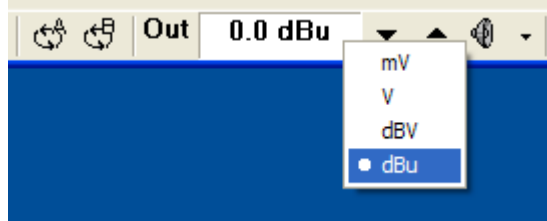
Displays the actual output level (usually in dBu) of the internal generator. This level is valid for both output channels. It is possible to modify it in **1dB steps** pressing the ▼ (F7) and ▲ or (F8) buttons. If the **Shift** key is pressed simultaneously then the steps are of **0.1dB** increments.

It is also possible to input a numeric value directly with the following dialog which pops up when you **click** on the output level display.



In this case (manual input) the output level will be approximated with a **0.01dB** precision.

If you **right-click** on the output level display you invoke the out units pop up from which it is possible to select the output level unit among dBu, dBV, V and mV.



 Switches on and off the generator.

Use the **ESC** key to immediately **kill** the generator .

If you wish to receive a confirmation message (Fig. 4.3) before playing the generator or applying DC voltage, then check the appropriate box in the **General Options** dialog (5.4).



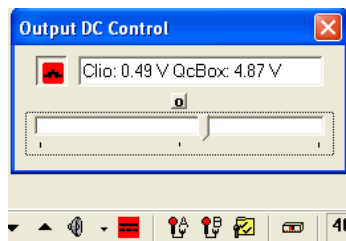
Figure 4.3

generator drop down menu

Clicking on the small arrow beside the generator button will invoke the generator drop down menu, from there it is possible to choose the output signal type to be generated. The default signal at startup is a 1031.25Hz sinusoid.



Refer to Chapter 7 Signal Generator for a detailed description of all generated signals.

 Opens the **output DC voltage** control panel.





With this control panel it is possible to manage the DC voltage that the SC-01 signal conditioner is capable of superimposing on the signal generated by channel A output. This DC voltage ranges from **-2.5V to +2.5V** (at SC-01 channel A output) which you may set with the slider.

Note: if you feed channel A output to a DC coupled amplifier (like the CLIOQC Amplifier & Switchbox) the DC voltage that you will see at the amplifier's output will be multiplied by its gain. This is why the control panel also displays the calculated DC voltage present at the QCBox output; the calculation takes into account the QCBox type selected in the External Hardware control (see 4.5.1). For example the DC voltage that may be present at the output of the QCBox Model 4 ranges from **-25V to +25V**.

With the Set DC  button it is possible to activate the desired DC. When DC is active the control panel button becomes red  to signal this particular state as in the figure below. The small Zero DC button lets you immediately reset the output DC to 0V. **Pay great attention when driving loudspeakers with signals with DC present.**

4.5.4 MICROPHONE CONTROL

 Switches Channel A phantom power on and off. This 8.2V supply is needed to operate Audiomatica's microphones MIC-01 and MIC-02.

 Switches Channel B phantom power on and off.

 Enters the Microphone Sensitivity dialog box.

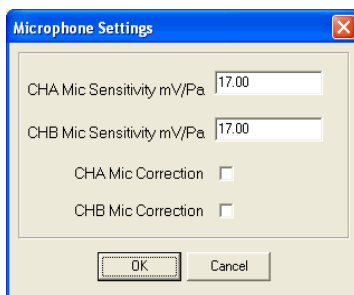


Fig.4.5 Microphone sensitivity dialog

When taking acoustical measurements, the readings and the scales will be in Pascals (Pa or dB SPL). In this case, the software will assume that you are measuring a pressure quantity and it therefore needs to know a conversion factor that defines the voltage produced by the microphone when it is measuring a certain pressure. This conversion factor is usually the sensitivity of the microphone (as found in the microphone's calibration chart) or the sensitivity of the microphone + preamplifier chain of equipment. When working with the CLIO system there are two possible cases:

- you are using the microphone MIC-01 or MIC-02, so it is necessary to input the sensitivity of the microphone (in mV/Pa).
- you are using the PRE-01 preamplifier, it is necessary to know its internal gain; if it is 0dB then input the microphone sensitivity, if it is +20dB then input the microphone sensitivity multiplied by 10.

NOTE: It is necessary to input two separate sensitivities, one for channel **A** and one for channel **B**. When the **A-B** balanced input configuration is selected (see 4.7.1) the software will use the channel **A** sensitivity.

Please also refer to 8.4.1 for a description of the procedure for assessing the sensitivity of the microphonic chain using an acoustic calibrator capable of producing 94dB SPL.

4.5.5 CORRECTING THE MICROPHONE RESPONSE

By checking the Microphone Correction check boxes the software will correct the measured curve according to the data stored in two text files named "MICA.CAL" (for input channel A) and "MICB.CAL" (for input channel B).

The microphone correction files, if present, must be placed inside the installation folder (usually c:\program files\audiomatica\clio 8\).

Note: The maximum number of correcting points allowed is 100.

The example below shows a sample text file created to store the microphone frequency response:

Freq	dB	Phase
1000	0	0
4000	0.25	0
8000	0.33	0
10000	0.5	0
15000	1.75	0
20000	2.5	0

Note: microphone correction will affect the measured curve only if dB SPL is selected as Y Scale unit.


If your microphone came with frequency calibration data supplied by Audiomatica (see 2.2.3) you can find the correction file inside the floppy disk.

The file is stored with the name *serialnumber.cal*; for example in the disk given with the microphone with serial 9501255 you will find the "9501255.CAL" file.

To use it you must:

- 1) Copy it inside the CLIO 8 installation folder
- 2) Rename it according to which input channel it is connected; "MICA.CAL" for channel A or "MICB.CAL" for channel B.

4.6 EXTERNAL HARDWARE CONTROL

 Enters the External Hardware Controls dialog box. This dialog box performs controls over some external hardware connected to the computer parallel port. It is possible to choose the parallel port to use and then enter the available control panels.

The following figure illustrates the parallel port bits and how they are used by CLIO.

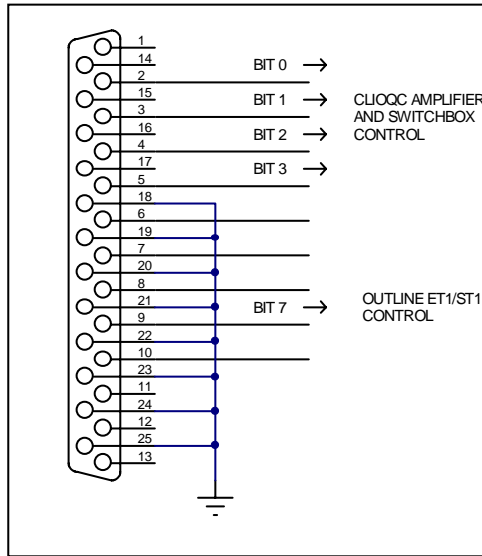


Fig.4.6 Parallel port control signals

4.6.1 CONTROLLING THE CLIOQC AMPLIFIER & SWITCHBOX

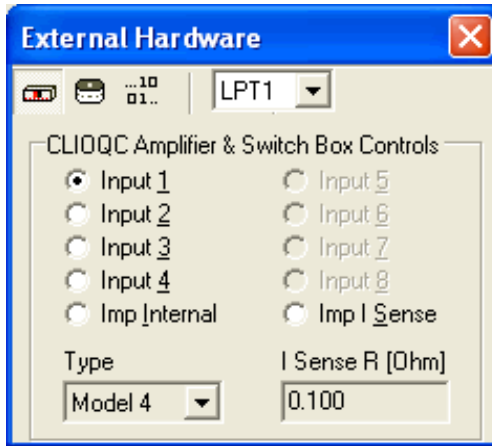


Fig.4.7 CLIOQC Amplifier & Switchbox control panel

This control panel helps you when you are operating the CLIOQC Amplifier & SwitchBox.

You may choose the Amplifier & SwitchBox model and set the value of the internal sensing resistor to obtain maximum precision during impedance measurements (for this please refer to chapter 13).

These controls are self-explanatory; they are also covered in the unit's user's manual, in this manual, and everywhere else the amplifier and switchbox is used.

4.6.2 CONTROLLING A TURNTABLE

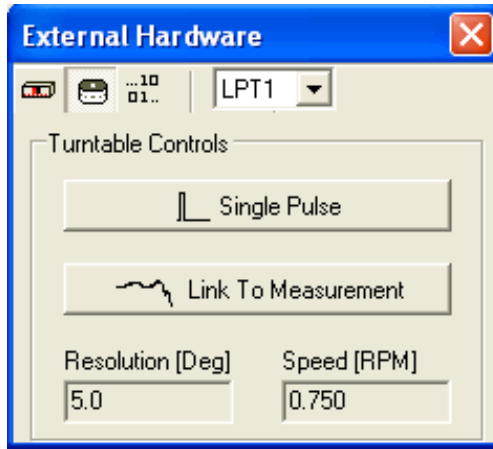


Fig.4.8 Turntable control panel

This control panel helps you when you are operating a turntable; the information given here apply to the control of the **Outline ET/ST Turntable**; they can be adapted to any other device.

The turntable control is achieved with **Bit 7** of the parallel port output bits, as shown in Fig.4.6. The turntable should be connected to the parallel port of the computer by means of a cable defined as follows:

```
PC side DB25 male                ET/ST side DB9 male
Pin 9 <-----> Pin 2
Pin 22 <-----> Pin 4
All other pins unconnected
```

The cable should be connected as in the following figure.

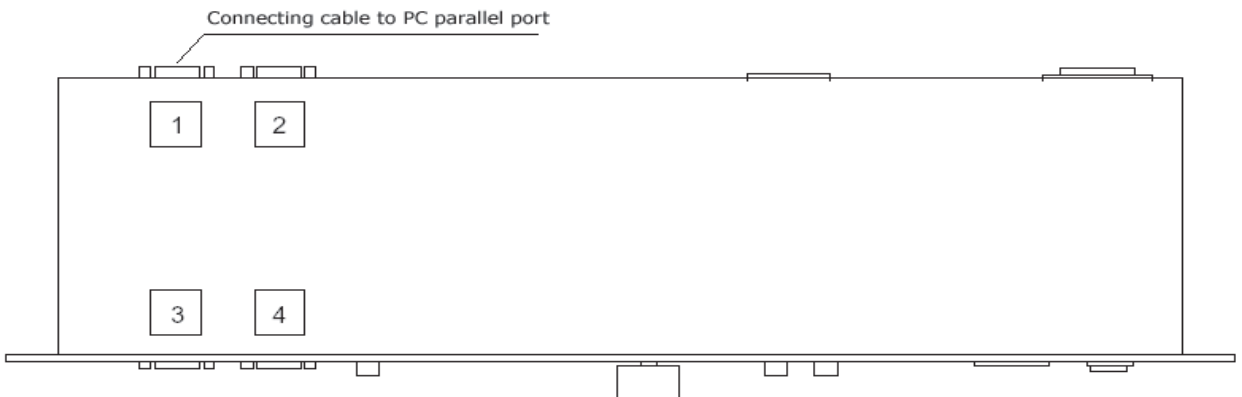


Fig.4.9 Outline ET/ST Turntable connections

Inside the Turntable control panel it is possible to set its **Resolution** (in degrees) and **Speed** (in rotations per minute); the combination of these settings give the software an indication about how much time to wait after the controlling pulse is output.

We have two controlling buttons defined as follows:

Single Pulse It is used to give a single manual triggering pulse to move the turntable to the next position.

Link To Measurement When pressed enables the software to move the turntable at the end of an executed measurement; this works only with the MLS and Sinusoidal control panels. Refer to chapter 12 for an example of how to use this feature during polar measurements.

4.7 MAIN MENU AND SHORTCUTS

The user should carefully read this section which gives you a comprehensive list of all the menu and shortcuts available within CLIO. Shortcuts, i.e. keystrokes that you can press to obtain a certain action, will save you time and increase your productivity.

Also refer to Chapter 6 to learn the measurement interface and its associated shortcuts. Note that the measurement specific (MLS submenu, FFT submenu etc.) menus are active only when the measurement control panel is open and selected.

4.7.1 FILE MENU

Please refer to Chapter 5 for a detailed explanation of the File Menu.

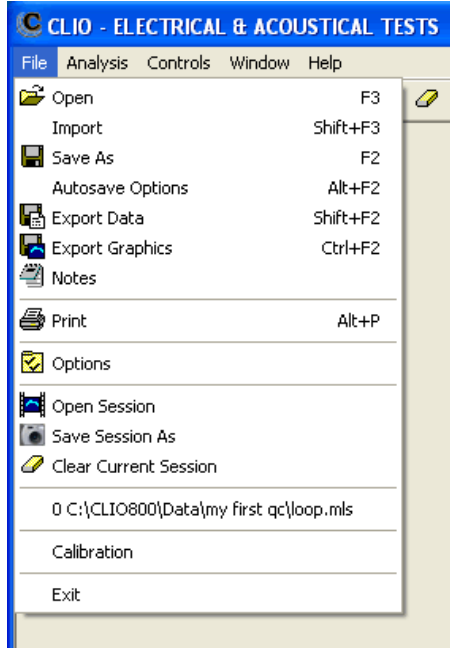


Fig.4.10 File Menu

F3 Saves a measurement file relative to the active control panel.

F2 Loads a measurement file relative to the active control panel.

ALT+F2

Enters the Autosave Settings dialog box (see 5.3.1).

SHIFT+F2

Exports the active measurement as an ASCII file.

CTRL+F2

Exports the active measurement as a Windows Enhanced Metafile, BMP, PNG, JPEG or GIF.

ALT+P

Prints the active measurement.

F6 Enables/disables the AutoScale function (see 4.4.2).

4.7.2 ANALYSIS MENU

The Analysis menu gives you a powerful way to access the measurement menu and menu functions, through the keyboard. Here we present you with all the available menus and shortcuts; the shortcuts, when present, are visible from each submenu and are listed on the right of the function; refer to the specific chapters for each measurement for details about it.

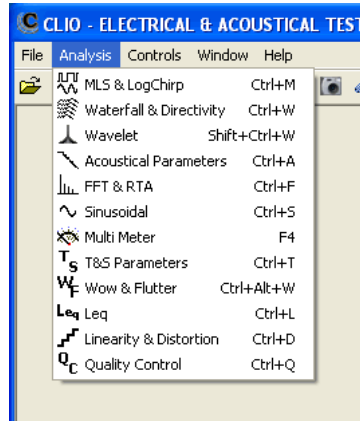


Fig.4.11 Analysis Menu

CTRL+M

Enters the MLS&LogChirp Analysis control panel.

CTRL+W

Enters the Waterfall&Directivity control panel.

SHIFT+CTRL+W

Enters the Wavelet Analysis control panel.

CTRL+A

Enters the Acoustical Parameters control panel.

CTRL+F

Enters the FFT&RTA Analysis control panel.

CTRL+S

Enters the Sinusoidal Analysis control panel.

F4

Enters the Multimeter control panel.

CTRL+T

Enters the Thiele&Small Parameters control panel.

CTRL+Alt+W

Enters the Wow&Flutter control panel.

CTRL+L

Enters the Leq control panel.

CTRL+D

Enters the Linearity&Distortion control panel.

CTRL+Q

Enters the Quality Control Processor.

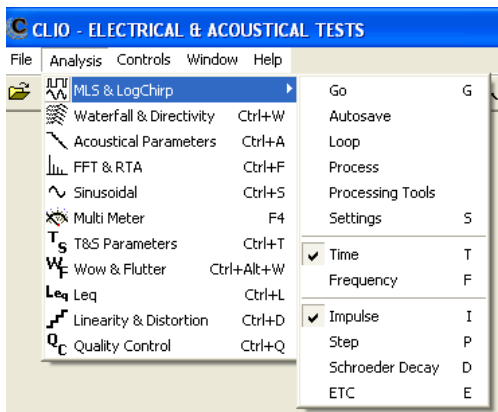
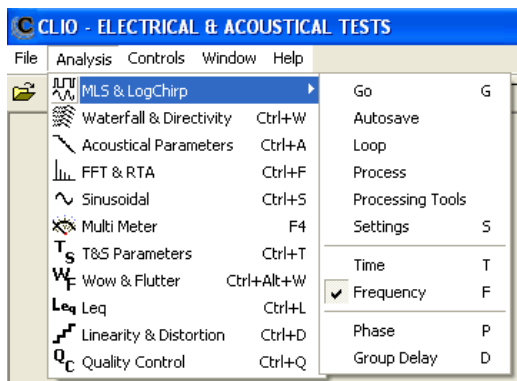


Fig.4.12 MLS&LogChirp Submenu - Frequency and Time

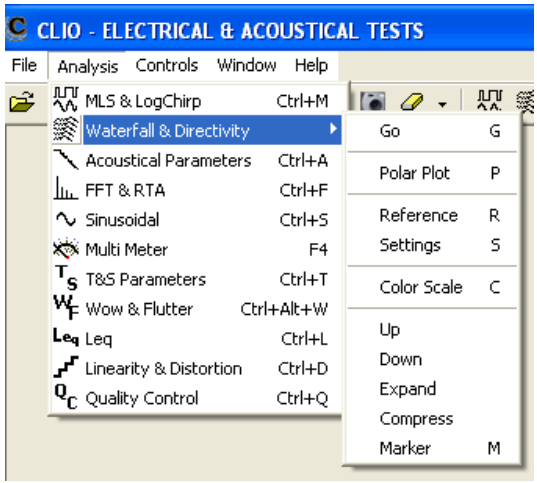
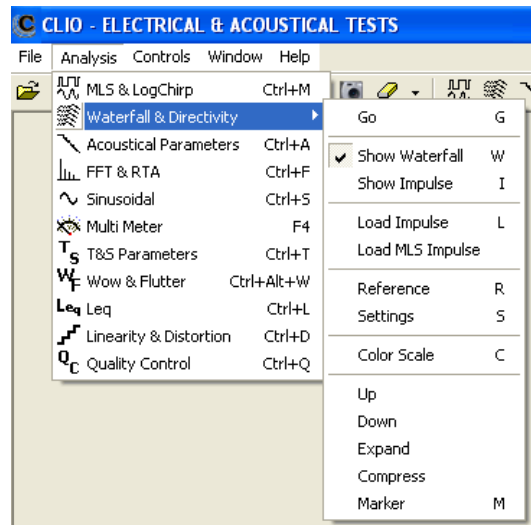


Fig.4.13 Waterfall and Directivity Submenu

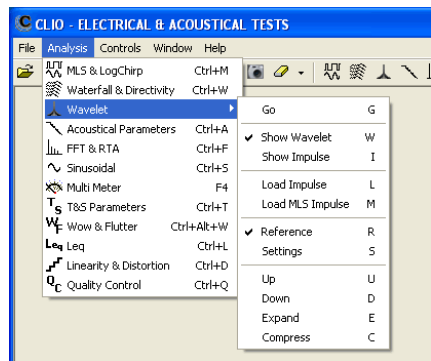


Fig.4.14 Wavelet Analysis SubMenu

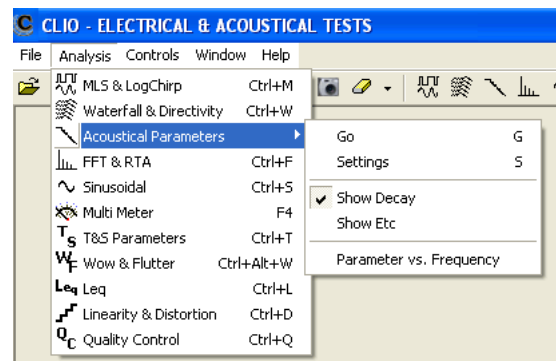


Fig.4.15 Acoustical Parameters SubMenu

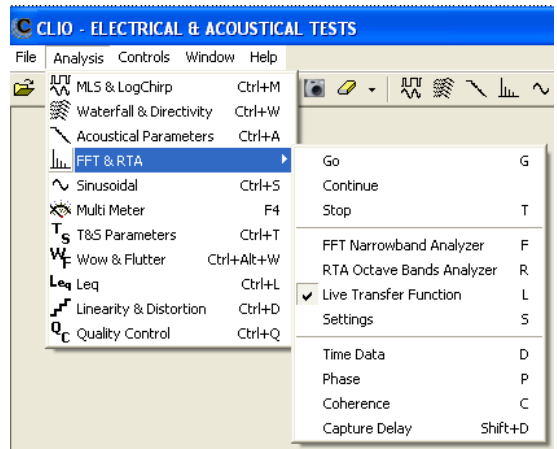
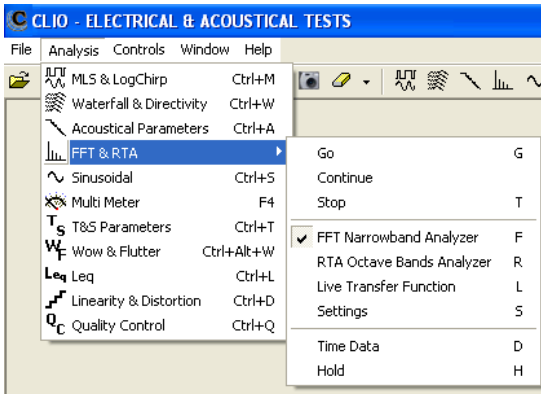


Fig.4.16 FFT and FFT Live SubMenu

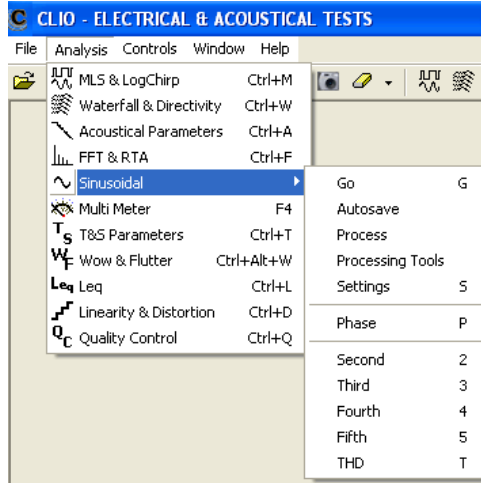


Fig. 4.17 Sinusoidal Submenu

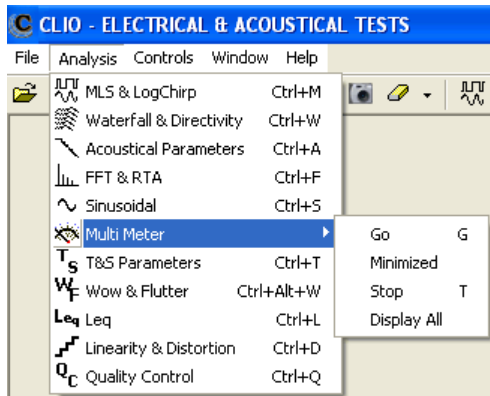


Fig. 4.18 Multi-meter Submenu

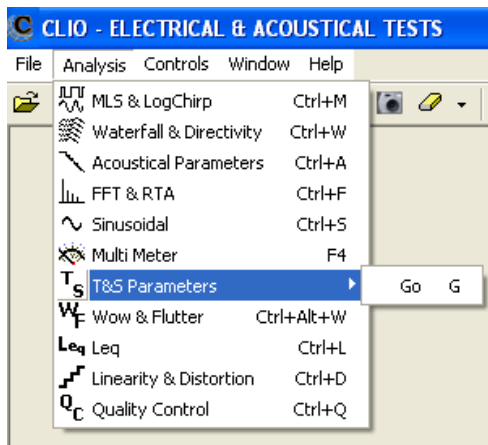


Fig. 4.19 T&S Parameters Submenu

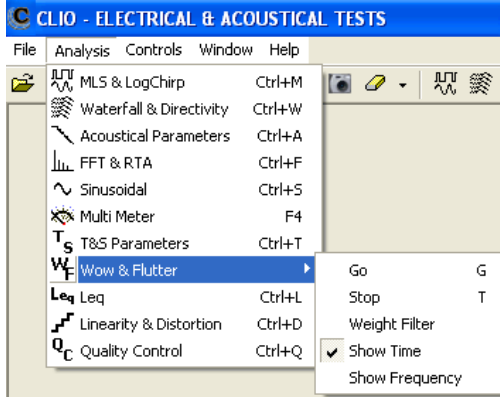


Fig. 4.20 Wow&Flutter Submenu

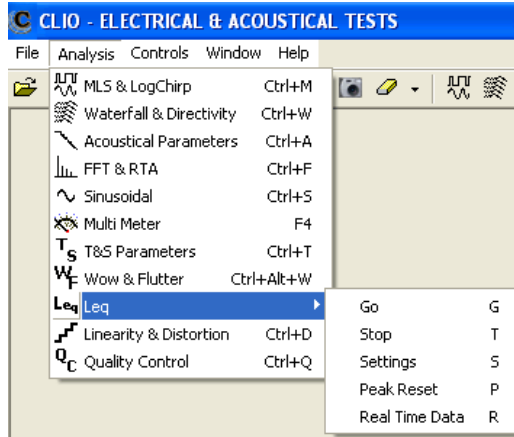


Fig. 4.21 Leq Submenu

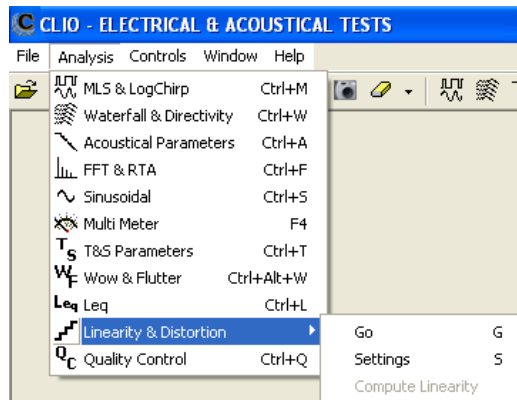


Fig. 4.22 Linearity&Distortion Submenu

4.7.3 CONTROLS MENU

The Controls Menu is the heart of your CLIO hardware; learn how to access hardware control through the keyboard in detail. Refer also to 4.4.2, 4.4.3, 4.4.4 and 4.5.

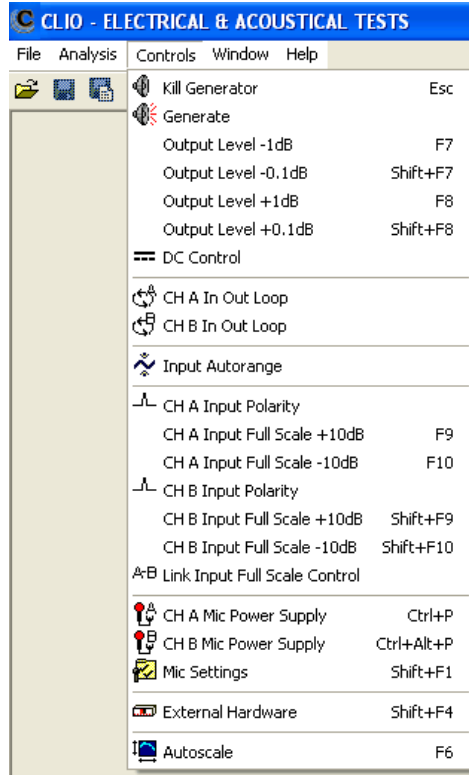



Fig. 4.23 Controls Menu

ESC

Immediately kills the generator. Equivalent to releasing 

F7 Decreases the output level of 1dB. Equivalent to ▼

SHIFT+F7


Decreases the output level of 0.1dB. Equivalent to SHIFT+ ▼

F8 Increases the output level of 1dB. Equivalent to ▲

SHIFT+F8


Increases the output level of 0.1dB. Equivalent to SHIFT+ ▲

F10

Increases channel A input acceptance of 10dB. If the Link Button  is pressed then increases also channel B input acceptance of 10dB. Equivalent to ▲

SHIFT+F10

Increases channel B input acceptance of 10dB. Equivalent to ▲

F9 Decreases channel A input acceptance of 10dB. If the Link Button  is pressed then decreases also channel B input acceptance of 10dB. Equivalent to ▼


SHIFT+F9

Decreases channel B input acceptance of 10dB. Equivalent to ▼

CTRL+P

Switches channel A microphone power supply on and off. Equivalent to 

CTRL+ALT+P


Switches channel B microphone power supply on and off. Equivalent to 

SHIFT+F1

Enters the Mic settings dialog. Equivalent to 

SHIFT+F4

Enters the External Hardware control panel. Equivalent to 

F6 Enables autoscale. Equivalent to 

4.7.4 WINDOWS MENU

The Windows Menu helps you manage all opened windows (i.e. measurement control panels) in a standardized way. You can Tile or Cascade the open windows or access each one directly.

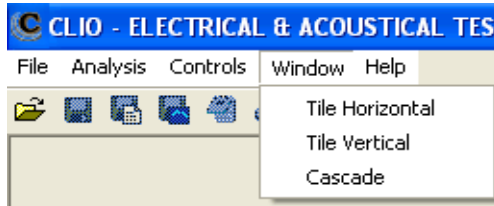


Fig. 4.24 Windows Menu

4.7.5 HELP MENU

From the Help Menu you can access all the available help resources installed in your computer or available directly from Audiomatica over the internet.

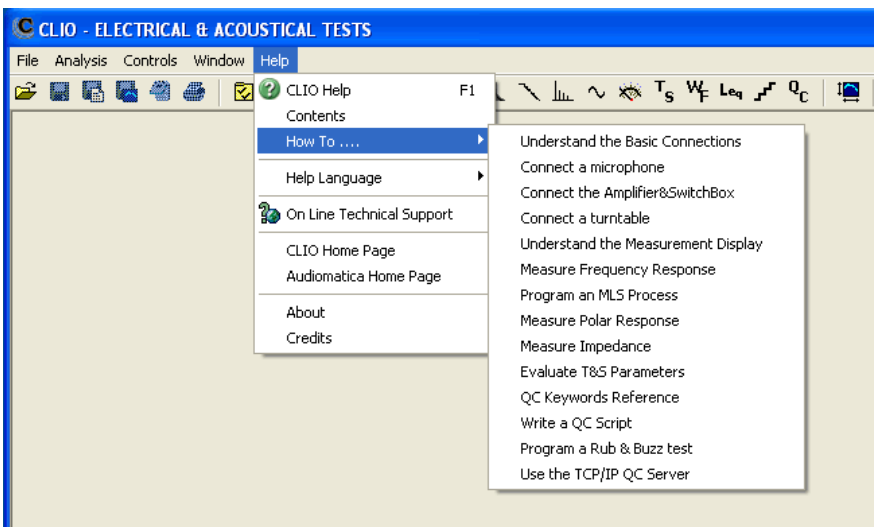


Fig. 4.25 Help Menu

F1 Invokes the On-Line Help.

4.8 BASIC CONNECTIONS

In order to correctly interface CLIO with the outside world you should always keep in mind the following electrical specifications:

MAXIMUM INPUT VOLTAGE:	+40 dBV (283 V peak-to-peak)
MAXIMUM OUTPUT VOLTAGE:	+12 dBu (3.1 VRMS) (sine)
INPUT IMPEDANCE:	64 kOhm
OUTPUT IMPEDANCE:	150 Ohm

4.8.1 CONNECTING THE CLIO BOX

The CLIO Box has four RCA plugs that are used to connect it with the outside world (Fig. 4.26). The left ones are the two input, while the right ones are the output. The system is stereo and can simultaneously process two I/O channels which are named channel **A** and **B**. The output of channel **B** is driven in parallel with channel **A** output.

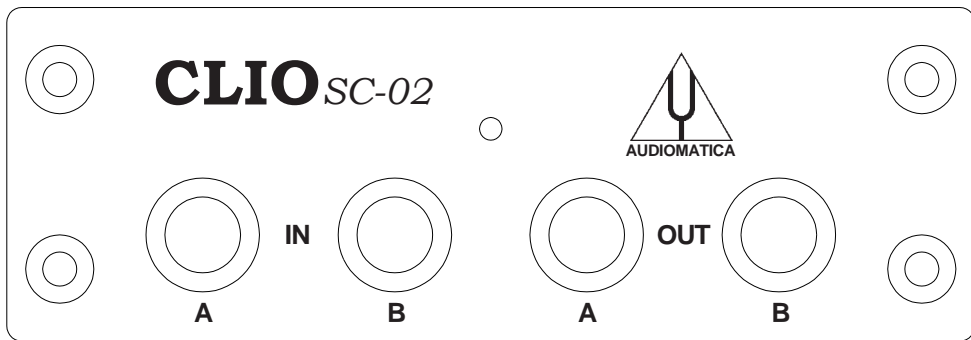


Figure 4.26

The software is able to analyze either the signal present at channel **A** or channel **B** input in an unbalanced configuration or the combined **A-B** signal thus realizing a **balanced** input configuration (Fig. 4.27); in the first case the input connection can be made with one simple RCA cable while in the latter case it is mandatory to use a balanced probe that will connect channel **A** input (used as the positive or "hot") to the first measuring point, channel **B** input (used as the negative or "cold") to the second measuring point and ground.

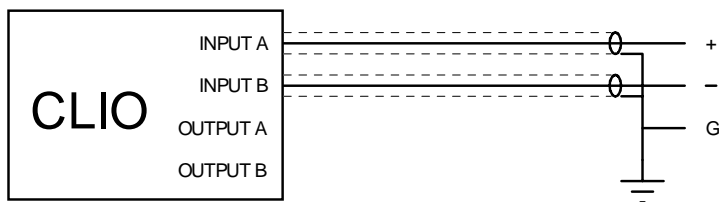



Figure 4.27

WARNING: Both CLIO inputs and outputs are referred to a **common measuring ground**. When you are making measurements in the normal configuration (channel **A** or **B** unbalanced), one of the two measuring points **MUST** be at ground potential! Problems may arise if one tries to use amplifiers with floating outputs; the connection with CLIO could cause damage to such an amplifier. Use the channel **A-B** balanced connection in such cases.

Unless you are carrying out impedance measurements with the **Internal Mode** selected, one of CLIO outputs will usually be connected to an external power amplifier that will drive the loudspeaker, electronic apparatus, or other system under test. The output of the system under test will be connected to one of the CLIO inputs.


4.8.2 CONNECTING A MICROPHONE

For acoustical measurements, the microphone (optionally followed by a preamplifier or power supply) requires to be connected to CLIO's input channel.

When using a MIC-01 or MIC-02 microphone it is possible to connect it **directly** to CLIO's input; remember, in this case, to switch the phantom voltage on by pressing the phantom button . It is good practice to wait a few seconds before taking measurements as the microphone's output stabilizes.

If the measuring point is far from the PC, always lengthen the connection between the preamplifier and CLIO. Make sure that you never use microphone cable that is longer than the one that has been supplied.

In Fig. 4.28 we see the typical test setup for performing acoustical measurements of a loudspeaker. Please **note** that in this schematic diagram, which is drawn in the assumption of using one Audiomatica microphone MIC-01 or 02 directly connected to CLIO input; the output of the power amplifier is connected to the loudspeaker with an inversion in the cables polarity; this compensates the fact that **MIC-01 and MIC-02 microphones are phase inverting** (as are the vast majority of measuring microphones found in the market); when making polarity measurements always treat the measuring chain in this respect considering that the CLIO hardware itself is NON-INVERTING and that all calibrations are usually made under this assumption: any external device like amplifiers, microphones, accelerometers, preamplifiers etc. has to be carefully checked.

It is possible to achieve the same result, via software, simply clicking on the **input polarity button**  in the hardware controls toolbar.

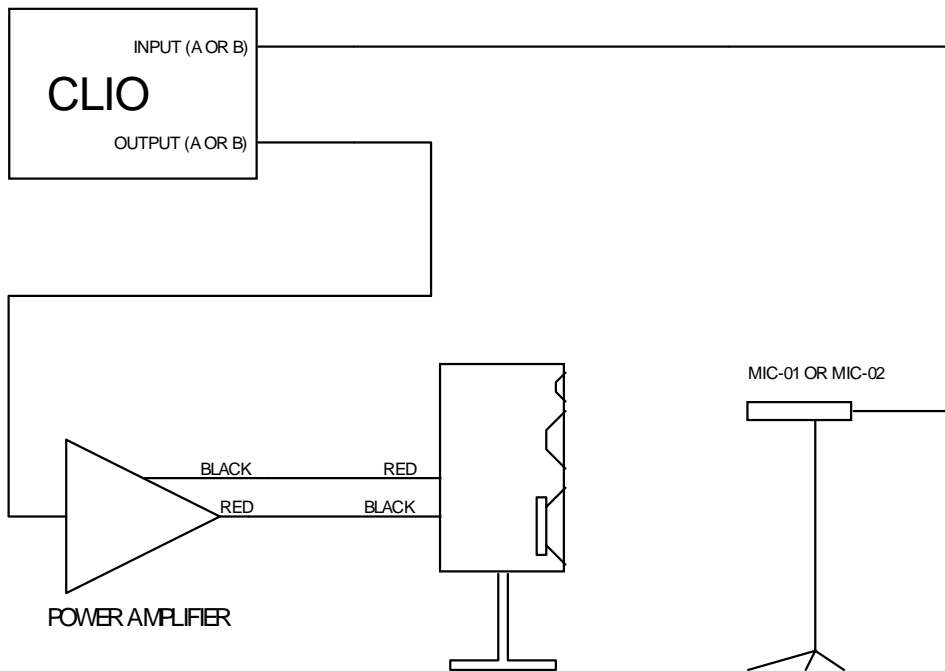


Figure 4.28

4.8.3 CONNECTING THE CLIOQC AMPLIFIER & SWITCHBOX

Fig.4.29 and Fig.4.30 show the connections of a CLIOQC Amplifier & SwitchBox to CLIO.

In Fig.4.29 the unit has its internal switcher set for response measurements.

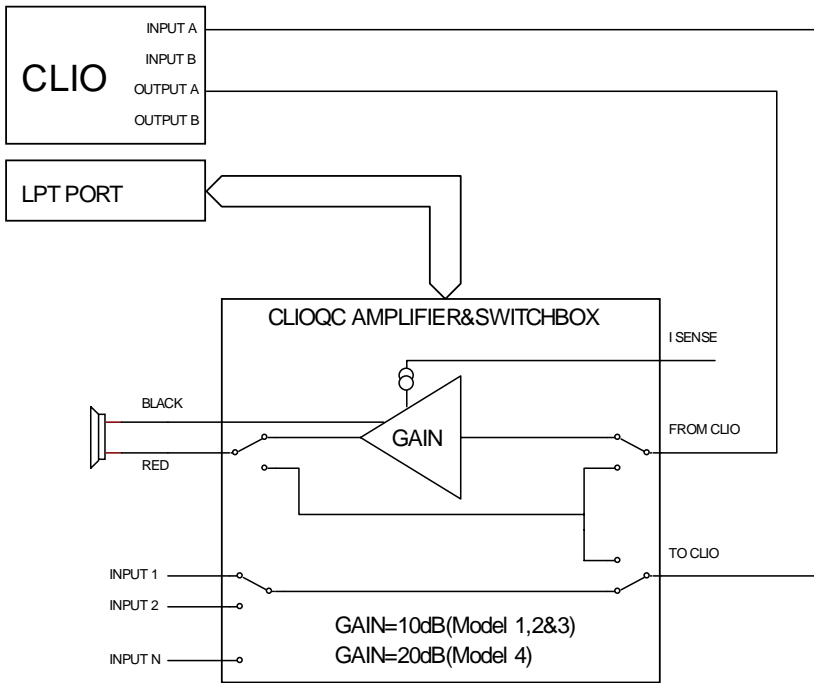


Figure 4.29

In Fig.4.30 the unit has its internal switcher set for impedance measurements (using Internal Mode; refer to Chapter 13 for details).

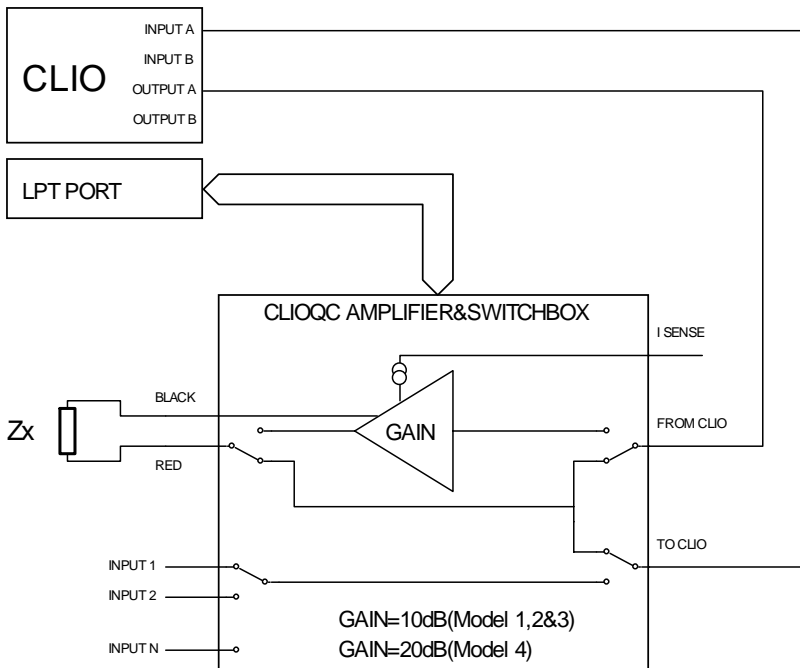


Figure 4.30

5 SYSTEM OPERATIONS AND SETTINGS

5.1 INTRODUCTION

This chapter completes the introduction to CLIO started in Chapter 4.

Here you will find information about:

- **Files extensions**
- **File operations**
- **Exporting data**
- **Exporting graphics**
- **Printing**
- **Software option**
- **Desktop control**
- **Calibration of CLIO**
- **Startup options**
- **Measurements settings**

5.2 REGISTERED FILE EXTENSIONS

During its installation CLIO registers several file extensions which will let you easily find a file done during your work. Browsing your hard disk you will then encounter the icons that we are going to describe.



MLS&LogChirp frequency response data files.



MLS&LogChirp impedance data files.



MLS&LogChirp process files.



Waterfall&Directivity data files.



Wavelet data files.



Acoustical Parameters data files.



FFT and RTA data files.



Sinusoidal frequency response data files.



Sinusoidal impedance data files.



Sinusoidal process files.



Multi-meter data files.



T&S parameters data files.



Wow&Flutter data files.



Leq data files.



Linearity&Distortion data files.



Signal files.



Multitone definitions files.



Autosave definitions files.



Desktop snapshot files.



CLIO setup files.

When you find a CLIO data file it is possible to invoke the program simply clicking on the file itself; if CLIO is open it will load the file in the appropriate menu and display it, if it is closed it will be launched then the file opened.

If you click on a **Desktop snapshot file** you will recall a saved work session comprising open menu and data (see 5.5).

It is possible to run only a single instance of CLIO.

5.3 FILE MENU AND MAIN TOOLBAR BUTTONS

Fig. 5.1 shows the File menu and the Export submenu. Refer to 4.5.1 for the shortcuts active.

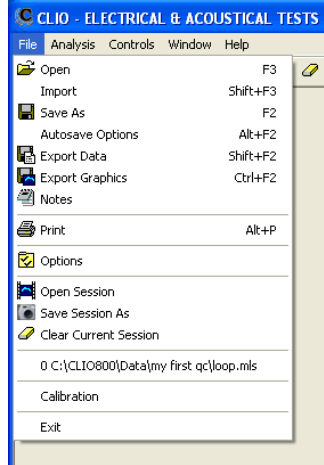



Fig.5.1 File Menu

5.3.1 LOADING AND SAVING FILES

 Loads a measurement file relative to the active control panel. It is important to note that it is possible to load more than one data file type from the following menu:

- **MLS** loads frequency response files (*.mls) and impedance response files (*.mlsi)
- **FFT** loads FFT files (*.fft) and CLIO4 RTA files (*.rta)
- **Sinusoidal** loads frequency response files (*.sin), impedance response files (*.sini), CLIO4 sinusoidal frequency response files (*.frs) and CLIO4 impedance response files (*.imp).

You can select the desired file type from the 'Files of type' drop down inside the Open dialog box.

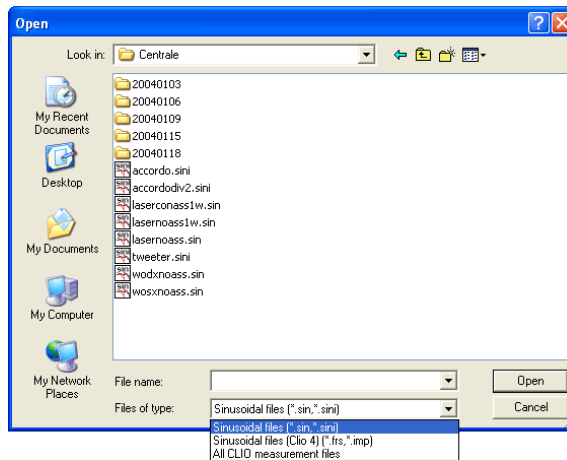




Fig.5.2 Open dialog

 Saves a measurement file relative to the active control panel. It is important to note that the following menu saves more than one data file type:

- **MLS** saves frequency response files (*.mls), impedance response files (*.mlsi) or impulse response as wave files (*.wav)
- **Sinusoidal** saves frequency response files (*.sin) and impedance response files (*.sini)
- **Leq** saves Leq analysis files (*.leq) and captured data wave files (*.wav)

 Invokes the Autosave Settings dialog. It is possible to define the autosaving rules that will be followed by the measurements capable of this feature (MLS and Sinusoidal).

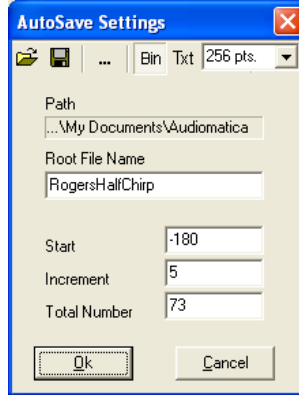


Fig.5.3 Autosave settings

There are five settings which serve to define the autosaved file name:

Path defines the folder where the file will be saved; it is possible to choose it clicking on the browse for folder button (...). In Fig.5.3 we see path defined as My Documents\Audiomatica

Root File Name defines the part of the file name that will not change during autosave; in Fig.5.3 it is 'RogersHalfChirp'.

Start defines the initial number appended to the root. This number will always be multiplied by 100 to give space for two decimals management. Numbers are appended with spaces. In Fig.5.3 start is -180; this will define the first autosaved file name as 'My Documents\Audiomatica\RogersHalfChirp -18000'

Increment defines the increment to be given to the autosaved file names. In the example of Fig.5.3 the second autosaved file will be named 'My Documents\Audiomatica\RogersHalfChirp -17500'

Total Number defines the number of autosaved files after which the process is automatically ended

It is possible to choose to save in the standard binary file format (Bin) and/or to export in text format (Txt) (see also 5.3.3); the drop down chooses the number of export data points for MLS files.

It is possible to save (and load) these definitions in particular files called Autosave Definition Files (*.asd).

5.3.2 EXPORTING DATA

 CLIO is able to export the currently active measurement in an ASCII file (*.txt).

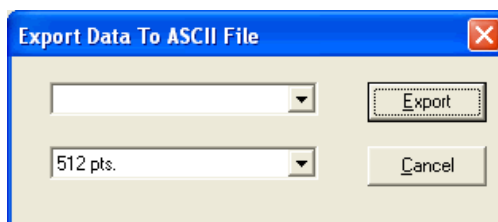


Fig.5.4 Export dialog

Upon performing this choice you will be prompted by the Export dialog. Depending on the measurement menu you are working with, it will be possible to choose different data to export. Here is a list of the possibilities, menu by menu:

MLS > Display Frequency Data

The program will export the frequency data as they are displayed on the screen, with resolution variable from 256 to 2048 points, regardless the current MLS size.

MLS > FFT Frequency Data

The program will export the frequency data with the resolution of the current MLS size.

MLS > Time Data

The program will export the acquired impulse response or active post process.

FFT > Display Frequency Data

The program will export the processed frequency data as they are displayed on the screen, with its internal resolution of 2048 points, regardless the current FFT size.

FFT > FFT Frequency Data

The program will export the processed frequency data with the resolution of the current FFT size.

FFT > Last FFT Data

The program will export the last calculated FFT frequency data with the resolution of the current FFT size.

FFT > Last Time Data

The program will export the last captured time data with the resolution of the current FFT size.

Sinusoidal > Frequency Data

The program will export the acquired frequency data with their fraction of octave frequency resolution.

Sinusoidal > Frequency Data + Harmonics


As above plus harmonics data.

T&S > T&S Parameter

Linearity&Distortion > Distortion data

Wow&Flutter > Wow&Flutter data

5.3.3 EXPORTING GRAPHICS

 CLIO is able to create **enhanced metafiles** (*.emf), **bitmaps** (*.bmp), **portable network graphics** (*.png), **JPEG** (*.jpg) or **GIF** (*.gif) of the currently active measurement. The graph is drawn using the same color of printouts; you can define them with the Options dialog, see 5.3.6.

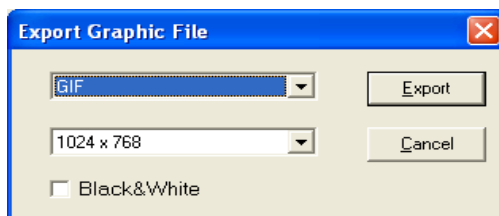



Fig.5.5 Export Graphics dialog

Check the **Black&White** box to discard color information.

5.3.4 PRINTING

 Enters the Notes dialog where it is possible to input comments to be saved with the actual measurement and inspect other measurement information. Check boxes enable printing notes and exporting notes to graphics files.

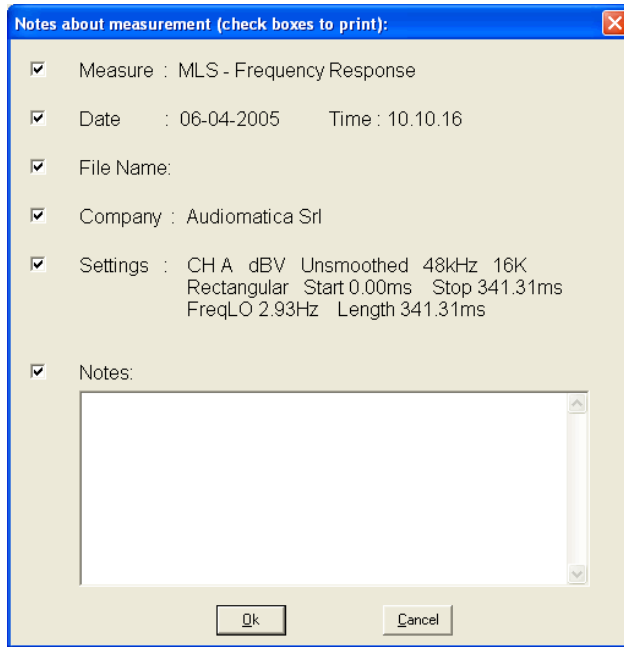




Fig.5.6 Notes dialog

 Prints the current active measurement. The definition of printing colors is done with the Setup dialog, see 5.3.5.

5.4 OPTIONS

 Opens the CLIO Options dialog box (Fig.5.7)

Options > General

Opening this tab (Fig. 5.7) you can define the following:

- The **Company Name** which will appear in all printouts.
- Some **On Exit** settings regarding when the program has to prompt and if you want to autosave and reload the measurement session (see 5.5).
- The **Signal Generator prompts**.
- The behavior of the **Input Peak Meter** to automatically change input sensitivity when overload is detected.
- The location of the **Hardware Controls Toolbar**.
- Some behaviour of the graphic curve display (see Chapter 6).

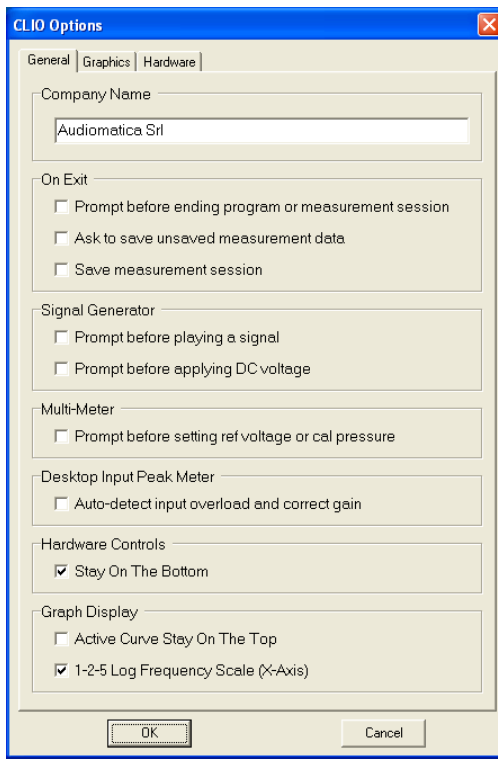


Fig.5.7 Options General dialog

Options > Graphics

Opening this tab you can define the following:

- Screen Colors
- Print (and graphics export) colors
- Screen line width
- Print (and graphics export) line width and font size.

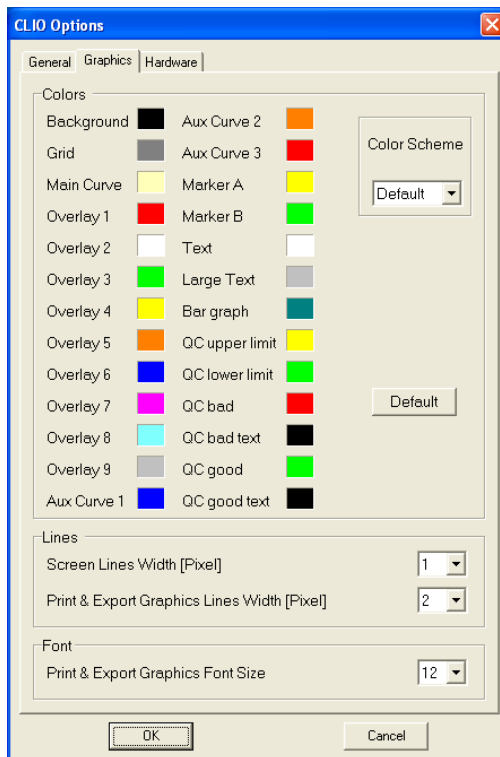


Fig.5.8 Options Graphics dialog

Apart from the Default color scheme, which is not changeable, it is possible to load and customize up to 6 different color schemes: Classic (for CLIO 6 users), User1, User2, User3, User4 and Printing.

The **Printing** color scheme, as the name implies, will affect your printouts (and exported graphic files) and, if selected, will let you preview how they appear on your screen.

Default button

When defining a color scheme you may press the Default button which will load the Default scheme for your reference. If you are modifying the printing color scheme it will load the default printing colors.

Options > Hardware

In case of QC software version it is also possible to select the **serial port** used to control external RS-232 devices. It is also possible to select the **TCP port** to be used by the QC measurement server

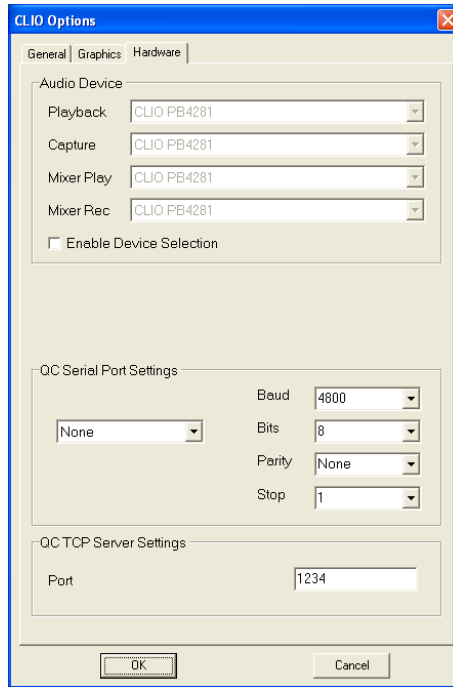


Fig.5.9 Options Hardware dialog


5.5 DESKTOP MANAGEMENT

Desktop management is a powerful feature that lets you save your work at a certain point and reload exactly as it was.

It is possible to do this automatically when exiting CLIO; at successive startup the program will automatically reload from where you left; to do this activate the **Save measurement session** from CLIO General Options.

 Load a previously saved measurement session (*.sna files).

 Takes a snapshot of current measurement session and saves it to disk (*.sna files).

 If pressed clears current measurement desktop i.e. closes and resets all measurement menu. It is also possible to clear one single measurement selectively opening and choosing from the associated drop down menu.

5.6 CALIBRATION

File > Calibration

This option will perform a calibration of your CLIO hardware. Please refer to paragraph 3.7 and follow the procedure described.

In order to determine, at any given time, if it is necessary to calibrate CLIO do the following:

- Let the system warm up
- Proceed to perform the verification described in 3.7.1
- Consequently decide whether or not to calibrate

The result of the measurement may vary in some way from the time we calibrated because of many small changes in measurement conditions, including changes in the atmospheric conditions, the season, and the mains voltage.

Note: the CLIO hardware is highly precise and stable and, under normal operating conditions, does not require frequent calibrations.

Always perform a calibration if:

- **CLIO asks for it showing the “System Not Calibrated” message**
- **You reinstalled CLIO in a different computer**
- **You installed a software upgrade**

5.7 STARTUP OPTIONS AND GLOBAL SETTINGS

You can start CLIO directly clicking on the **CLIO.exe** executable that is saved in the installation directory (usually C:\Program Files\Audiomatica\CLIO 8); you may also access CLIO either from **Start Menu > Programs > CLIO 8** or creating a shortcut on your Desktop.

A second way to run CLIO is to click on a registered file; in this way you will not only run the program but also load the file into the appropriate measurement menu.

CLIO creates a **temporary folder** for several uses. This folder is located under the Common Application Data folder with the following path:

C:\Documents and Settings\All Users\Application Data\Audiomatica\Temp

CLIO relies, during startup, on a configuration file named **clio.stp** which resides in the temporary folder.

This file is written each time the program ends and saves several settings that will be reloaded and reconfigure your system.

Among them we find:

- program Options (see 5.4)
- generator output level (see 4.4.2)
- input sensitivity (see 4.4.3)
- phantom power supply state (see 4.4.3)
- autorange state (see 4.4.3)
- microphone settings (see 4.4.4 and 7.4.1)
- CLIOQC Amplifier & SwitchBox settings (see 4.4.5)
- color scheme and other setup settings (see 5.3.6)
- main window state
- multi-meter generator control state (see 7.2.1)
- global reference level (see 7.3.3)

- autoscale state (see 4.4.6)

Note: It is possible to return the system to its initial default state (after installation) by deleting the `clio.stp` file.

5.7.1 SAVING MEASUREMENT SETTINGS

Measurements settings can be saved from within the various measurement menu; to do this simply check the Save Settings box in the Settings dialog of each menu (Fig.5.10); refer to specific menu chapters for details on settings.

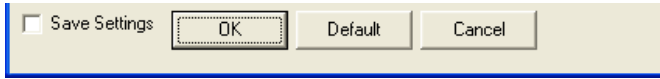


Fig.5.10 Save Settings check box

Settings are saved in the **mls.stp** (MLS&LogChirp), **sin.stp** (Sinusoidal), **fft.stp** (FFT), **wtf.stp** (Waterfall&Directivity), **acp.stp** (Acoustical Parameters) , **lin.stp** (Linearity&Distortion) , **leq.stp** (Leq) files inside the temporary folder.

Upon finding one of these files CLIO will reset the corresponding menu to the saved settings.

6 COMMON MEASUREMENT INTERFACE

6.1 INTRODUCTION

This chapter deals with the graphical user interface which is used to display and manage the measured curves within all CLIO frequency measurement menus. In particular this Common Measurement Interface (CMI) is used by the FFT, MLS and Sinusoidal menu. The understanding of CMI behavior and capabilities is very important to use CLIO at its best.

6.2 UNDERSTANDING THE DISPLAY IN FRONT OF YOU

Fig.6.1 explains the main objects found in a frequency response measurement display.

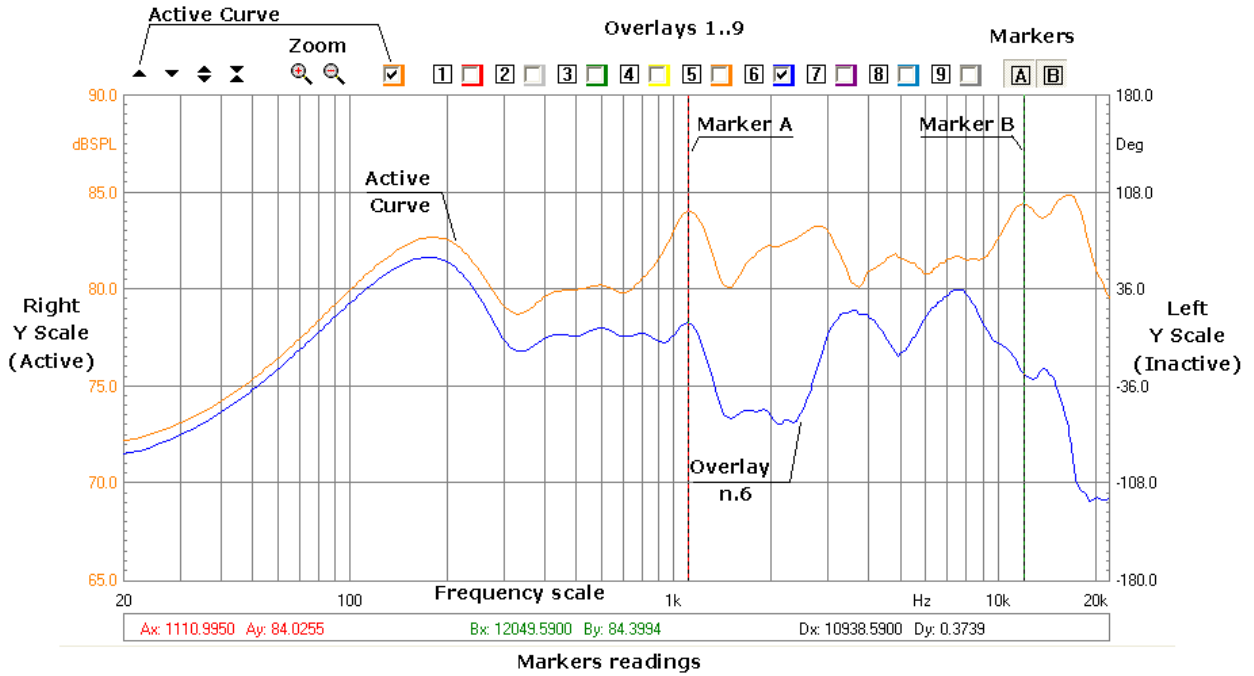


Figure 6.1

Inside the graph you find the **active curve** which reflects an executed (or loaded from disk) measurement; up to nine **overlays curves** which are stored by the user and can be switched on and off interactively, the two **markers** which are activated by clicking on the respective buttons.

Above the graph itself we find several buttons and checkboxes which divide into three main categories: active curve, zoom and overlays management.







Beside and below the graph we find the Y Scales, the Frequency (or Time) Scale and Marker Indicators. One of the two Y scales is of the same color of the active curve and refers to it. The marker indicators give the user the reading of the active curve.

The objects described may, from case to case, not all be present at the same time, as in the case of Time Data display in the FFT menu. The frequency (or time) scale may be logarithmic or linear. A particular representation is the MLS time domain which will be discussed later in 6.6.


It is possible to have two graphs in the same control panel (see FFT). In this case one is referred as active after you have clicked on it.

To change the colors of the screen, active curve and overlays refer to section 5.4.

6.3 BUTTONS AND CHECKBOXES

-  Moves (shifts) the active curve upward.
-  Moves (shifts) the active curve downward.
-  Expands (magnifies) the active curve; it also changes the Y scale respectively.
-  Compresses (reduces) the active curve; it also changes the Y scale respectively.
-  Zooms the active curve in; it is possible to execute multiple zoom in actions.
-  Zooms out the active curve completely i.e. returns to the default initial zoom state.
- Before the overlays controls (left to right) switches the active curve on and off.
- Stores the active curve into overlay 1. It also displays overlay 1.
- Stores the active curve into overlay 2. It also displays overlay 2.
- Stores the active curve into overlay 3. It also displays overlay 3.
- Stores the active curve into overlay 4. It also displays overlay 4.
- Stores the active curve into overlay 5. It also displays overlay 5.
- Stores the active curve into overlay 6. It also displays overlay 6.
- Stores the active curve into overlay 7. It also displays overlay 7.
- Stores the active curve into overlay 8. It also displays overlay 8.
- Stores the active curve into overlay 9. It also displays overlay 9.
- Switches the respective overlay on and off. It also shows the color of the overlay.
- Enables marker A.
- Enables marker B.

6.4 HOW TO ZOOM

- 1) Click on the Zoom+  button.
- 2) Position the mouse and PRESS the left mouse button at the beginning of your selection and **keep the mouse button pressed**. Don't just click otherwise you get a warning message!

3) With the mouse button pressed move the mouse until the second selection point.

4) Only now release the left mouse button.

Be careful: you must have the button pressed from point 2) to point 4)!

6.5 SHORTCUTS AND MOUSE ACTIONS

The following keystrokes and mouse actions are active:

up arrow

equivalent to ▲ on the active graph

Shift+up arrow

equivalent to ◆ on the active graph

down arrow

equivalent to ▼ on the active graph

Shift+down arrow

equivalent to ⚡ on the active graph

mouse click

activates the graph; useful when more than one graph is present (see FFT)

mouse left down

activates the marker

mouse left drag

moves the marker

mouse wheel up

equivalent to ▲

mouse wheel down

equivalent to ▼

6.6 THE MLS TIME DOMAIN DISPLAY

When entering the MLS (but also Waterfall or Acoustical Parameters) time domain you will find a different display (Fig. 6.2).

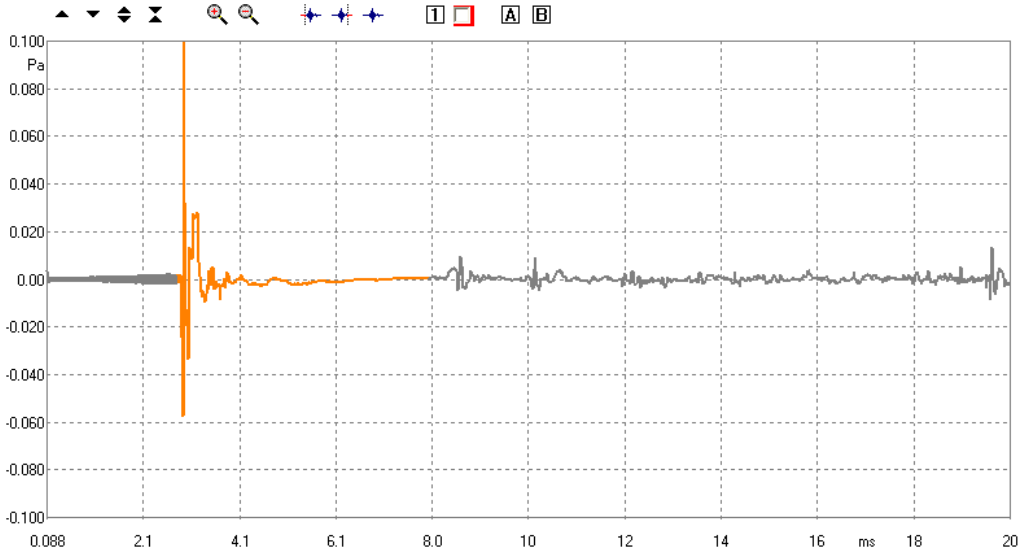




Figure 6.2

In this case there is only one overlay. It is also possible to **select** a portion of the active curve by means of three particular buttons. The selected portion of the active curve is identified by a **start** and **stop** point and is drawn in a different color from the unselected portion.

 Defines the **start point** of the selection. **Before clicking with the button activate Marker A and position cursor to the desired point.**

 Defines the **stop point** of the selection. **Before clicking with the button activate Marker A and position cursor to the desired point.**

 Returns the curve to a completely unselected state.

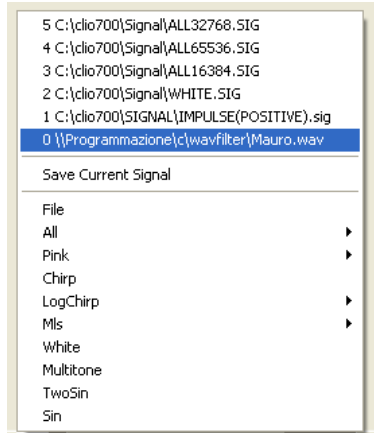
7 SIGNAL GENERATOR

7.1 INTRODUCTION

This chapter deals with the programmable signal generator of CLIO. Each paragraph explains a type of signal, its settings and gives a time frequency analysis obtained with the FFT narrowband analyzer (see chapter 9).

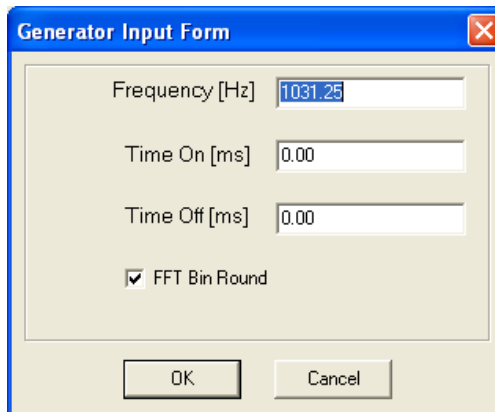
Refer also to 4.4.3 for all hardware and software controls associated with the signal generator.

Clicking on the generator button drop down you access the signal generator menu.



7.2 SINUSOID

It is possible to generate sinusoids of given frequency. Select the Sin choice in the generator menu.

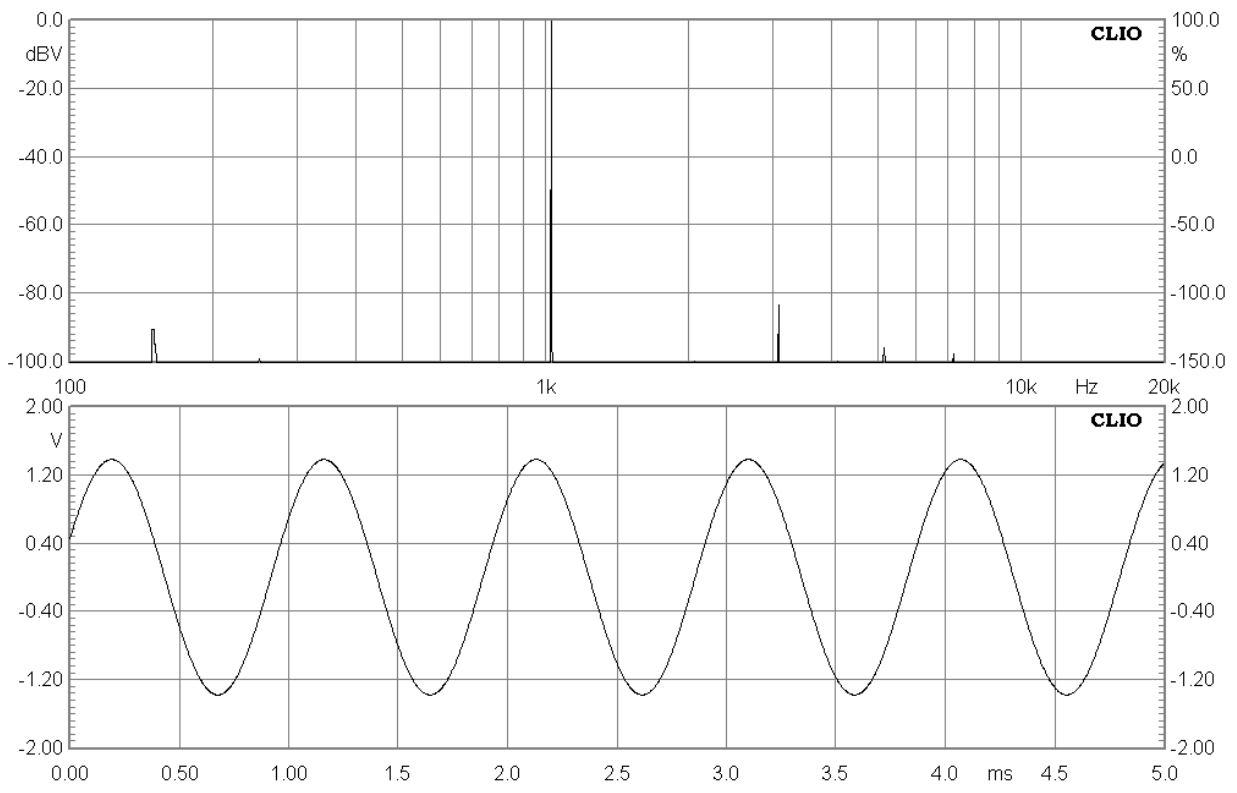


The sinusoid can be **continuous**; leave the two inputs Time On and Time Off at zero.

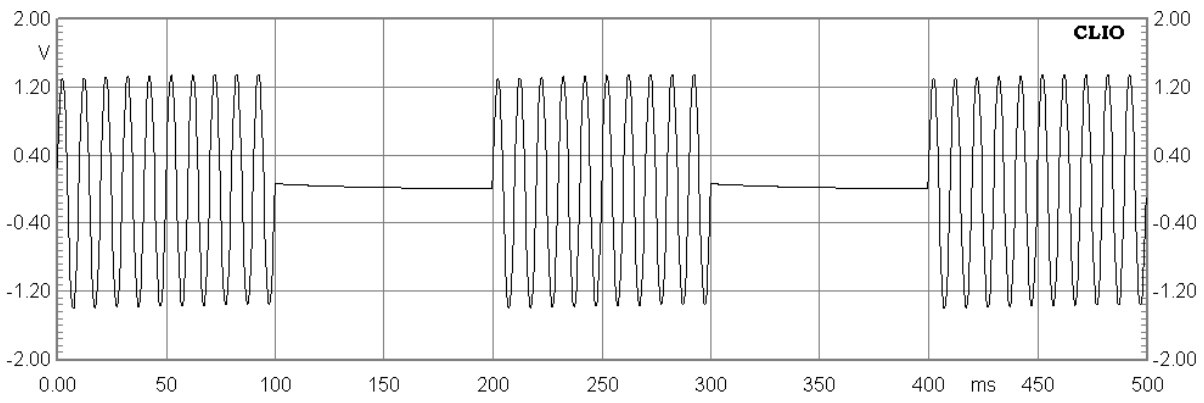
Or it can be **bursted**; input the desired values in the Time On and Time Off inputs.

Select **FFT Bin Round** if you desire that the frequency is approximated to the nearest FFT bin (with respect to the actual FFT size setting). Please refer to 9.5 for a detailed explanation of this feature.

The following figure shows a 1031.25Hz continuous sinusoid.

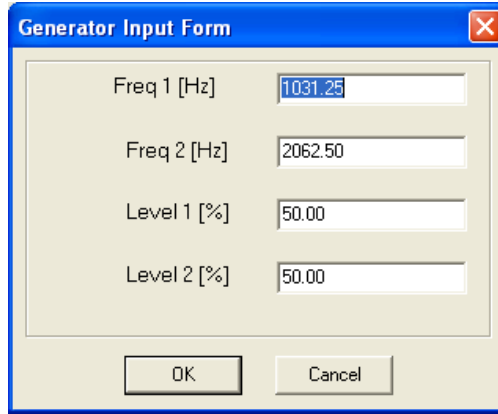


The following figure shows a 100Hz bursted sinusoid.



7.3 TWO SINUSOIDS

It is possible to generate two sinusoids of given frequencies and amplitudes. Select the TwoSin choice in the generator menu.

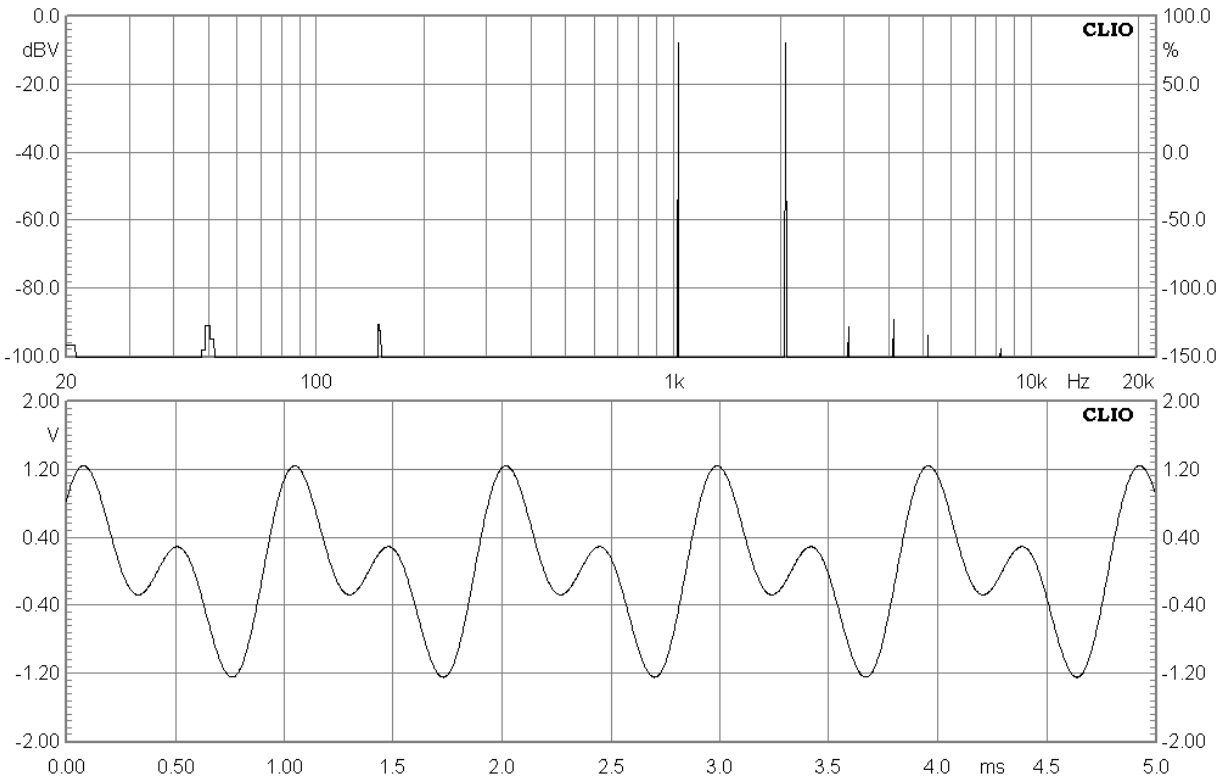


Generator Input Form

Freq 1 [Hz]	1031.25
Freq 2 [Hz]	2062.50
Level 1 [%]	50.00
Level 2 [%]	50.00

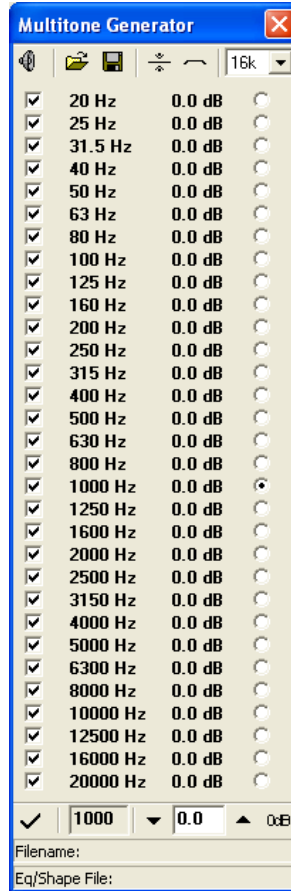
OK Cancel

The following figure shows a signal consisting of a 1031.25Hz and 2062.5Hz of same amplitude (50% each).

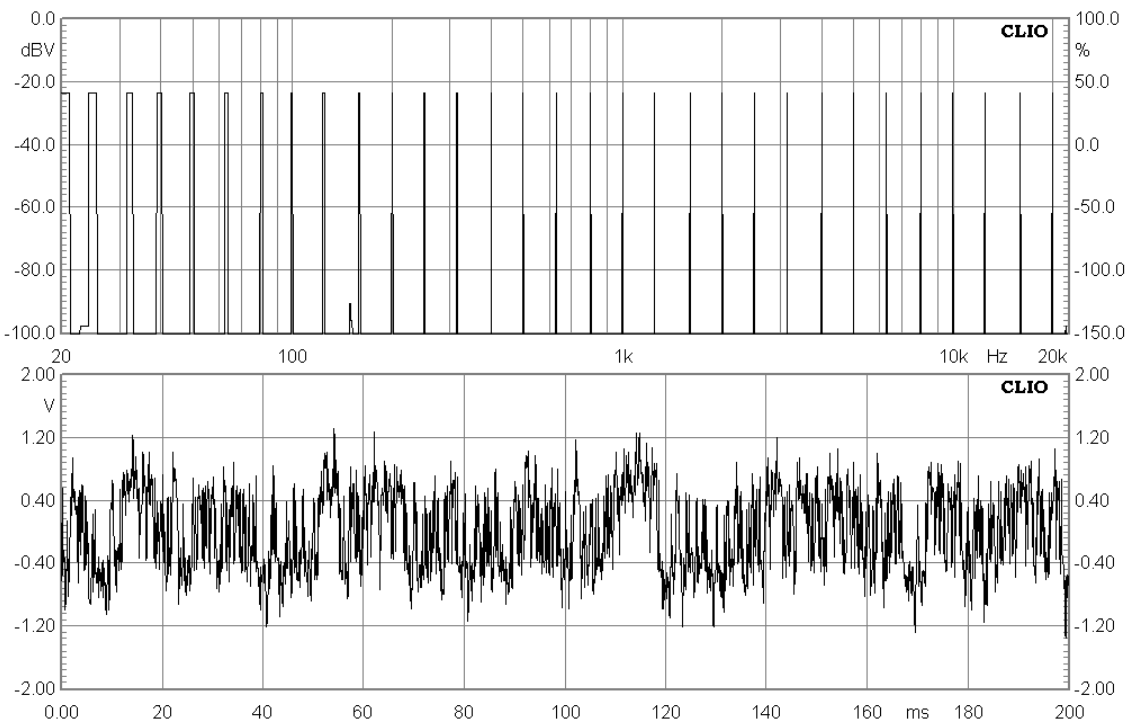


7.4 MULTITONES

It is possible to generate multitones (multiple sinusoids signals). Select the Multitone choice in the generator menu.



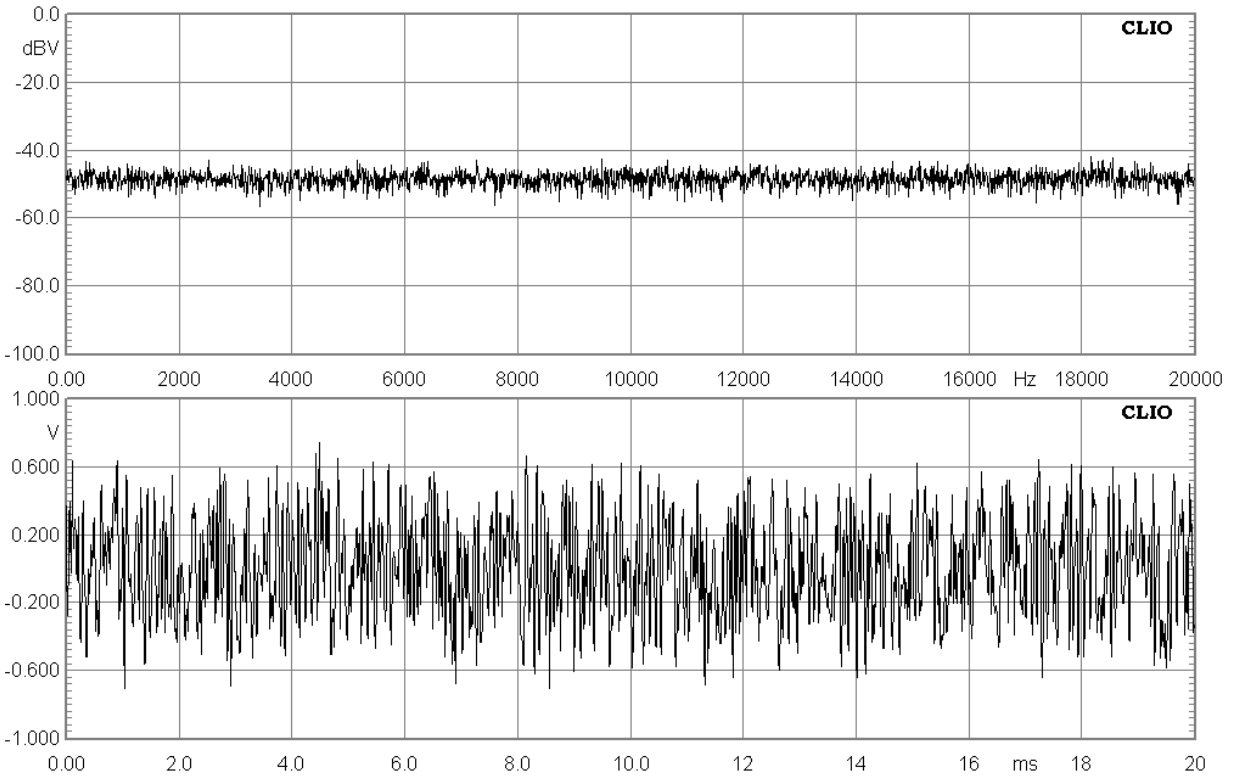
The following figure shows a multitone signal consisting of 31 sinusoids each with frequency corresponding to the center frequencies of the standard 1/3rd of octave bands from 20Hz to 20kHz and same amplitude.



7.5 WHITE NOISE

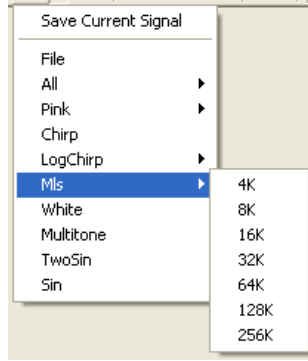
It is possible to generate a white noise. Select the White choice in the generator menu.

The following figure shows the white noise signal.



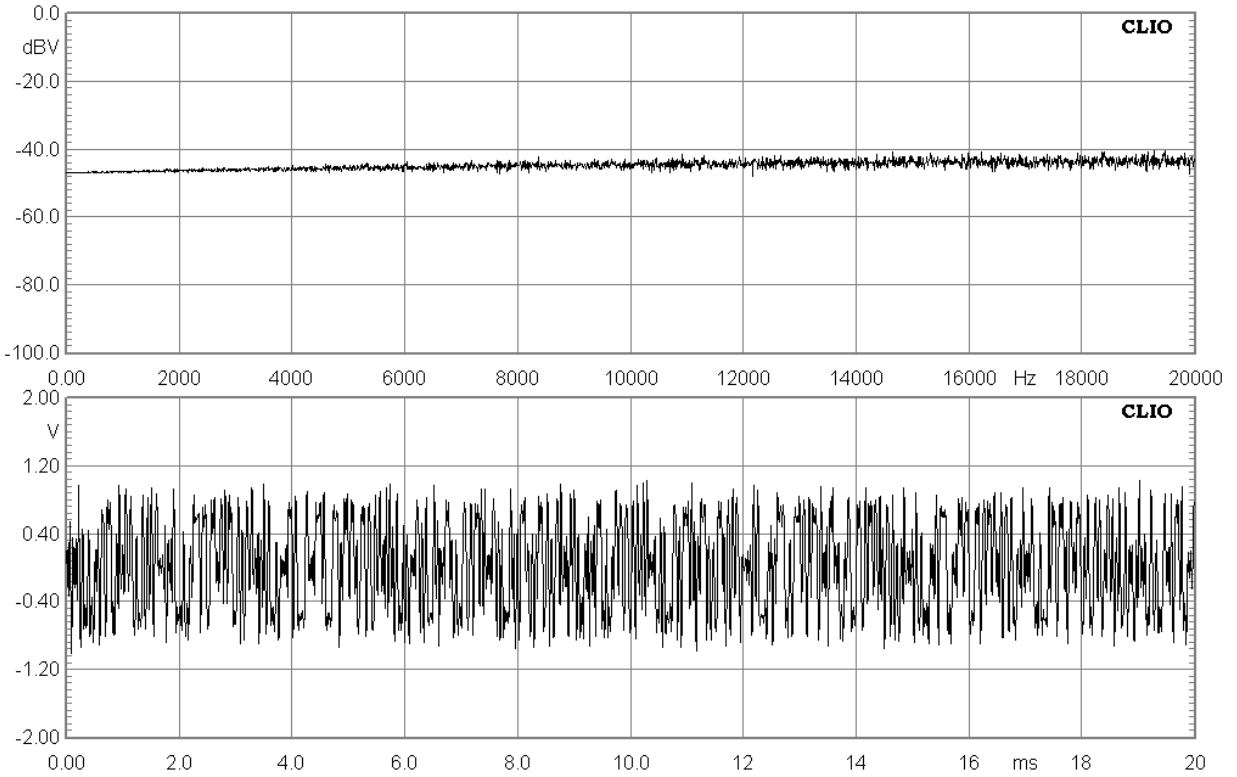
7.6 MLS

It is possible to generate MLS (maximum length sequences) of given length. Select the MLS choice in the generator menu.



These signals are the same used in the MLS analysis menu and should be used to test them.

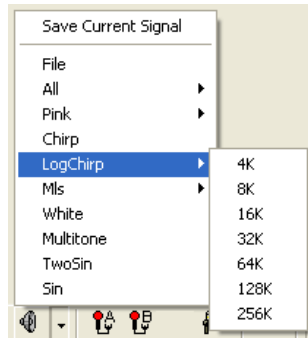
The following figure shows a MLS signal of 32k length.



7.7 CHIRPS

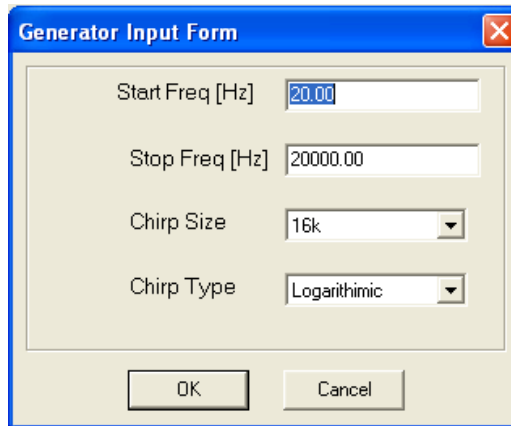
It is possible to generate Chirps (sinusoids with frequency continuously variable with time between two extremes) in two different ways.

You may generate full spectrum Logarithmic Chirps of given length selecting the LogChirp choice in the generator menu.

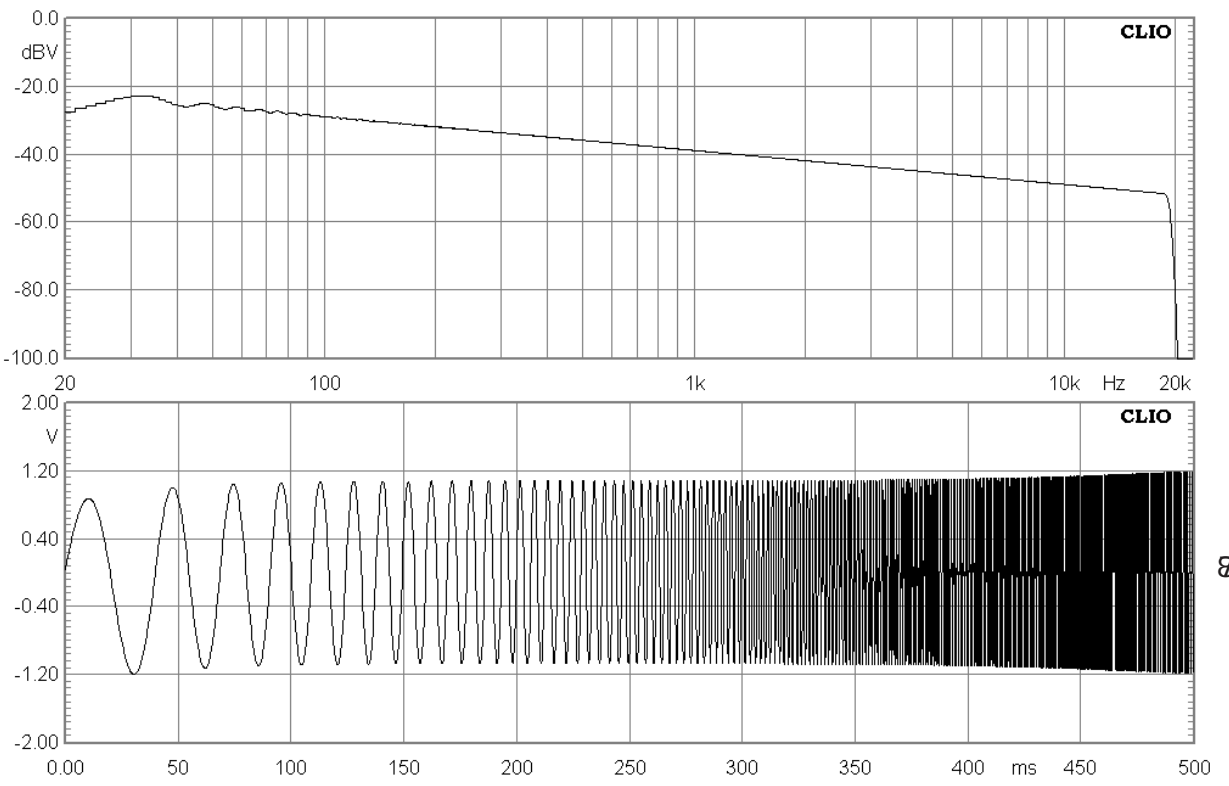


These signals are the same used in the LogChirp analysis menu and should be used to test them.

You may instead define Chirps of given length, frequency extremes and kind (linear or logarithmic) selecting the Chirp choice in the generator menu.

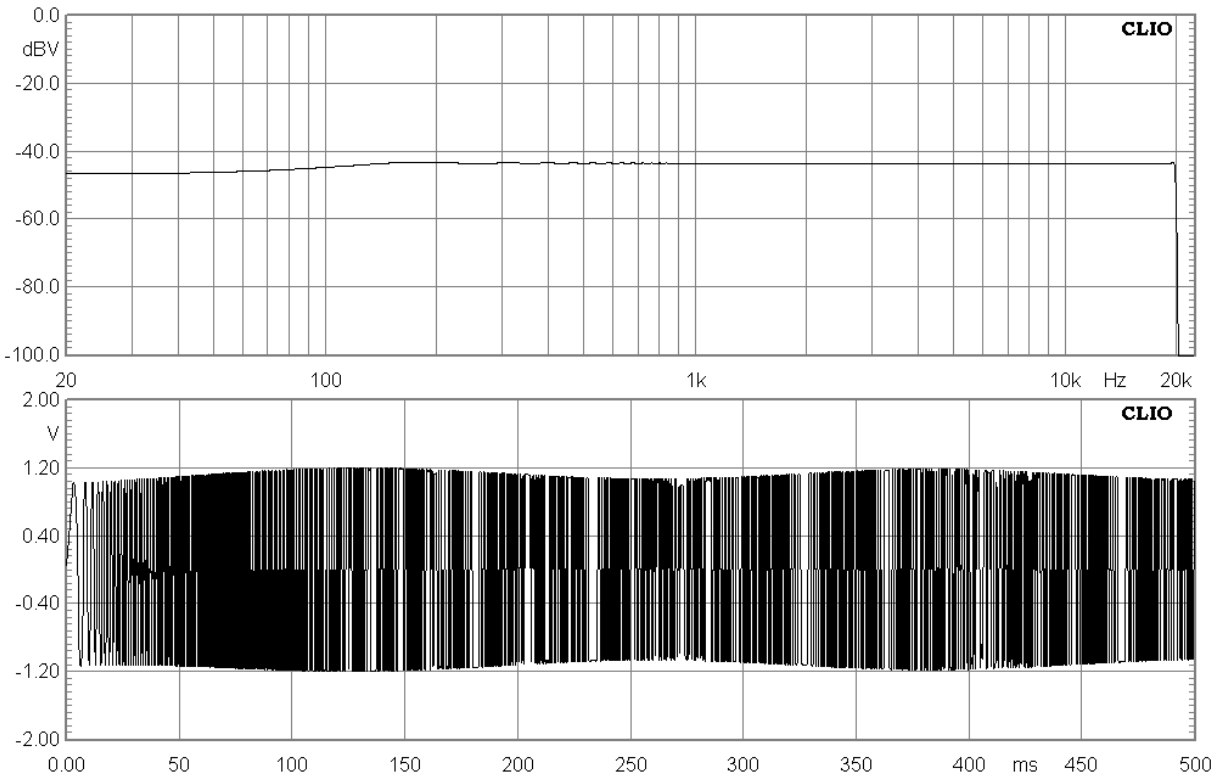


The following figure shows a 20Hz to 20 kHz Log Chirp.



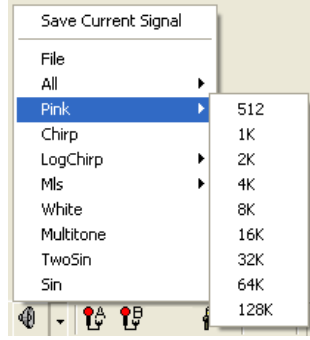
8

The following figure shows a 20Hz to 20 kHz Lin Chirp.

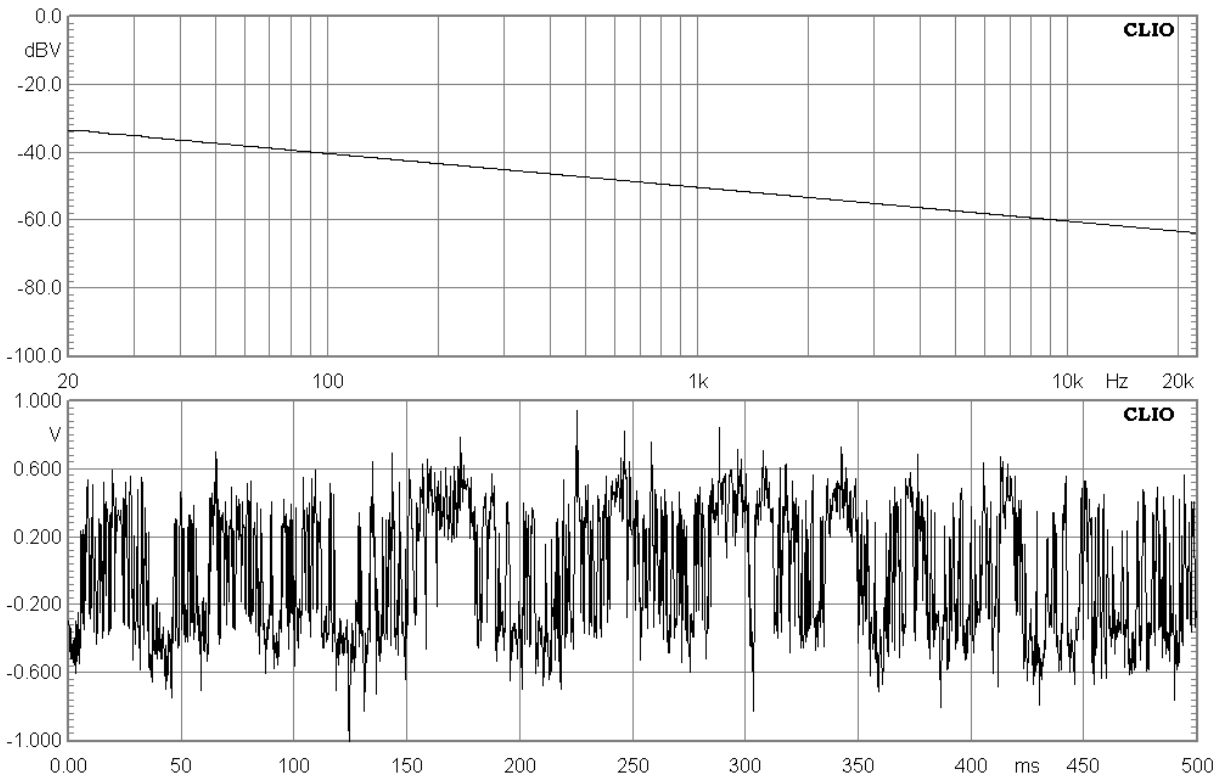


7.8 PINK NOISE

It is possible to generate Pink noises of given length. Select the Pink choice in the generator menu.

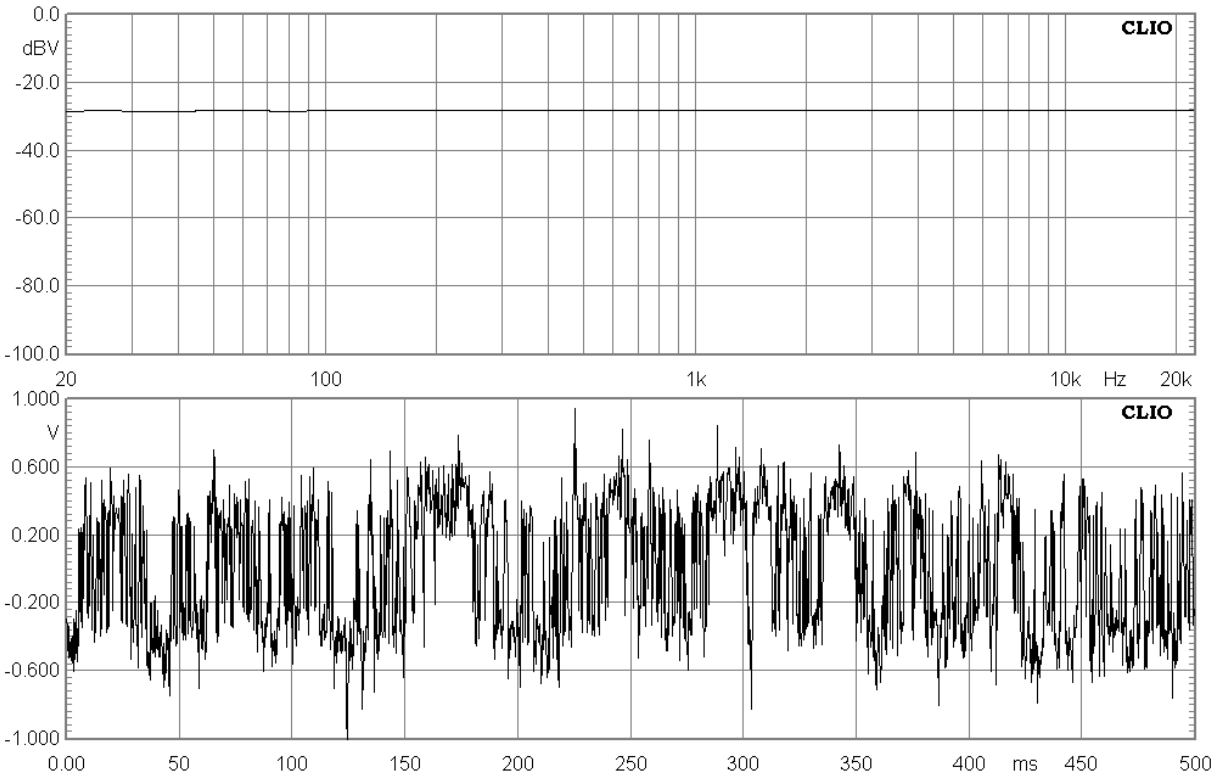


The following figure shows a Pink Noise signal of 32k length measured with the FFT narrowband analyzer.



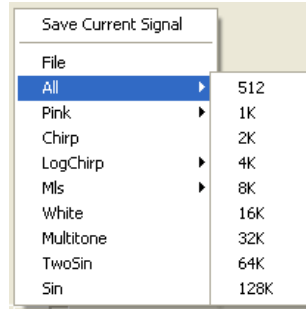
Pink noise signals are used normally to execute Octave bands analysis with the RTA menu due to the flat reponse they produce when analyzed with fraction of octave filters.

The following figure shows the same Pink Noise signal of above measured with the RTA analyzer.

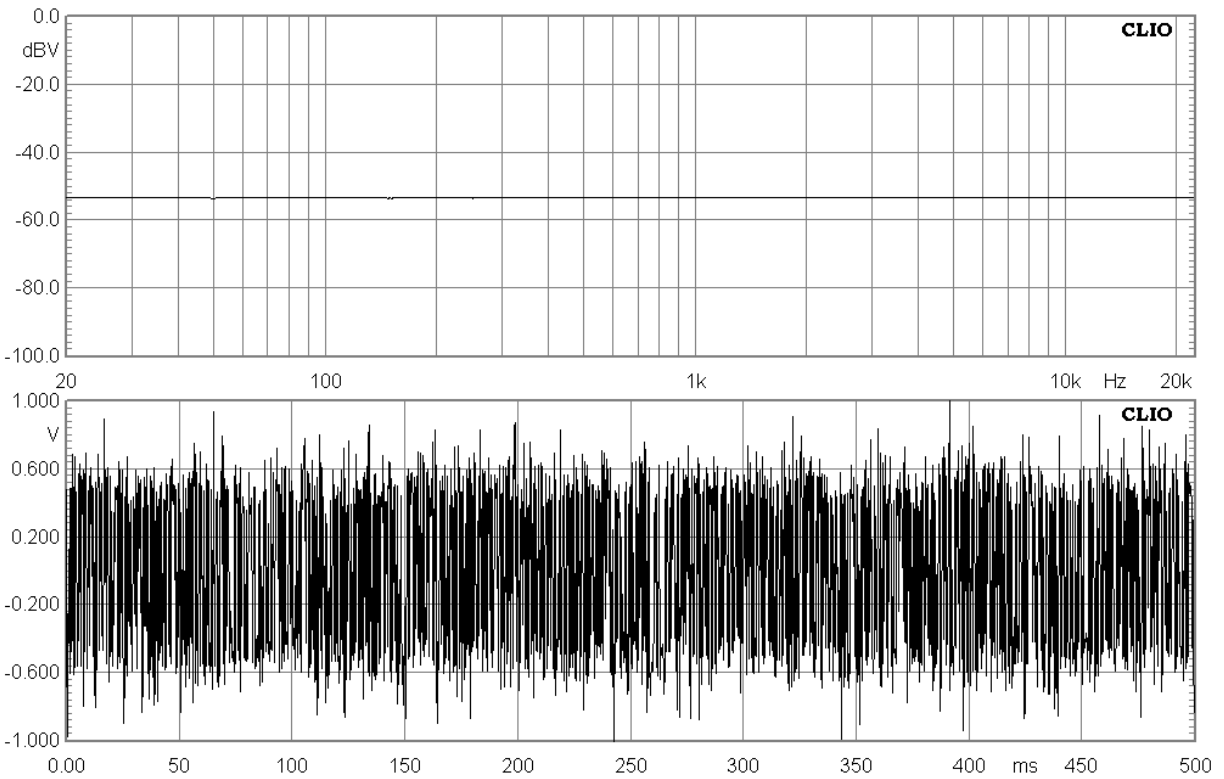


7.9 ALL TONES

It is possible to generate All Tones signals of given length; an All tones contains a sum of sinusoids of frequencies corresponding to each frequency bin with respect to their length and sampling frequency. Select the All choice in the generator menu.

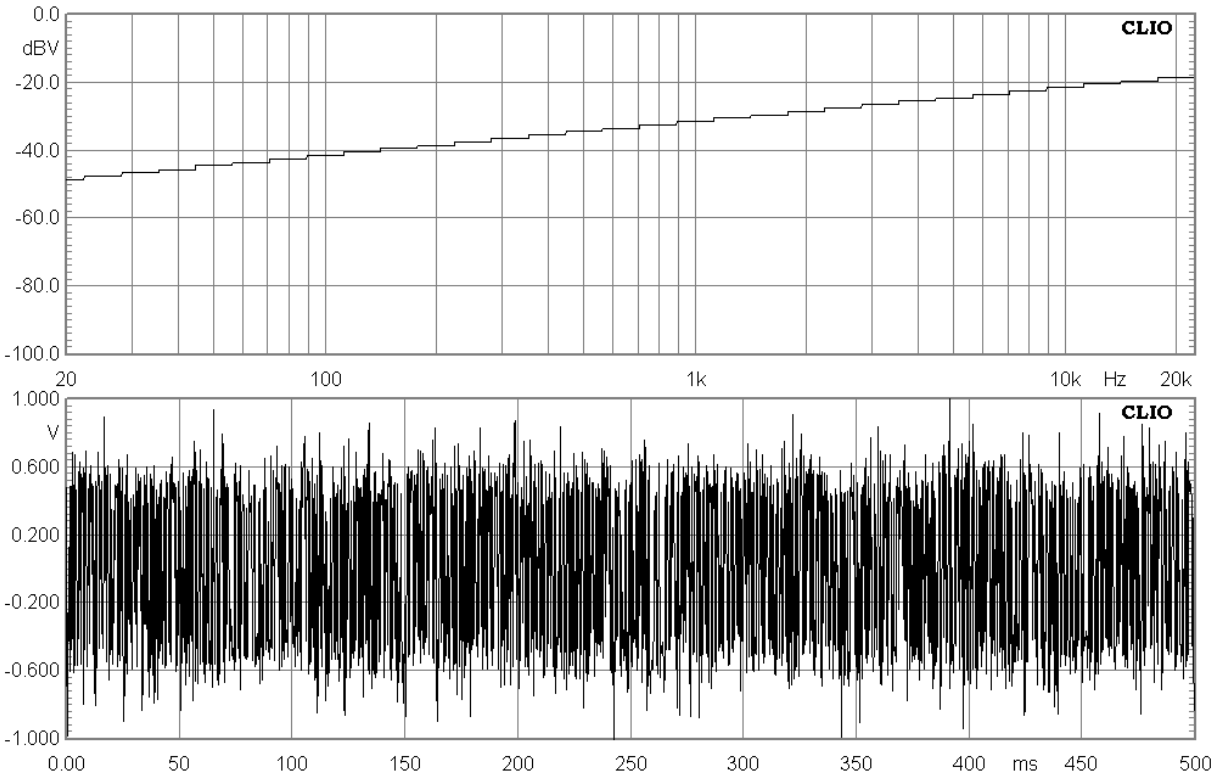


The following figure shows an All Tones signal of 32k length measured with the FFT narrowband analyzer.



All Tones signals are used with the FFT narrowband analyzer due to the flat response they produce.

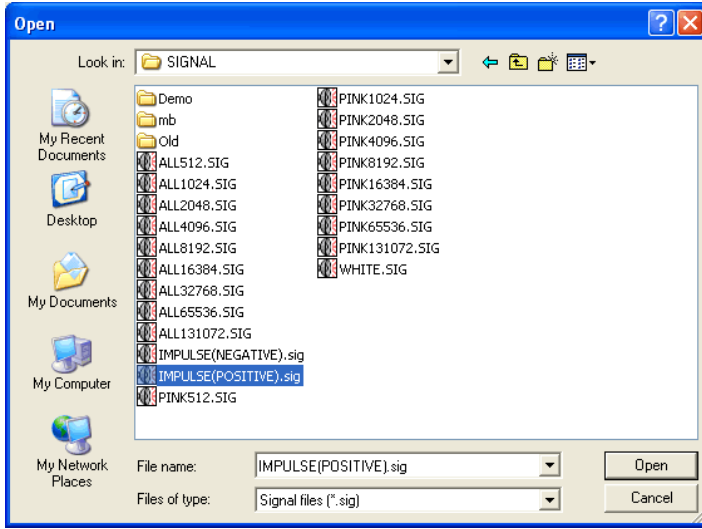
For comparison with Pink noises the following figure shows the same All Tones signal of above measured with the RTA analyzer.



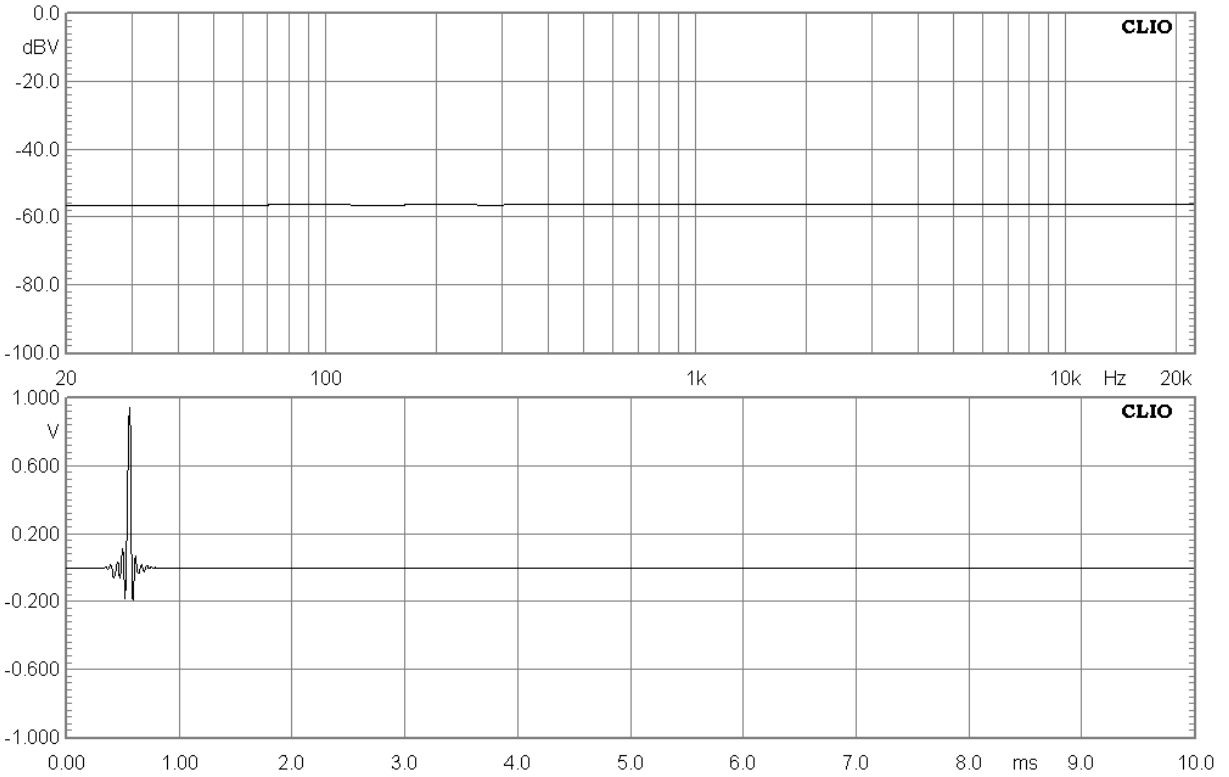
7.10 SIGNAL FILES

As a last possibility it is possible to play signal files saved on disk. Two formats are supported: **'.sig'** CLIO Signal files and **'.wav'** standard Windows Wave files.

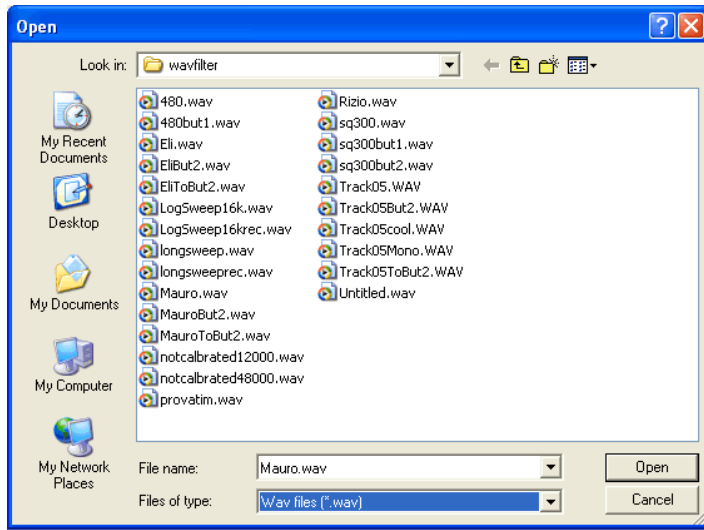
Choose File within the generator menu. The default extension lets you select a CLIO signal file.



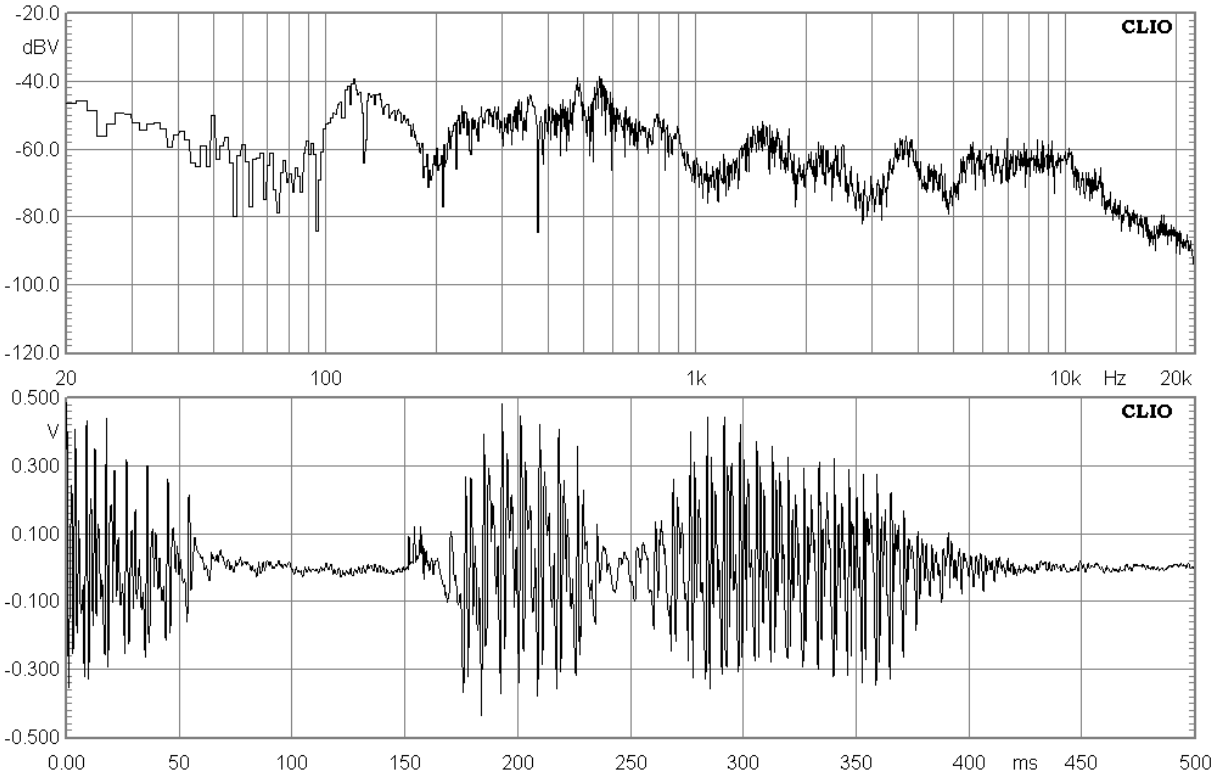
The following figure shows the IMPULSE(POSITIVE).SIG signal file.



You may instead change the extension to select wav files.



The following figure shows a sample of voice saved in a wav signal file.



The generator menu also keeps track of the **recently** generated signal files giving you instant access to them.

7.10.1 SAVING SIGNAL FILES

The generator menu allows you also to save the current signal present in memory to file. To do this choose Save Current Signal; formats supported are .sig and .wav.

Please note that it is possible to generate .wav files from the Leq measurement menu; the data captured during Leq measurements can then be saved to disk and later reproduced with the signal generator.

8 MULTI-METER

8.1 INTRODUCTION

The Multi-meter is an interactive, real-time, measuring instrument.

It gives CLIO the functionality of a:

- **Sound level meter (dBSPL, dBA, dBC)**
- **Millivoltmeter (V, dBV, dBu, dBr)**
- **Frequency counter (Hz)**
- **Distortion meter (% , dB)**
- **L-C-R bridge (H, uF, Ohm)**

Recallable simply pressing **F4**, the Multi-meter has the capability of **capturing the global reference level and the microphone sensitivity**; it is rare that you enter CLIO and don't use the Multi-meter, the information and controls available here are of invaluable importance during the normal operation of the whole instrument.

8.2 MULTI-METER CONTROL PANEL

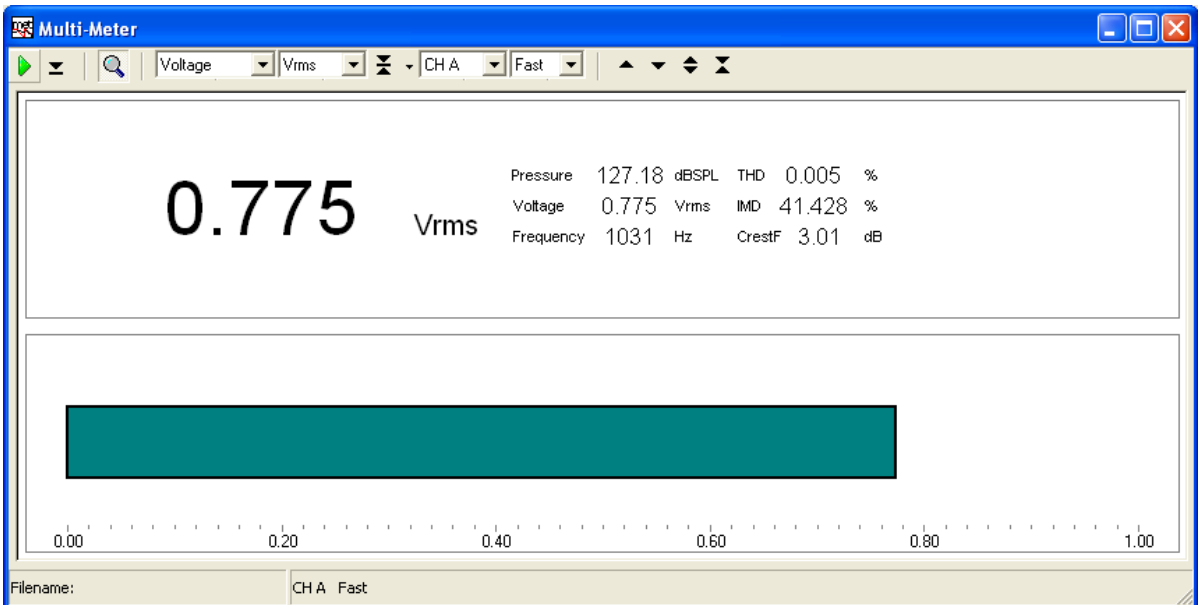








Figure 8.1 Multi-meter control panel

8.2.1 TOOLBAR BUTTONS

-  Starts the measurement.
-  Permits execution with the control panel in a minimized state. Only a small stay-on-the-top display remains visible. See 8.3.2.
-  Stops the measurement.
-  If pressed displays all measured parameters.
-  Captures the actual reading of the multi-meter as the global reference level (or microphone sensitivity); refer to 8.3.2 and 8.4.1 for details.
-  Control the scale of the meter bar graph.

8.2.2 TOOLBAR DROP DOWN LISTS

parameter

Selects the parameter to be measured.

unit

Selects the measurement unit.

channel

Selects the input channel.

integration

Selects between fast (125ms) and slow (1s) integration. Not applicable to the LCR meter.

8.3 USING THE MULTI-METER

The first application of the Multi-meter has been described in section 3.4.1 when CLIO was started for the first time. This was a simple generation of a 1kHz sinusoid (0dBu output level) and relative level capture with the Multi-meter. You can continue the measurement described to familiarize yourself with the instrument. Pressing the magnifier will let you inspect all the parameters that the Multi-meter measures in parallel (Fig.8.1); changing the selected parameter will bring it to the foreground; for any parameter it is possible to choose different units, for example THD can be shown in percentage or in dB; then you can select the input channel and the integration. This last parameter (**integration**) affects the measurement rate, since the integration **fast** assumes **125ms** of exponential averaging while the integration **slow** assumes **1s** of exponential averaging. The program approximates these constants trying to measure the computer speed and varying the number of averages calculated.

The rest of the paragraph deals with other applications of the Multi-meter.

8.3.1 THE MINIMIZED STATE

It is possible to operate the Multi-meter in what we call a 'minimized' state. Pressing the relative button the control panel collapses and, in its place, remains a **stay-on-the-top** display as in Fig.8.2.



Figure 8.2

This operating mode is very useful; for example suppose you want to measure the total harmonic distortion of a sinusoidal signal while also displaying its frequency content. To do this lets start the FFT and Multi-meter control panels together; then press the Go button in FFT, this will start both measurements (see also 8.6 about this); inside the Multi-meter select the THD parameter and then press the minimized button. You should obtain a measurement situation like the one in Fig.8.3. In this figure we were directly acquiring the output of CLIO while generating a 1kHz sinusoid at 0dBu.

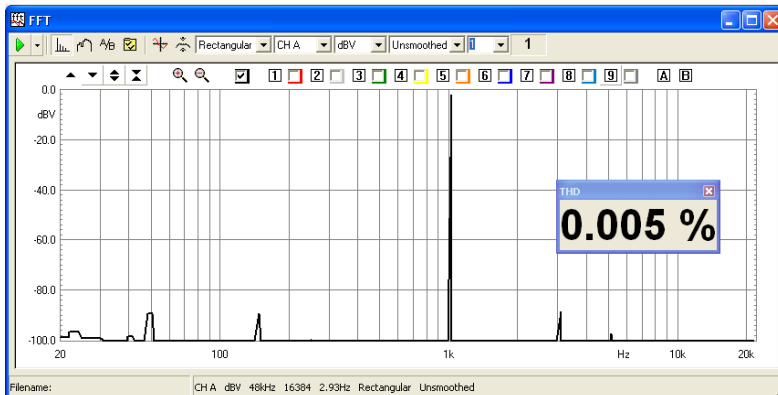



Figure 8.3

8.3.2 CAPTURING THE GLOBAL REFERENCE LEVEL

Now let's see how to capture a level to be the reference for other measurements. Once this is done all subsequent measurements from within the instruments can be referenced to this by choosing **dBREL** as the unit of measurement. As an example, let us go back to the procedure described in 3.5.1 which aims at validating a calibration.

This is substantially the measurement of the frequency response of the CLIO board itself which is, when calibrated, a straight line; as said in the cited procedure the acquired level of such a measurement is -5.2 dBV. Let's see a practical way to acquire this level in order to refer future measurements to it. Keep the instrument connected as in Fig.3.9, with input **A** and output **A** short circuited. Press the MLS button to start generating the MLS signal (the same signal that MLS uses during its operation). Press Go to start acquiring this signal, you should read circa 0.54V. Also select the Slow integration as the MLS signal is a wide band noise. While the measurement is running press the  button; answering yes to the warning message this will set the global reference level. To inspect the captured value press the button's drop down menu. You should see the situation in Fig.8.4.

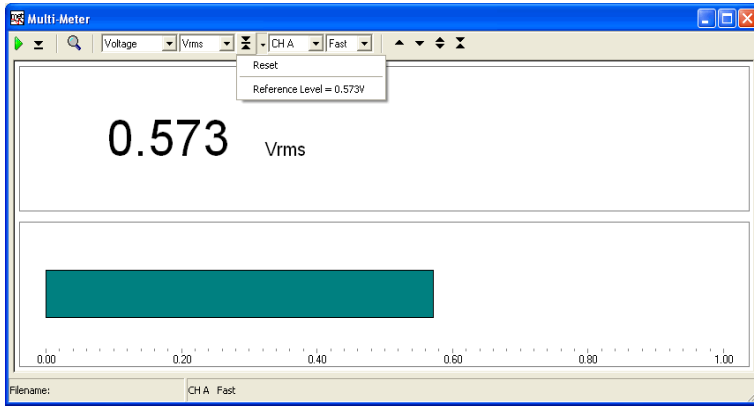


Figure 8.4

The drop down tells you what the actual global reference level is. If you want to restore the default, which is 1V, just choose **Reset**. Having completed this should you choose **dBRel** as your units expect to read 0dBRel!

But let's go to the MLS control panel and see how we can reference frequency response measurements. Open the MLS control panel and simply choose dBRel as units. Then start the measurement. You should obtain the results as shown in Fig. 8.5; a general tendency is always a straight line but now the reading is circa 0dBRel.

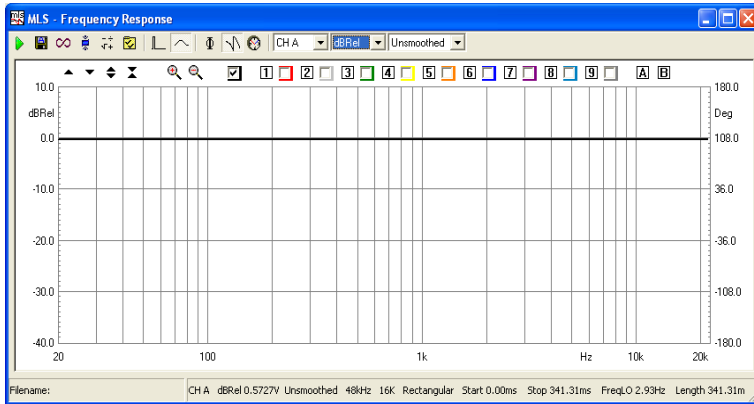



Figure 8.5

8.4 THE SOUND LEVEL METER

Selecting **Pressure** as measured parameter gives your Multi-meter the functionality of a Sound Level Meter. Three units are available: dB SPL, dBA and dBC. **dB SPL** is a direct reading of the sound level, relative to the reference pressure of 20uPa. Remember that CLIO needs to know your microphone sensitivity to carry out this measurement correctly (see 5.4.4). **dBA** and **dBC** are frequency weighted measurements and are usually requested to assess, for example, environmental noise or any human related annoyance. In these two cases the program post processes the measurement, applying the appropriate frequency filter as described in IEC-651 norms.

8.4.1 CAPTURING THE MICROPHONE SENSITIVITY

When measuring pressure, it is possible to calibrate your measuring chain if you have a pressure reference available like an acoustic calibrator. **It is possible to calibrate both channels.**

In this situation, pressing the  button will prompt the instrument to capture a pressure reading as reference for the reading channel; it expects a reference pressure level at its input, as furnished by the vast majority of acoustic calibrators; it is possible to input its value clicking on the drop down menu; the default value is **94dB**. As a result of this procedure the program will calculate the sensitivity, in mV/Pa, of the microphone front end, and store it in the CLIO settings.

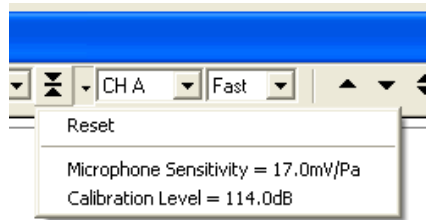



Figure 8.6

If you press the button's drop down you will see a reference to the actual Microphone sensitivity. In this case, differently from the case of Voltage measurements, the default measurement is 17 mV/Pa, which is a rough average of Audiomatica's microphones MIC-01 and MIC-02 sensitivity. Let's see how to capture the channel **A** microphone sensitivity. In Figure 8.7 you see a Bruel & Kjaer 4231 acoustic calibrator fitted to a MIC-02 microphone.



Figure 8.7

With the Multi-meter running, fit the calibrator in place and switch it on. Wait a few seconds for the measurement to stabilize. Then press the  button. You will receive the prompt in Fig.8.8.

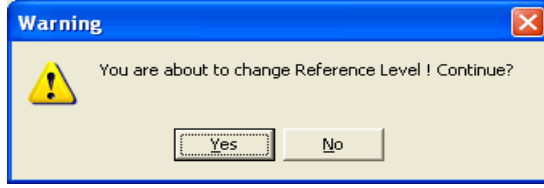


Figure 8.8

Be advised that, by answering yes, you will affect all pressure measurements executed with input channel A. You can inspect the newly acquired sensitivity entering the microphone sensitivity dialog (see 5.4.4).

8.5 THE LCR METER

This is a particular operating mode of the Multi-meter that gives you the possibility of measure inductors, capacitors and resistors. This measurement is an **impedance measurement** and is carried out in the **Internal Mode**; please use Chapter 13 as a reference concerning impedance, related connections and operations.

In this mode the Multi-meter takes control of the generator and, when the measurement is started, outputs a series of sinusoids of variable frequency in order to find the best one to carry out the measurement. The output frequency can be displayed (with the magnifier button) together with the measured parameter.

8.5.1 MEASURING AN INDUCTOR


Measuring an inductor is as easy as connecting it as in Fig.8.9, selecting the In-Out Loop with  and press Go. The most critical factor influencing this test are connections; as with all impedance measurements, if you use pin-to-alligators cables use great care in avoiding false contacts which may arise if terminals are oxidized or alligators loose their bite.



Figure 8.9

In a few seconds the measure stabilizes to the final result shown in Fig. 8.10. This was a 4.8mH nominal inductor; the panel also shows the test frequency that in this case is 2510Hz. The same procedure should be carried out when measuring resistors or capacitors.

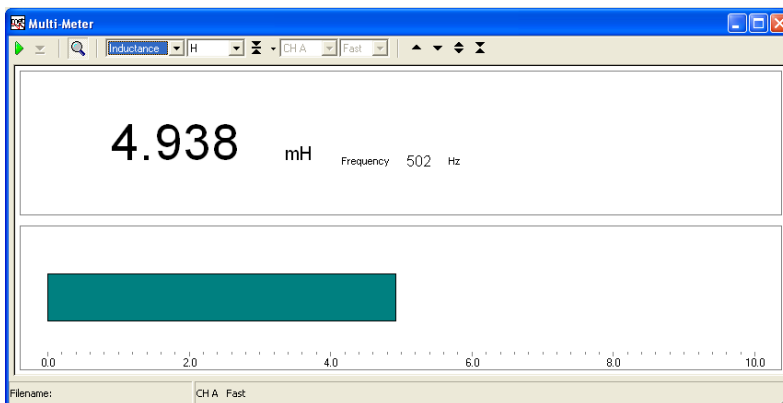


Figure 8.10

8.6 INTERACTION BETWEEN THE MULTI-METER AND FFT

The Multi-meter uses the same capture and processing units as the FFT control panel. To perform a measurement it programs the FFT routines (changing FFT settings to match its needs) and then effectively starts an FFT measurement in background.

The two panels can be opened and can work together but FFT always acts as the **master** while Multi-meter as the **slave**. In this situation the Multi-meter window's title is changed to '**Multi-Meter (FFT slave)**' to reflect this new state; the **Go and Stop buttons are disabled** as you operate the slave panel from inside FFT, starting and stopping the reading with the FFT's Go and Stop buttons; **the input channel follows the FFT one** while **the integration setting become meaningless**; this is because the user has control over FFT averages which precisely define the measurement integration. Nevertheless, during slave operation, it is possible to select the displayed parameter and its unit. It is not possible to select LCR operation as the LCR meter uses different measurement capabilities.

As soon as the FFT control panel is closed it releases Multi-meter from the slave state; then the Multi-meter is then ready to operate in a stand-alone capacity and is fully functional as described above.

9 FFT, RTA AND "LIVE" TRANSFER FUNCTION

9.1 INTRODUCTION

By selecting the FFT command from the main menu bar, it is possible to carry out Fourier analysis of the input signal to determine its frequency content using the Fast Fourier Transform (FFT).

The ability to process two channels simultaneously, to select the appropriate sampling frequency and the possibility of triggering with respect to the generated signal make this control panel a flexible and valuable instrument. Finally, there is also a very useful facility to quickly and easily swap back and forth between the time and frequency domains.

The FFT processed data coming from the two input channels can be displayed as **narrowbands**, **1/3** (or 1/6) **octave bands** (turning the instrument into what is generally called a real-time analyzer or **RTA**) or, referencing one to the other, as **live transfer function** (you may also use music as stimulus).

What you get are three different instruments in one.

9.2 NARROWBAND FFT ANALYZER

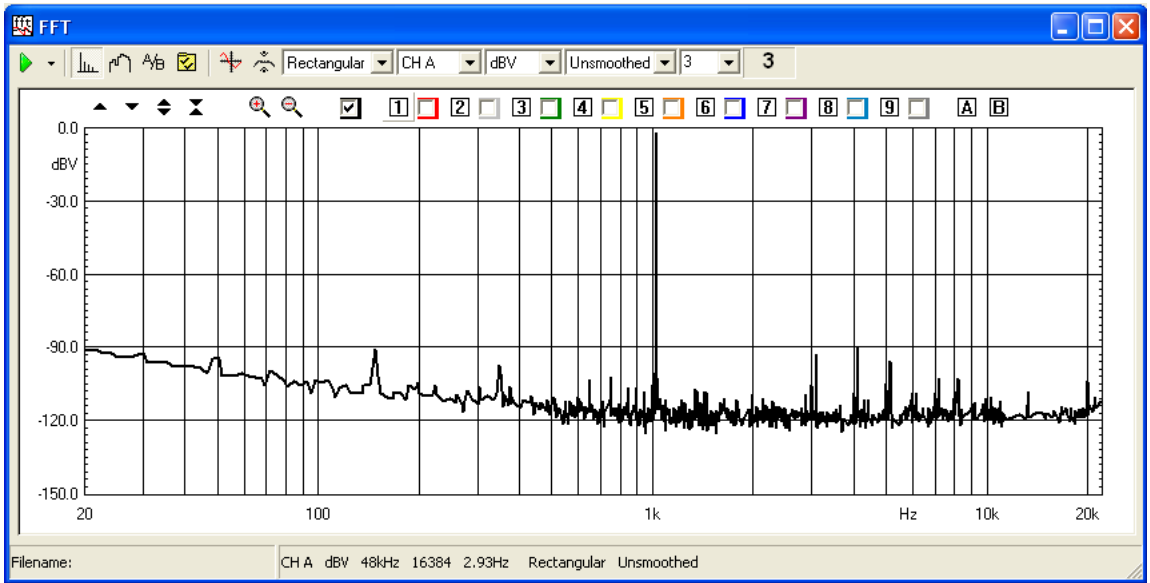









Fig. 9.1 The FFT control panel

Pressing the FFT button you select the narrowband FFT analyzer. Fig. 9.1 shows the FFT control panel (while processing a sinusoidal input signal). The narrowband FFT analyzer is a general purpose instrument that can be applied to the frequency and time analysis of any kind of electroacoustical signal.

There now follows a description of the FFT control panel toolbar and settings.

For a detailed description of the graphical display (common also to other measurement control panels) and its capabilities please refer to Chapter 6. For a description of the available shortcuts please refer to section 4.5.2.

9.2.1 TOOLBAR BUTTONS, DROP DOWN LISTS AND DISPLAYS

-  Starts an FFT measurement. Right-clicking on it you open the associated drop down menu where it is possible to select the **Continue** switch. In this mode the measurement is not started from blank but accumulates with the previously stopped one; see Averaging (9.6) for details.
-  Stops the current measurement.
-  Enters the FFT Settings dialog box.
-  Enables the Time Data display. The second graph that is activated behaves as an **oscilloscope** and displays the captured waveform correspondant to the last FFT analysis.
-  Enables the Hold function. Depending on the setting entered in the FFT Settings dialog box, it is possible to hold either the minimum or maximum value per frequency point.
-  Moves the equal loudness curve up of 1phon. See also 9.5.
-  Moves the equal loudness curve down of 1phon. See also 9.5.

data window

Selects a weighting data window among the following:

- Rectangular (no window)
- Hanning
- Hamming
- Blackman
- Bartlett (triangular)
- FlatTop

channel display

Selects the input channel to display among the following:

- Channel A only
- Channel B only
- Channel BAL (two channels used in balanced configuration)
- Channel A&B (both channels displayed in different graphs)

Y scale units

Selects the measurement units among the following:

- dBV
- dBu
- dBRel (with respect to the global reference level; see chapter 8)
- dB SPL (for acoustical measurements)

frequency smoothing

Selects the frequency smoothing in fractions of octave from 1/48 to 1/2 of octave.

target averages

Inputs the total number of averages. Averaging is controlled by the setting in the FFT Settings dialog; see Averaging (9.6) for details.

number of averages display

Displays the number of the actual average; this number increases during the measurement unless, while in exponential averaging, the target has already been reached; see Averaging (9.6) for details.

9.3 RTA - OCTAVE BANDS ANALYZER

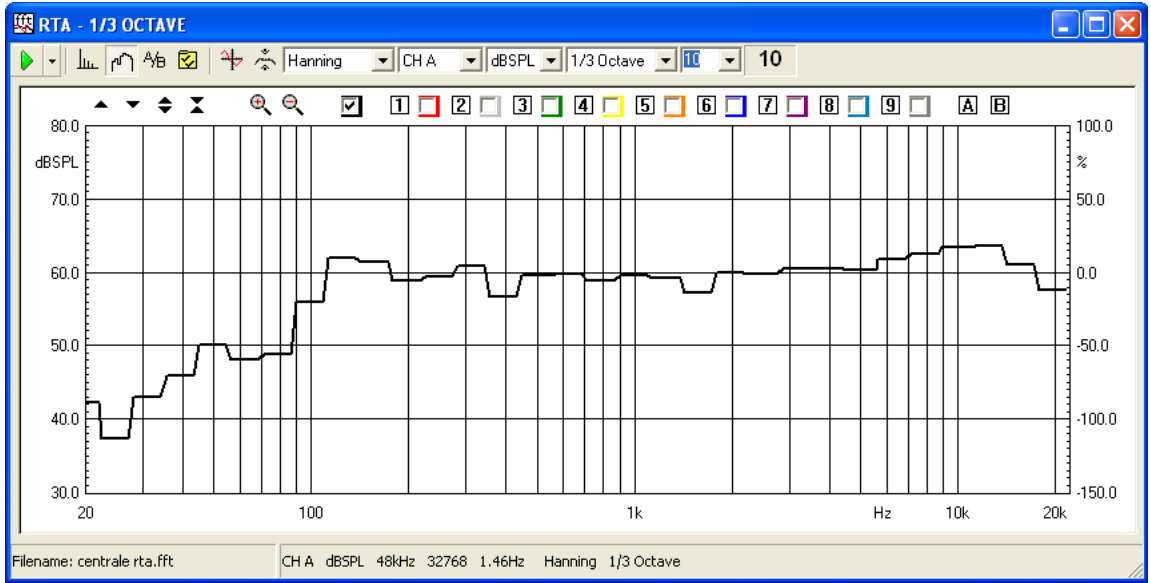


Fig. 9.2 The RTA control panel

Pressing the RTA button you select the octave bands analyzer. Fig. 9.2 shows the RTA control panel (while analyzing the 1/3 octave response of a HT center channel speaker). The RTA (RT stands for real-time) analyzer is a dedicated instrument that is normally used to measure the averaged frequency content of an acoustical signal and for evaluating how a complete reproduction system (from PA to HT) behaves in a real environment.

For a detailed description of the graphical display (common also to other measurement control panels) and its capabilities please refer to Chapter 7. For a description of the available shortcuts please refer to section 5.5.2.

9.3.1 DEDICATED TOOLBAR FUNCTIONS

fraction of octave

Selects between 1/3 and 1/6 of octave analysis.

This is the only different toolbar function from the FFT narrowband case; for all the other functions refer to 9.2.1.

9.4 FFT SETTINGS DIALOG

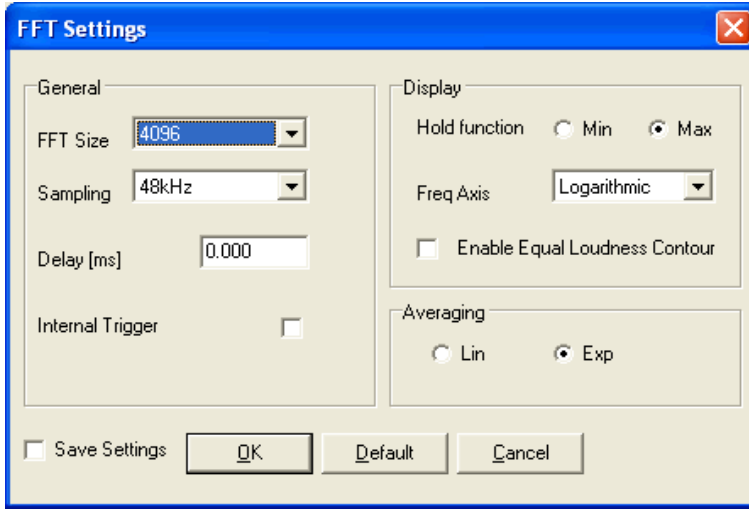


Fig. 9.2 The FFT settings dialog box

FFT Size

Selects the number of samples acquired and processed by each FFT. It is possible to choose a size between 512 and 131072 points.

Sampling

Selects the sampling frequency.

Delay

Permits the input of the desired processing delay (in ms) when in Internal Trigger mode. See 9.7 for details.

Internal Trigger

Enables the Internal Trigger mode. See 9.4 for details.

Enable Frequency Calibration

Enables frequency calibration to compensate for any hardware non linearity; frequency calibration, if enabled, takes place only when the generator is active.

Hold Function

Selects either Min or Max hold function. This functionality is activated by the relative toolbar button.

Freq Axis

Selects from linear or logarithmic frequency axis (valid only for FFT narrowband)

Enable Equal Loudness Contour

Enables the display of the normal equal loudness level curves as defined in the ISO 226 standard. The curves are displayed only in FFT narrowband and RTA modes when dB SPL units are selected.

Averaging

Selects either linear or logarithmic averaging; see Averaging (9.6) for details.

9.5 FFT AND RTA OPERATION

The FFT and RTA measurements (and also Multi-meter ones, see Chapter 8) differ from MLS and Sinusoidal ones in the fact that they are interactive; the user has control over measurement time and generated stimuli. You may also obtain answers about unknown signals from them, without any need for generating a stimulus; or you may leave this job to others, similar to when you measure an audio chain relying on the test signals contained in a CD-ROM. One effect of this is that, strictly speaking, FFT measurements may lead to less precise results if compared to other techniques; the possibility of injecting a synchronous MLS sequence at the beginning of the same audio chain mentioned before is surely a better approach even if, in the vast majority of cases, unfeasible.

FFT and RTA power depends not only on the measurements settings themselves but also on the **generated signals**. Please refer to chapter 7 for a detailed description of the signal generator and its many capabilities.

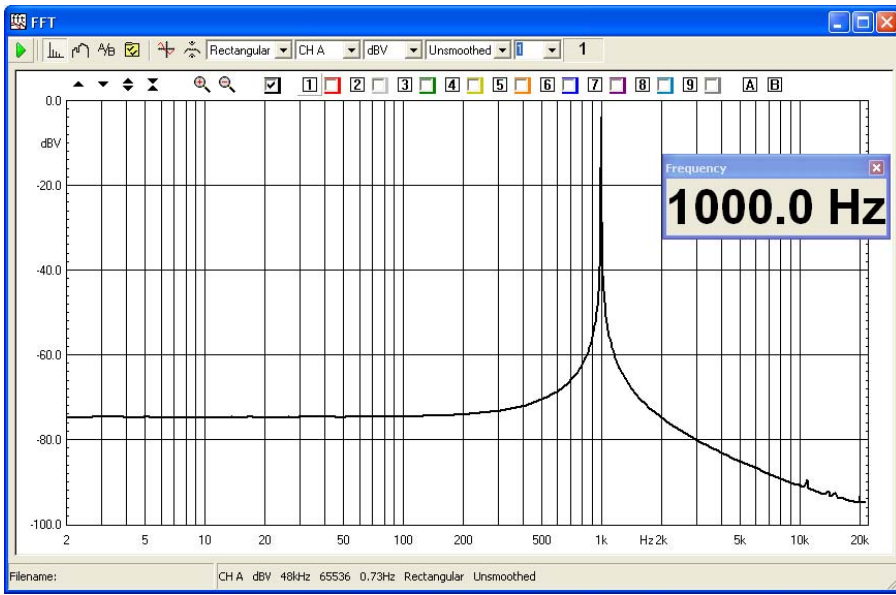
When stimulating any external device with CLIO (see 4.8.2 and 4.8.3 for basic connections) you may choose a limited bandwidth signal (like a single sinusoid) or a wide bandwidth signal as a noise; in the first case you have the possibility of analyzing the harmonic content of the output spectrum while in the second case you may evaluate the frequency response of the device under test. A different stimulus, about halfway between the two cases just mentioned, is a logarithmic chirp swept across some octaves (like a chirp covering four octaves from 50 to 800Hz); in this case you are able to analyze both the response plus unwanted effects like distortion and noise produced by the D.U.T..

When using the FFT narrowband analyzer it is possible to achieve a flat response of the analyzing chain using white noise or similar signals whose energy content varies **linearly with frequency**; among these MLS, All-tones signals or linear Chirps.

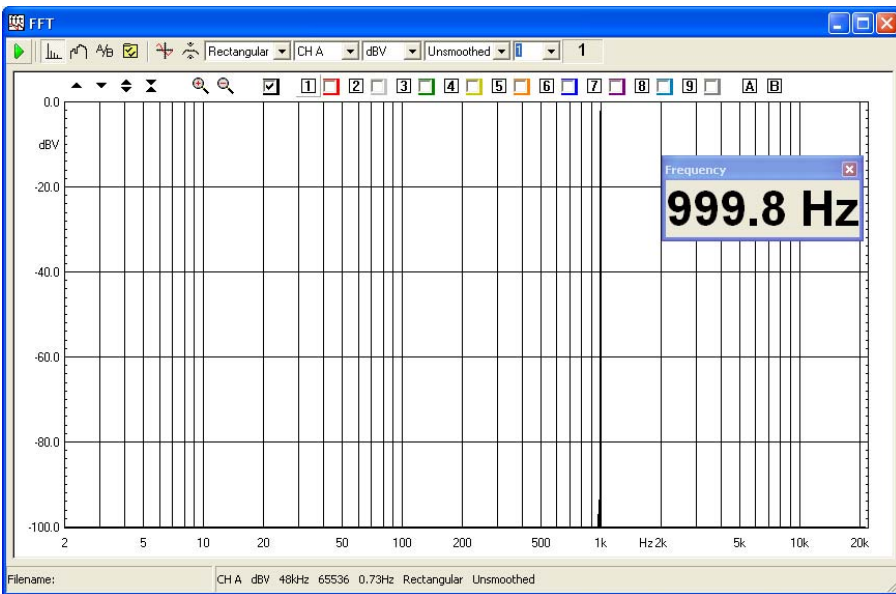
When using the RTA octave bands analyzer it is possible to achieve a flat response of the analyzing chain using a signal whose energy content varies **logarithmically with frequency**; among these we find pink noises or logarithmic Chirps.

Besides the choice of the stimulus it is very important to achieve proper **synchronization** between the generated signal and the acquisition; this will lead to optimum performances avoiding the use of data windows and minimizing any spectral leakage that may occur. Synchronization can be achieved defining the stimulus in a particular manner or by means of proper triggering (see later **internal trigger**).

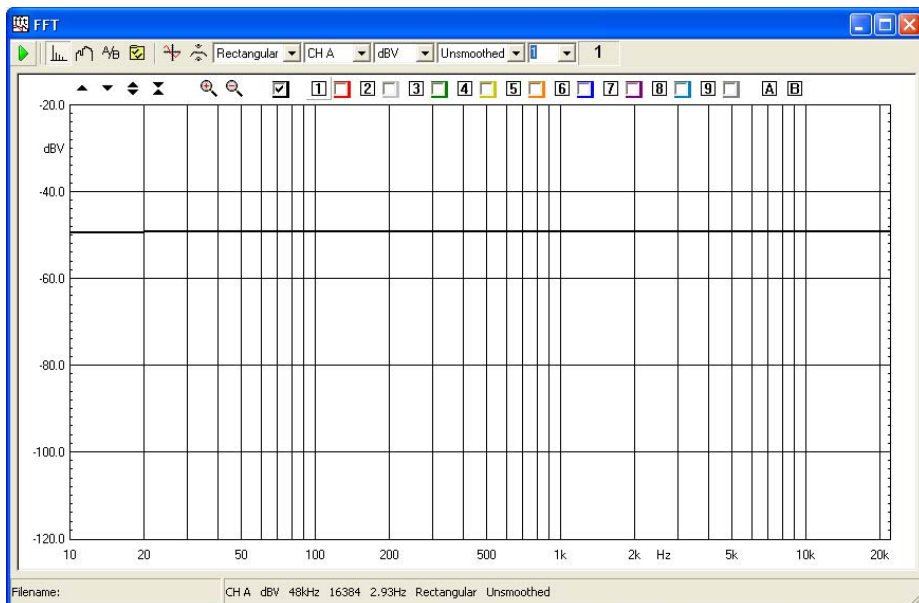
If you are generating a **sinusoid** choose a frequency that is an integer multiple of the frequency **bin** (i.e. sampling frequency divided FFT size) or let CLIO calculate it setting "FFT bin round" in the generator input form (see chapter 7). As an example we would like to play and analyze a 1kHz sinusoid using a 64k FFT @ 48000Hz sampling; the frequency bin associated is 0.73Hz and the nearest spectral line to 1kHz is the 1365th one at 999.75Hz. If you simply generate a 1kHz sinusoid without rounding it to the nearest bin you obtain the analysis of fig. where it is evident that CLIO is capable of outputting a highly precise 1000.0Hz sinusoid but it is also evident the spectral leakage caused by this choice.



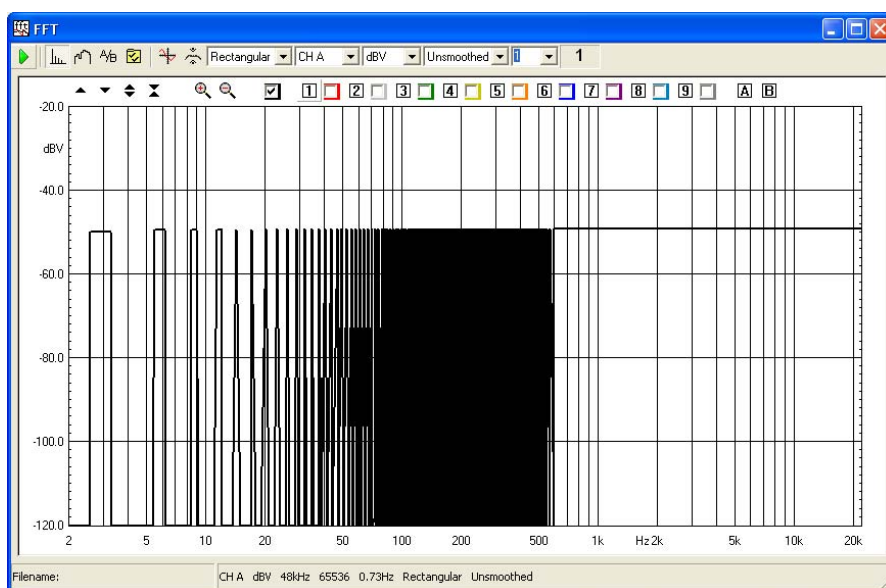
A better approach is to center the sinusoid to the nearest spectral line i.e. 999.75Hz as shown in the next figure. Note the use of the multimeter as frequency counter; note also that its precision is of 0.1Hz when FFT size is higher than 32k.



If you want to generate a full spectrum signal choose an All-tone of proper length matching FFT size. The following figure shows a 16k All-tone (all16384.sig) analyzed with a 16k FFT.



If you had chosen a wrong size, like an all tone of 8k, you would have obtained the following analysis which clearly shows a lack of energy at alternating bins; the effect is visible only at low frequency due to the logarithmic nature of the graph.



CLIOwin has the possibility of **internal trigger** (and relative **delay**) i.e. triggering with respect of the generated signal thus obtaining a synchronous capture. As an example let's see how a measurement presented in section 11.4 was done; please refer to figures 11.9, 11.10 and 11.11. We have an acoustical measurement of a tweeter, done stimulating it with a 2kHz 10ms tone burst (see 5.4.2 for details about programming a bursted sinusoid); the FFT measurement is done using the internal trigger; Fig. 11.9 shows the analysis and the captured time data that clearly shows the flight time from the tweeter to the microphone, Fig. 11.9, Even if the analysis is not our final target, it shows the power of synchronous acquisition which permits the display of the arrival delay of sound to the microphone. To obtain the desired result, as explained in 11.4, it is necessary to remove the flight time plus the device settling time; this can be easily accomplished setting the internal trigger delay, in FFT settings, to 1.5ms; the final result shown is shown in 11.11 and permits the identification of the device harmonic distortion.

To proceed further one could vary the stimulus amplitude and test the distortion of the tweeter at different amplitudes; using bursts also prevents the damage of the unit as the overall power delivered to it rather low and a direct function of the duty cycle of the burst itself.

The main application of RTA analysis is in assessing the quality of an audio installation (from the placement of the speakers in a listening room to the overall sound quality of a car stereo system). In these cases pink noise is often used as the stimulus. If you are not using CLIO as the source of such a stimulus be sure to use a good one; you may find several audio generators that do the job, but they are usually expensive. A good choice is to use a recorded track of one of the various test CDs available; in this case not all the CD-ROM readers may furnish adequate results, as appears from the graph in Fig. 9.3

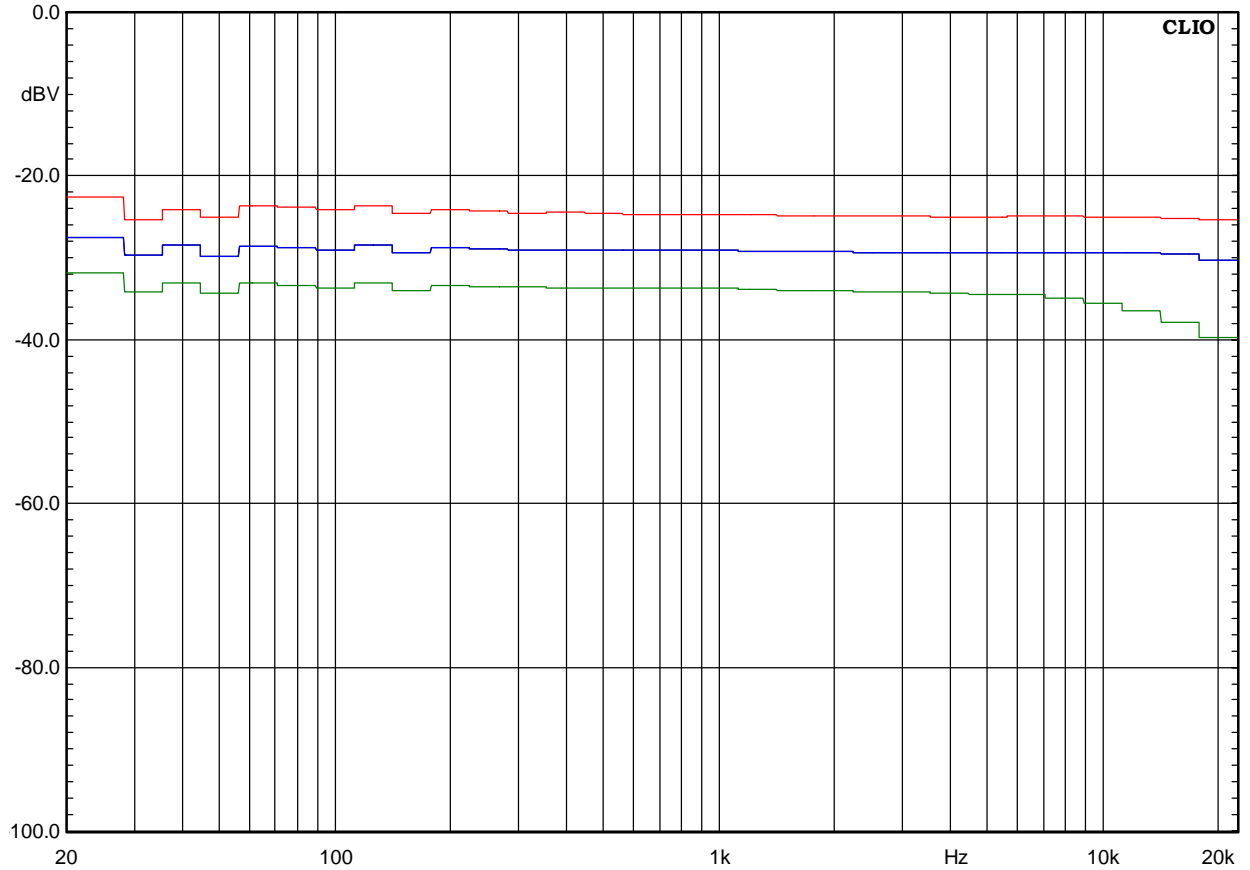


Figure 9.3

All three graphs represent true analog pink noise, they are played at intervals of 5dB for clarity. The upper (red) is the output of an Audio Precision System One generator; the second (blue) is the pink noise of track 4 of the Stereophile Test CD played by a Philips CD692 CD player, the third is the same track of the same test CD output by the computer which I'm writing with right now (Pioneer DVD Player plus Crystal Sound Fusion PCI Audio).

When taking RTA measurements use, at least, 16k FFT size if you want to cover the entire 20-20kHz audio band; using lower sizes results in octave bands not present as no FFT bins fall inside them.

9.6 AVERAGING

Averaging plays a very important role in FFT analysis. It is vital when analyzing signals buried with noise. It is also important when taking spatially averaged measurements. CLIOwin has flexible averaging capabilities. Averaging basically means adding and dividing for the number of additions made. To start an averaged FFT measurement you need to set a number bigger than one in the Target Average drop down; otherwise you have a continuously refreshing single measurement that will continue until the Stop button is pressed. It is possible to choose between **linear** and **exponential** averaging. The instrument behaves differently in the two averaging modes. In linear averaging the measurement is continued until the target is reached, then it automatically stops. What you get is exactly what we have just explained. In exponential averaging the measurement never stops. When the target is reached the averaging continues relying on a mathematical formula which discards the oldest acquisitions and gives more and more importance to newer ones. The exponential averaging is the default one.

As an example Fig. 9.4 compares a single 1kHz sinusoid FFT analysis with a 100 averages one.

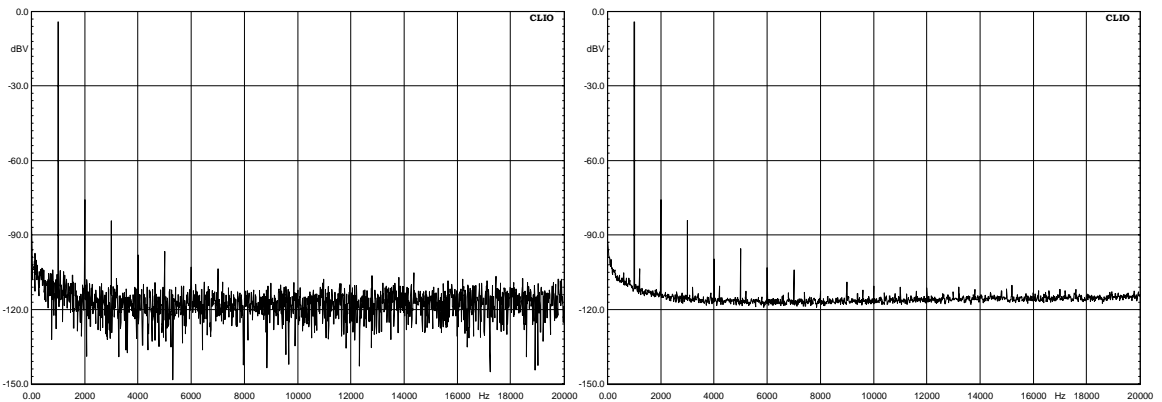


Figure 9.4

This is a classical example of signal buried with noise: the sinusoid's 9th harmonic is clearly visible after 100 averages, but invisible for a single acquisition.

Another important feature, when averaging, is the possibility of **continuing** averaging after a measurement is stopped, has reached its target or a previous measurement has been loaded from disk. CLIOwin has this capability when selecting «continue» in the drop down menu available beside the Go button (Fig.9.5).

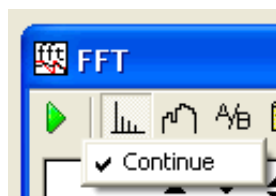


Figure 9.5

Selecting the continue option allows for example, for spatially averaged measurements. Fig. 9.6 shows two 1/3 octave RTA measurements of a small HT satellite at listening position: the black one is a single 10 averages measurement taken on axis; the red one is, instead, built using the continue option, adding a total of eleven 10 averages measurements taken moving from -25 degrees left to +25 right of the speaker itself.

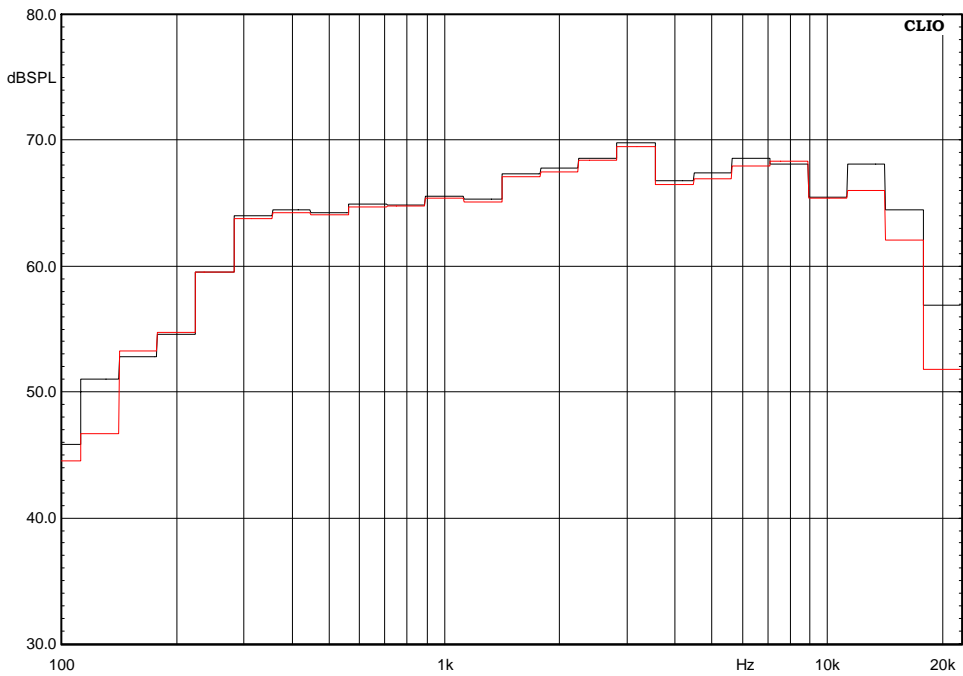


Figure 9.6

9.7 TIME DATA DISPLAY (OSCILLOSCOPE)

The time data (Fig. 9.7) is an ancillary display to an FFT or RTA executed measurement. Here we see a 100Hz sinusoid captured and analyzed with a 16K FFT.

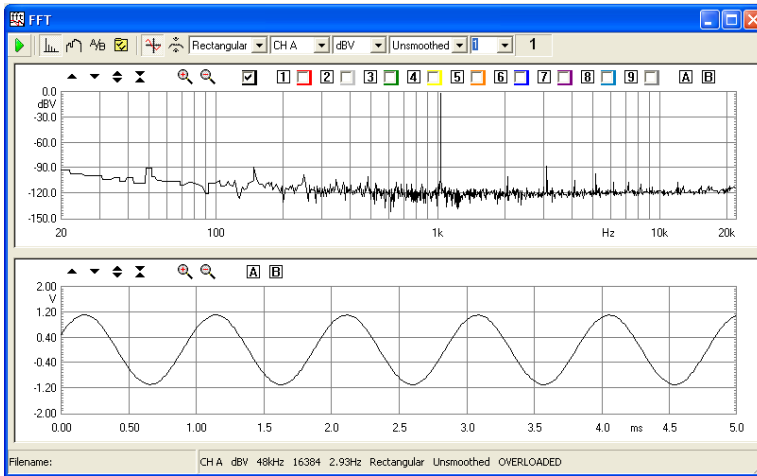


Figure 9.7

The time data display has a number of particular features that allow, **out of user control**, for automatic scale adjustment and triggering of the displayed signal.

The time information displayed is the processed data only. The user can zoom in and out of this data but it is not possible to display more than one acquisition area. Fig. 9.8 shows this effect; the same 100Hz sinusoid as before seems now truncated; this means that we only reached the maximum displayable data, in case of a 16K FFT @ 51200Hz sampling this is exactly 320ms.

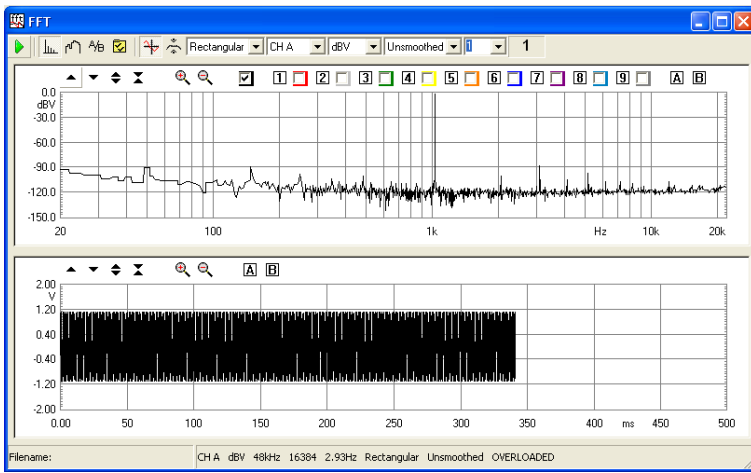


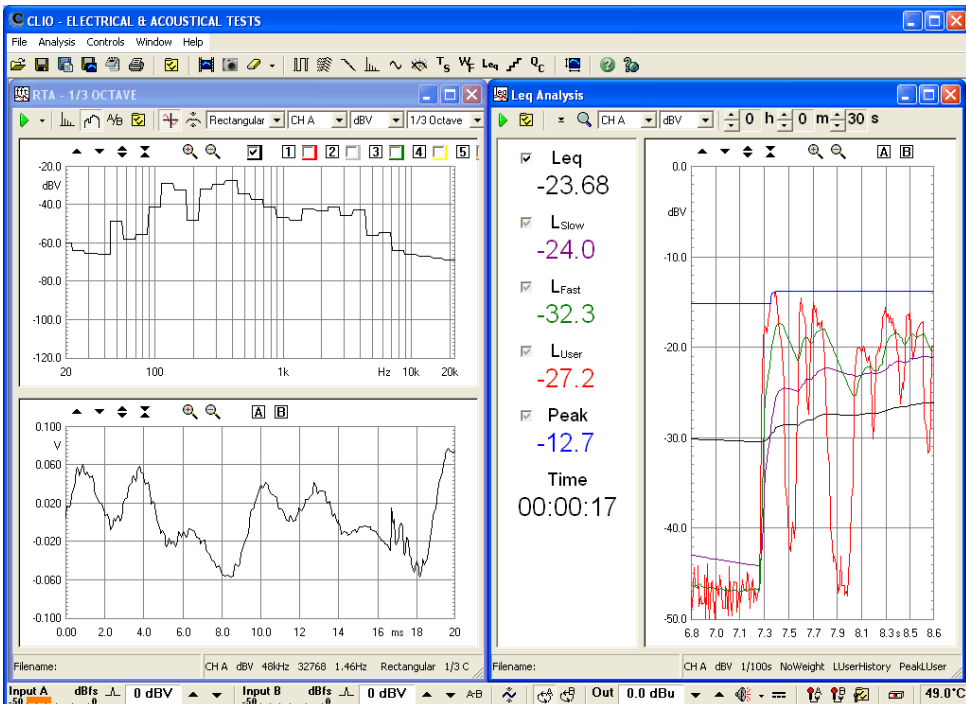
Figure 9.8

9.8 FFT AND MULTI-METER

There is a close interaction between FFT and Multi-meter operations. The two measurements share the same acquisition and processing core. Should they operate together the FFT control panel acts as the **master** while Multi-meter follows as the **slave**. In this situation, among other peculiarities, the Go and Stop buttons of the Multi-meter are disabled; if an FFT acquisition is started then the Multi-meter runs as well, the same when you stop the measurement. More on this is in section 8.6.

9.9 FFT AND Leq ANALIZER

It is possible to execute FFT or RTA analysis while an Leq measurement is taking place. The following figure shows the analysis of a sample of speech done with Leq and RTA in parallel.



Some limitations apply to FFT settings, in particular it is not possible to select an FFT size higher than 32768. See also chapter 16.

9.10 "LIVE" TRANSFER FUNCTION ANALYZER



Fig. 9.3 The Live transfer function control panel

Pressing the Live transfer function button the instrument behaves as a dual channel FFT analyzer referencing one channel to the other and calculating the transfer function between the two. Fig. 9.3 shows the Live transfer function control panel (while measuring the frequency and phase response of a loudspeaker). The Live transfer function analyzer is the fastest way to measure frequency response and has been optimized for interactive and fast refreshing live situations when the only available signal is reproduced music.

For a detailed description of the graphical display (common also to other measurement control panels) and its capabilities please refer to Chapter 7. For a description of the available shortcuts please refer to section 5.5.2.

9.10.1 DEDICATED 'LIVE' TOOLBAR FUNCTIONS

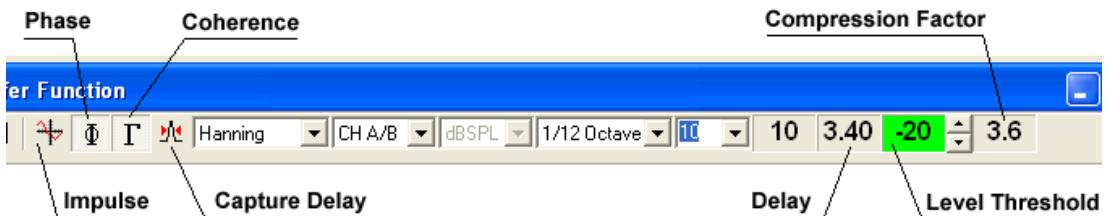






Fig. 9.4 The Live transfer function toolbar

-  Enables the Time Data display. The lower graph displayed is the **impulse response**.
-  Enables **phase** response to be displayed in the lower graph.
-  Enables **coherence** response. The coherence is displayed in the same graph of the transfer function magnitude and reads on the right displays scale.
-  Automatically evaluates the interchannel delay and sets it. The value of the delay is shown in the delay display.

delay display

Shows the delay correction, in ms, that is applied while processing the two channels.

level threshold display and control

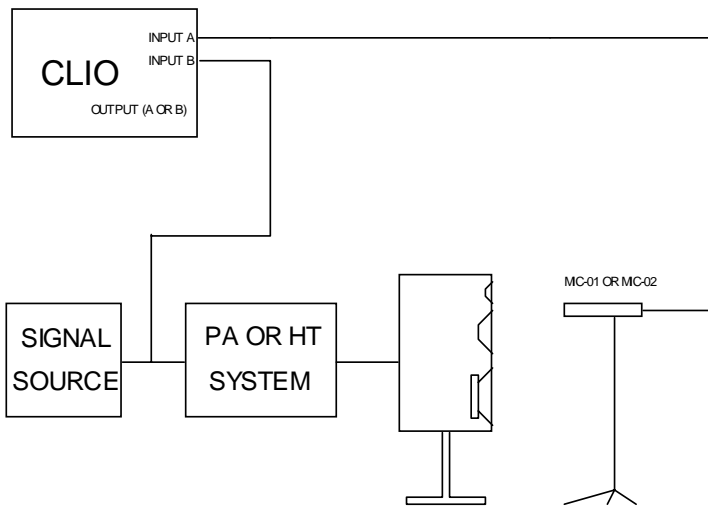
Sets the peak level versus input full scale of the reference channel below which the measurement is frozen. It is possible to modify the value using the dedicated spin buttons. Setting this threshold properly lets you measure only when the signal is present at the reference channel and avoid that inaccurate readings accumulates with the measure distorting it.

compression factor display

Shows the difference, in dB, between the crest factors of the two input signals. The compression factor gives you a rough indication about how much the system under test is limited in its dynamic range. The more negative the compression factor more the system is limiting the input signal.

9.10.2 USING CLIO DURING A LIVE PERFORMANCE

When using CLIO as a dual channel FFT analyzer for measuring a “Live” transfer function you should follow a particular connection diagram which is depicted in figure.



In this case the signal source may be music or any live program material; to monitor the system transfer function you must feed the original signal plus the measured one to CLIO. The input channel to which you connect the original signal is said to be the **reference** channel; in figure it is channel B; you will then measure the A/B transfer function.

Before starting a live measurement choose the proper FFT settings based on your experience; for your first tests we suggest the following:

- FFT Size: 32k or more
- Window: Hanning
- Smoothing: 1/48th Octave
- Averages: at least 10
- Level Threshold: -20dB.

Another factor of maximum importance in order to obtain the best results is to properly set input sensitivity for **both** input channels **separately**; the two peak meters of CLIOwin desktop should help you in this task; set input sensitivity so that both readings average in their respective green areas. If you are taking as reference the line level signal fed to the sound reinforcement system and are measuring from a microphone it is quite common the situation in the following figure where the two input channels have sensitivity which differ of 40dB or more.

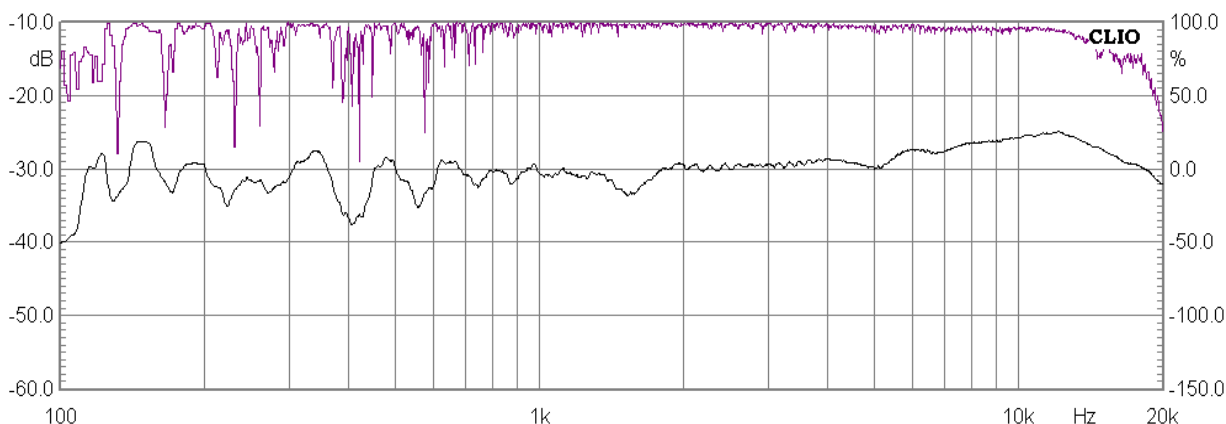


When the measurement is started you will see the A/B **magnitude** frequency response which is averaging on the screen and fast refreshing; sometimes you may notice, in dependence of moments when sound is particularly low or absent, that the measurement freezes and the Level Threshold display becomes red:



You may freely choose the most appropriate level threshold so that your measurement accumulates only when signal is present; take into consideration that the threshold relates to peak level vs. full input scale so it is not an absolute value but can be directly compared with the CLIOwin desktop peak meters.

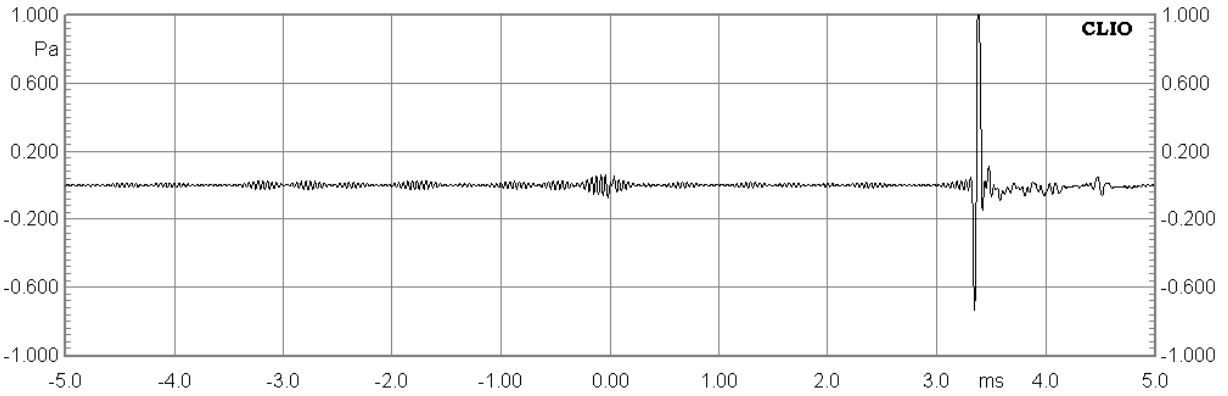
Another important indication about how good is your measurement is given by the **coherence** graph.



The coherence function tells us in which frequency zones the energy content of the measured signal relates, i.e. is coherent, with the reference signal; the more the signals are coherent the more the coherence function approximates unity (or 100%); the less they are coherent the function tends to zero. In figure above we may say that both in the highest frequencies region (above 15kHz) and in the mid-bass region there are zones of low correlation (<50%) where the measured response should be considered with attention.

Beyond the magnitude frequency response it is also possible to measure the **phase** response and the **impulse** response. When taking acoustical measurements these functions heavily depend on the **interchannel delay** i.e. the total amount of delay present between the two channels, normally due to electronic equipment, misalignment of sound sources or flight time from speakers to microphone.

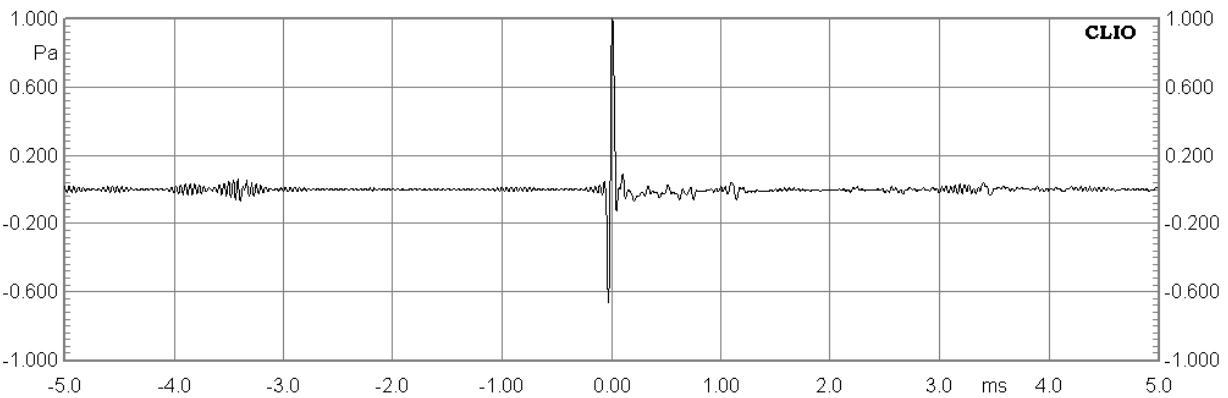
When the measurement is just started, if you select the Time data display, you may see the following impulse response.



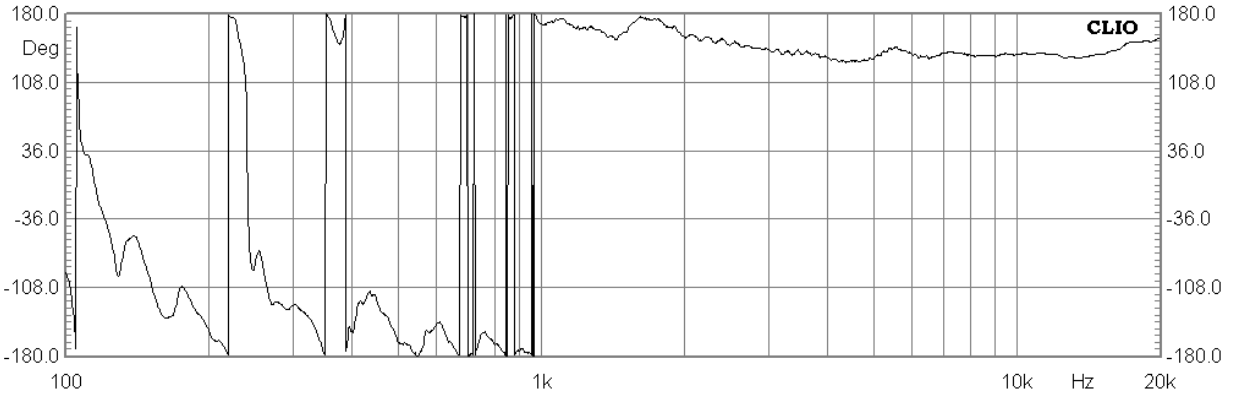
The interchannel delay is of about 3.4ms; if you want to measure the phase response of the system properly you should try to remove it. You can do this in several manners:

- 1) **Press the Capture delay button**; the software should calculate and automatically remove the delay setting it; you should see the captured delay in the delay display.
- 2) Try to input the delay value manually; you can do this **clicking on the delay display** and entering the desired value in the resulting dialog.
- 3) Modify the delay interactively with the keyboard using the **PgUp**, **PgDn** (0.1ms steps) or **Shift-PgUp** and **Shift-PgDn** (1 sample steps) keystrokes.

At the end of this process the impulse will be located around zero time.



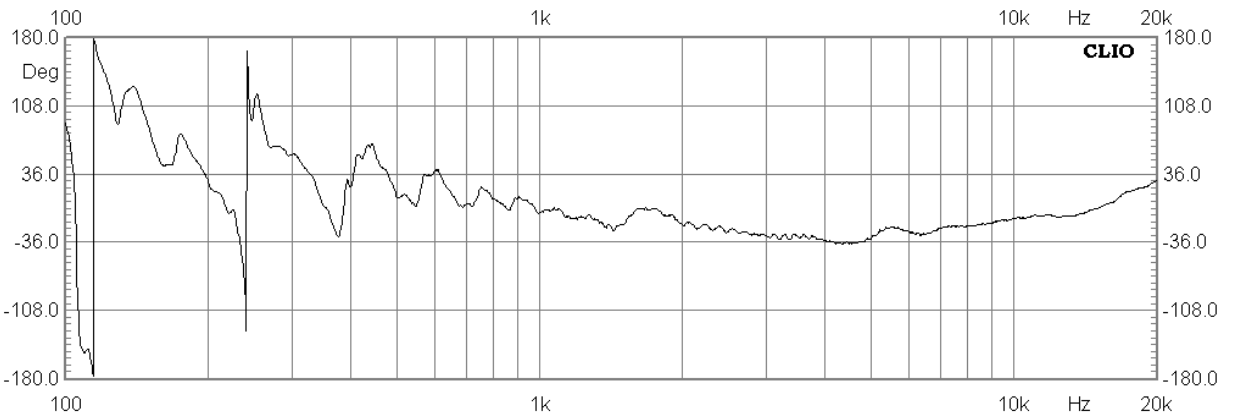
The last obstacle you may find while measuring phase is that, even if the interchannel delay has been correctly removed, still remains a phase inversion in the chain giving the following response.



It is possible to control a phase inversion with the dedicated buttons on CLIOwin desktop; simply invert the phase of either channel A or B, obviously not both!



In this way the final measurement of phase response will be as follow.



10 MLS & LOG CHIRP

10.1 INTRODUCTION

Within this menu two different technique are available that yields to the final result, the complex transfer function of a generic device. They are MLS and LOG CHIRP Analysis. While the internal processing is quite different the result is the same and this justify keeping them together. Advantages of each approach will be described later in this chapter briefly, leaving to the bibliography for details.

MLS stands for Maximum Length Sequences, is a powerful well established technique that allows you to carry out analysis of linear systems recovering the **Impulse Response** of the device using a fast cross-correlation algorithm . It is therefore a Time based analysis. Frequency domain information is obtained calculating the Fast Fourier Transform, hereafter FFT, of the impulse response.

LOG CHIRP analysis uses a log-swept sine chirp as stimuli. The Frequency Response is obtained with a deconvolution process and the impulse response with an Inverse FFT of the Frequency Response

Both approaches carry a crucial piece of information in the time domain, the **Impulse Response**. MLS & LOG CHIRP is therefore particularly well suited for recovering the anechoic sound pressure response of a loudspeaker. i.e. the frequency response of a loudspeaker as if it where positioned in an anechoic room, while carrying out the measurement in a normal room. Just as importantly MLS & LOG CHIRP allows complete evaluation of room acoustic parameters.

Within this Menu the user will be able to switch from time domain to frequency domain and back using the powerful post processing tools CLIO provides. This allows the collection of very sophisticated and complete information of any electro-acoustic device. Both the theory behind all of this and the amount of parameters that affect the measurement results make this Menu probably the most complicate to use. We will skip the theory completely and after a concise description of the whole User interface we will deal with real life applications.

10.2 MLS & LOG CHIRP CONTROL PANEL

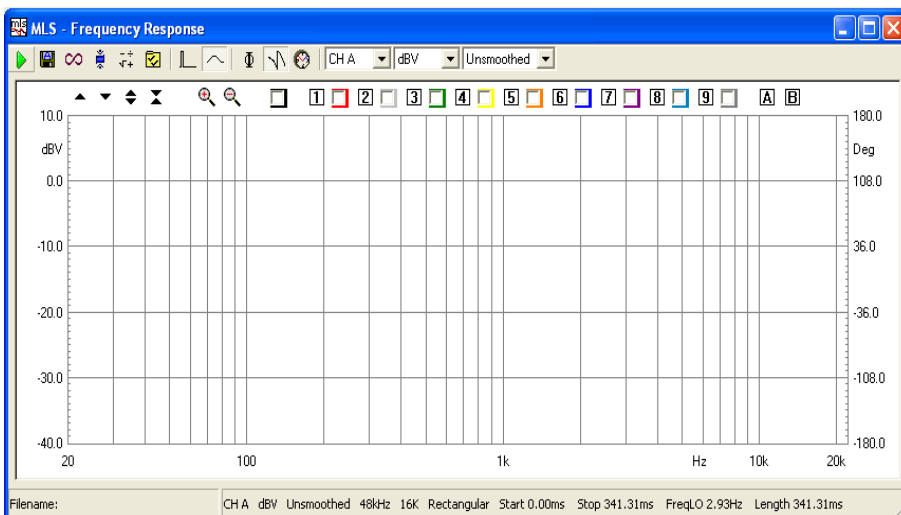





Figure 10.1

10.2.1 TOOLBAR BUTTONS

 Starts an MLS & LOG CHIRP measurement.

 If pressed the measurements will be autosaved. The current autosave definitions apply; see 6.3.1 for details.

 Selects the Loop mode. When in Loop mode the MLS & LOG CHIRP measurement is automatically repeated until the user presses a keystroke or releases the button. If Autosave is active the loop mode ends after the total files to be autosaved are done.

 When an MLS & LOG CHIRP measurement is taken, it automatically applies the selected post-process.


 Enters the MLS & LOG CHIRP Process dialog box.

 Enters the MLS & LOG CHIRP settings dialog box.



 Enters Time domain.

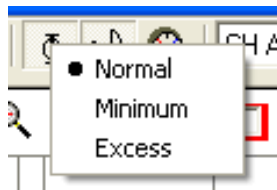
 Enters Frequency domain.

 Displays phase.

 Set wrapped or unwrapped phase

 Displays group delay.

By right clicking either on phase  or group delay  button the kind of calculation can be selected:



Normal displays the measured phase (group delay) curve referring to the selected time domain data.

Minimum calculates and displays the phase (group delay) curve, related to the current modulus curve, in the assumption of minimum phase behaviour (i.e. the Hilbert transform of the log magnitude).

Excess calculates and displays the phase (group delay) curve as the difference between the Normal and the Minimum ones.

10.2.2 TOOLBAR DROP DOWN LISTS

input channel

Selects the input channel configuration.

Y scale unit

Selects the measurement units. It is possible to select Voltage (dBV, dBu, dBRel) or Pressure (dBSPL) or Impedance (Ohm).

smoothing

Activates a frequency smoothing of the active curve. This smoothing effect will allow a better appreciation of the general features of the response curve. The smoothing algorithm that is employed averages all values within a fraction-of-octave band surrounding each analysis frequency.

10.2.3 MLS & LOG CHIRP SETTINGS DIALOG

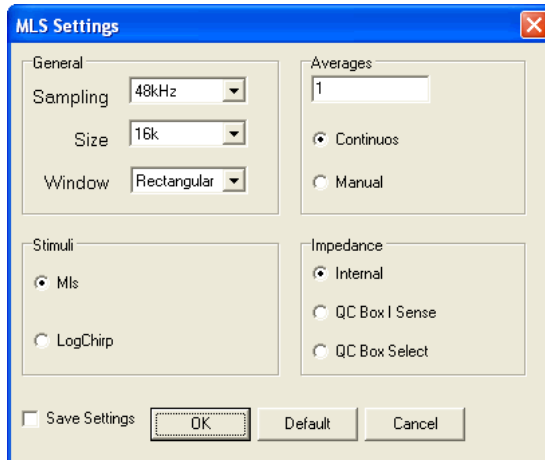


Figure 10.2

sampling

Selects the measurement sampling frequency. When LOG CHIRP is selected as stimuli, 48kHz only is available.

size

Selects the size of the MLS & LOG CHIRP sequence.

window

Selects the appropriate kind of window for analyzing time data. It is possible to select between a rectangular, Hanning or Blackman window; the last two can be **full** or **half sized**. NOTE: These windows are applied to the time portion to be transformed with FFT. If the start point is near the impulse, **full windows** will null the most important part of the time response (due to their rise time). To evaluate the effects of a data window refer to Chapter 9, and FFT measurements in general.

stimuli

Selects the kind of stimulus, either MLS and LOG CHIRP used for the measurement.

averages

Controls the averaging mode of operation. The measurement will be repeated and averaged the number of times set, therefore obtaining a better signal-to-noise ratio at the expense of reduced measurement speed. **Continuous** performs the number of averages in the shortest time without waiting. **Manual** waits the user to press any key between each measure; it is useful, for example, in averaging different microphone positions.

impedance

Set how Impedance is calculated. When taking impedance measurements refer either to the **internal** impedance mode or to the **ISense** feature of the CLIOQC

Amplifier & SwitchBox Model 2,3 and 4. If **QC Box Select** is selected the hardware setting of the QC Box determines directly the Impedance Mode (please refer to chap. 5.5.1)

10.2.4 MLS & LOG CHIRP POST-PROCESSING TOOLS

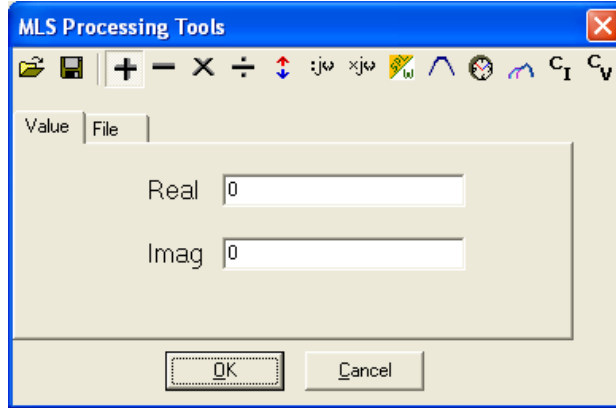















Figure 10.3

-  Loads an MLS & LOG CHIRP process.
-  Saves an MLS & LOG CHIRP process.
-  Adds a data value or compatible file to the current measurement.
-  Subtracts a data value or compatible file to the current measurement.
-  Multiplies the current measurement by a data value or compatible file.
-  Divides the current measurement by a data value or compatible file.
-  Shifts the current measurement by a dB value.
-  Multiplies the current measurement by complex frequency.
-  Divides the current measurement by complex frequency.
-  Uses a reference measurement file taken at speaker terminals to calculate 1m sensitivity in dBSPL/W. The reference file should have dBV Y units while the one in memory should be in dBSPL.
-  Process the current measurement with an octave band filter. It is possible to input the mid-band value and the filter bandwidth.
-  Temporally shifts the current measurement by a ms value. Affects phase response.
-  Merges the current measurement with the part below the selected transition frequency of a selected compatible file.

C_I Combines the actual measurement and the selected file to obtain a constant current impedance measurement. Both files should be in dBV.

C_V Combines the actual measurement and the selected file to obtain a constant voltage impedance measurement. Both files should be in dBV.

10.3 IMPULSE RESPONSE CONTROL PANEL

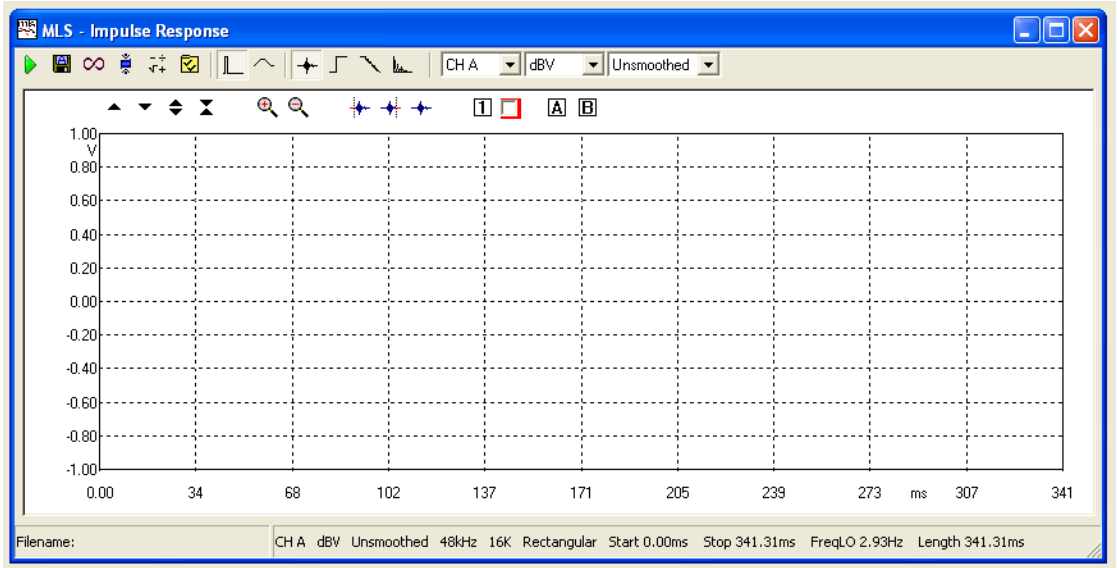


Figure 10.4

10.3.1 TOOLBAR BUTTONS

The following toolbar buttons differ from frequency domain control panel:


 Displays Impulse Response.


 Displays Step Response.


 Displays Schroeder Decay.

 Displays Energy Time Curve (ETC).

Also the following buttons inside the measurement area are particular to this control panel. See Chapter 6 for other general information.

 Selects the starting point of the measurement window.

 Selects the end point of the measurement window.

 Restores the default state of the measurement window thus selecting all the acquired points for analysis.

 Stores and display an overlay curve

  Activates marker A and B

10.4 MEASURING FREQUENCY RESPONSE

In a step by step process we will deal with any single aspect that affects MLS & LOG CHIRP measurement results. At first we deal with electrical measurements, leaving acoustical as the last steps.

10.4.1 MEASUREMENT LEVEL

Opening the MLS & LOG CHIRP menu for the first time you will see a graph which has frequency on its X-axis. Our first step will be measuring the response of an "A" weighting filter. All the settings are left in their default state; we will take care when measuring level only. Please ensure that the device being measured cannot be damaged by the output level chosen for the actual measurement. In this example, the device under test cannot be damaged with an output set to 0dB (-5.21dBV with MLS signal, -2.21dBV with LOG CHIRP). Having ensured a safe level we connect CLIO output A with the device input, CLIO Input A with the device output, then enable input auto-range and click the Go button. As a result we get Fig.10.5

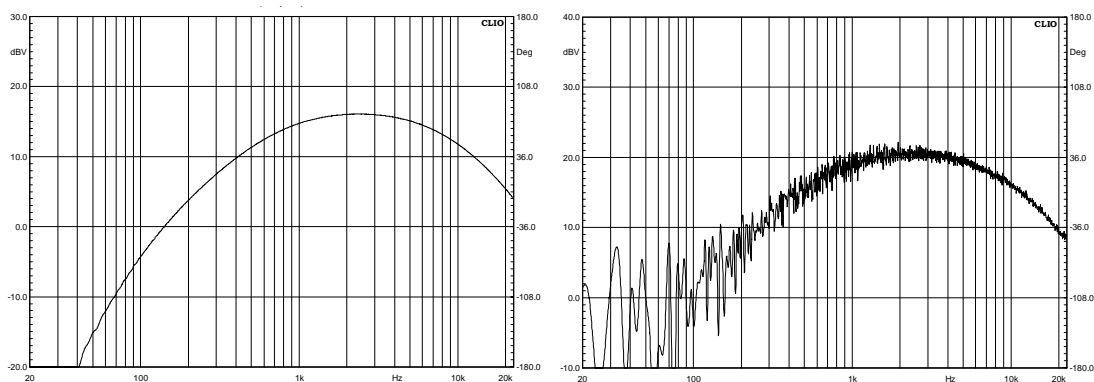


Figure 10.5 and 10.6

The curve reaches 16dBV (6.3V) at 2.5kHz, which is quite a high level for our device. Looking for trouble, we increase CLIO output to +6dB and measure again obtaining Fig.10.6. The device went into saturation; in more emphatic terms it is not linear any more. The whole MLS & LOG CHIRP process works on the assumption the device is linear. If this is not the case, it is not easy for an inexperienced user to understand what is going on just by inspecting the results. Checking the measuring level is important, especially when the gain of the device under test is unknown. You should use the Multi-Meter and the MLS & LOG CHIRP signal to accomplish this.

10.4.2 MLS & LOG CHIRP SIZE

The MLS & LOG CHIRP Size is the number of points that defines the MLS & LOG CHIRP sequence. In terms of generating a digital signal these are the number of samples before the signals is started again from the beginning. CLIO handles MLS & LOG CHIRP sizes from 4k to 256k. These terms are inherited by the computer world and are somewhat imprecise. The real size is the nearest power of 2, the 4k being 4096 points and the 256k 262144 points long (one less! for MLS, exactly this for LOG CHIRP). The first important consequence of setting the MLS & LOG CHIRP size is the length of the Impulse Response recovered which is always as long as the MLS & LOG CHIRP itself. From the users point of view what matters is how long this impulse is in terms of seconds. This in turns also depends on the Sampling Frequency set. It is easily calculated as the size divided by the sampling frequency. The default is 16k and 48000 Hz, that is $16384/48000=0.341$ seconds. We will deal with this in more detail later. For now it is enough to say that CLIO also uses this size for the FFT. This is important as the frequency

resolution you get is calculated as the sampling frequency divided by the FFT size. Again for the default settings this is $48000/16384=2.929$ Hz. This is already a high resolution. However thinking in terms of octave or fractions of an octave, which are the terms of a logarithmic frequency axis, 2.929Hz is around 1/2218 of an octave at 10kHz while is around 1/3 of an octave at 10Hz.

Again an example is better than a thousand words. We will measure a twin T notch filter, probably the most demanding situation for frequency resolution, with two sizes 8k and 64k, and two centre frequencies, 10k and 63Hz. Results are in Fig.10.7.

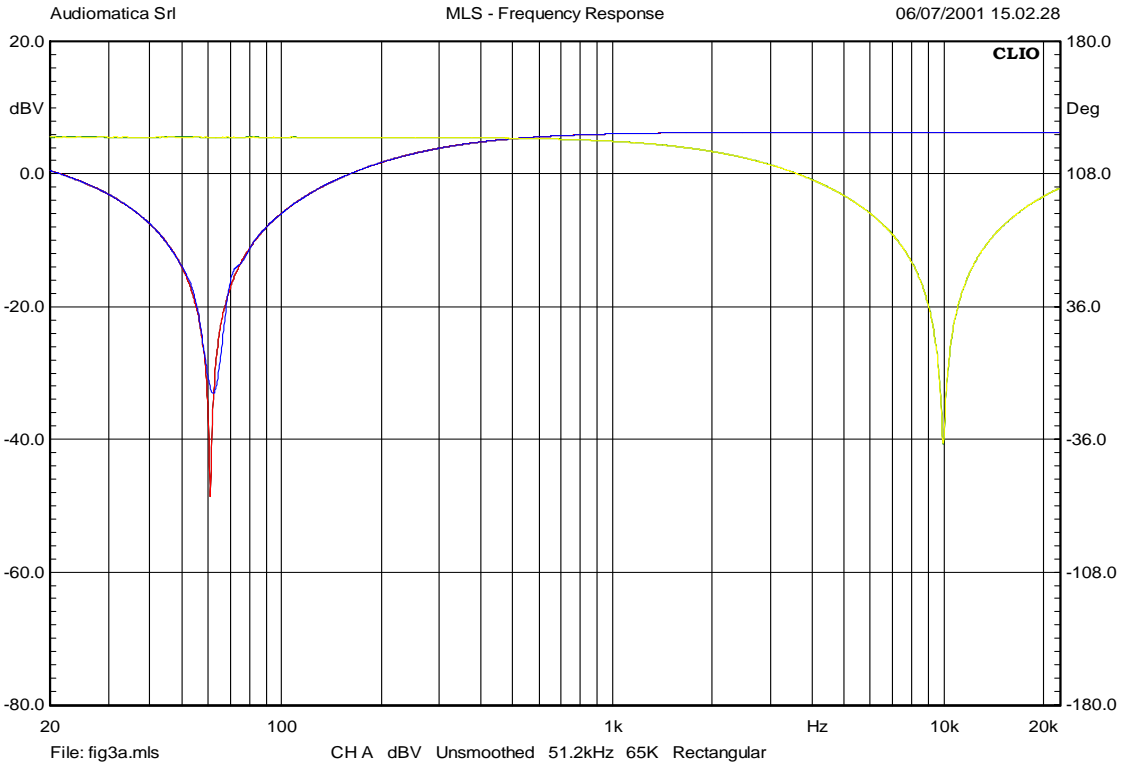


Figure 10.7

Interestingly, while we took four measurements we can only effectively see three curves. In actual fact the 8k size gives by far enough resolution at 10kHz and the associated curve is completely hidden by the 64k one. The 64k curve (Red) only differs from the 8k curve (blue) at 63Hz. We have seen that there is another parameter involved here, which is sampling frequency. While experimenting with it, we will also make our first impedance measurement. We will use CLIO internal mode. This is again the default setting, so all we have to do is to change the Y scale units to Ohms. We are going to measure a big 15" professional woofer using 48kHz and 8kHz leaving the size at 16k. The output level is set at +12dB. Fig.10.8 and 10.9 shows the results.

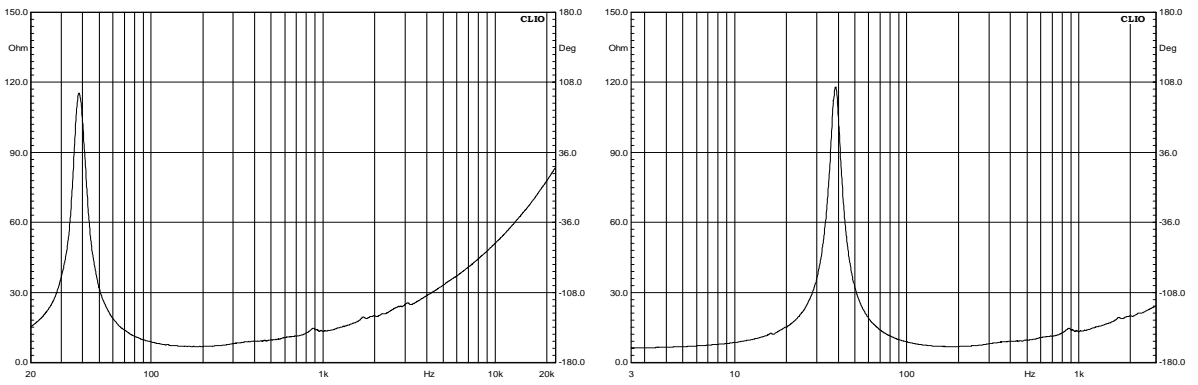


Figure 10.8 and 10.9

The first relevant difference is the frequency range. In the 8kHz sampling rate (Fig 10.9) both sides of the resonance peak are completely visible. Thiele and Small parameters derived with these settings will therefore be more accurate. This is especially true when using the added mass technique, in which case F_s will be lowered even further. But, more importantly, the impedance at F_s , is 115 ohms at 48kHz and 118 ohms at 8kHz.

10.4.3 ACOUSTIC FREQUENCY RESPONSE

Up till now we measured using CLIO and simple cables. Now we are going to deal with acoustic measurements. The time domain will be an essential part of our interest. Furthermore we need to add two external devices, a microphone and a power amplifier. Connections are shown in Fig.10.10.

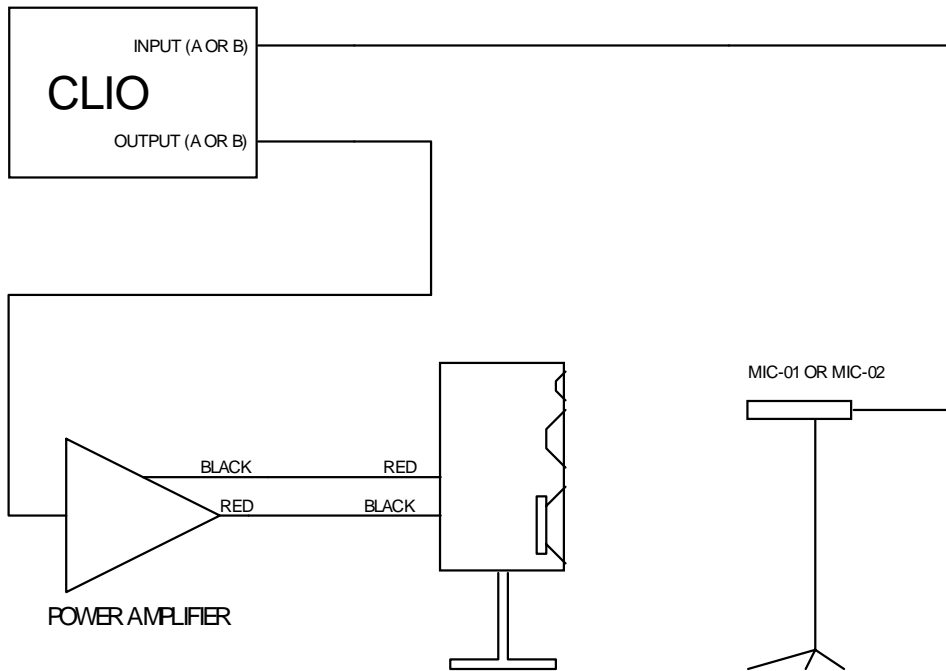


Figure 10.10

Please note that the connections from the amplifier to the speaker are inverting polarity. This is on the assumption that the amplifier is non-inverting, most are so, and you are using Audiomatica Mic-01 or Mic-02, which does invert polarity. Most Measuring Grade Microphones also invert polarity. Remember that inverting polarity does not change the frequency response, however it does change phase response. Fig.10.11 shows how we placed the microphone with respect to the speaker and also with respect to the floor.

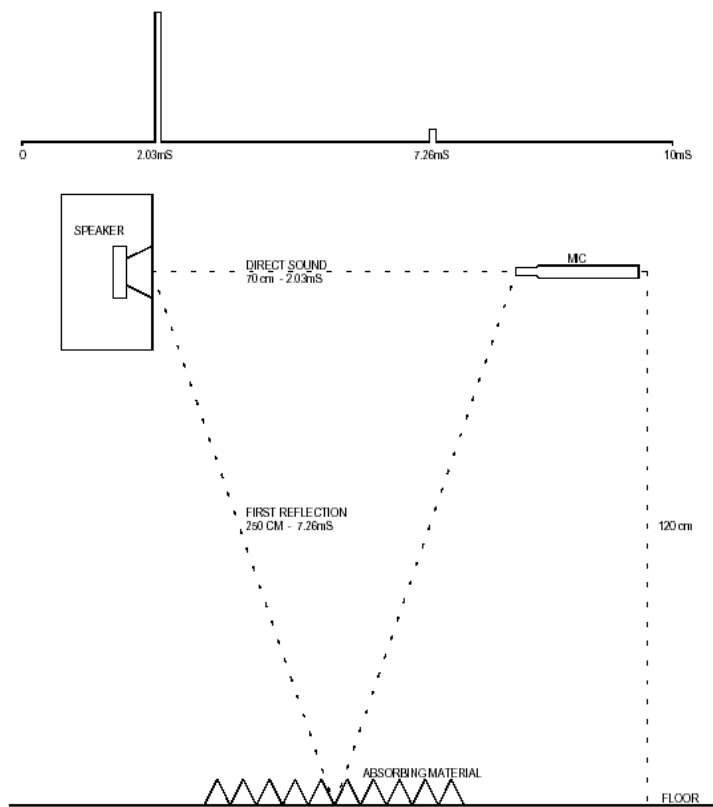


Figure 10.11

Any other reflecting surface is further than the floor. If the microphone is directly connected to the CLIO board **remember to switch the microphone power supply on**. It is also **very important** to remember to type in the correct microphone sensitivity in the microphone Dialog Box, this is crucial for setting the correct measurement level. We have already dealt with level before, however here, things are more dangerous. Supposing the amplifier used has a gain of 30dB, a common value, leaving the CLIO output level at 0dB will cause the amplifier to deliver the equivalent of circa 40W/80ohm continuous. If the amplifier handles this power you will almost certainly burn your tweeter. If the amplifier is of lower power it is likely that it will saturate and burn your tweeter even faster! To avoid this embarrassing event, do as follow: enable CLIO input auto-range, open the Multi-Meter and select Pressure from the Parameter Drop Down. You will get the reading of your environmental noise. Fig.10.12 shows ours, we hope yours is lower!

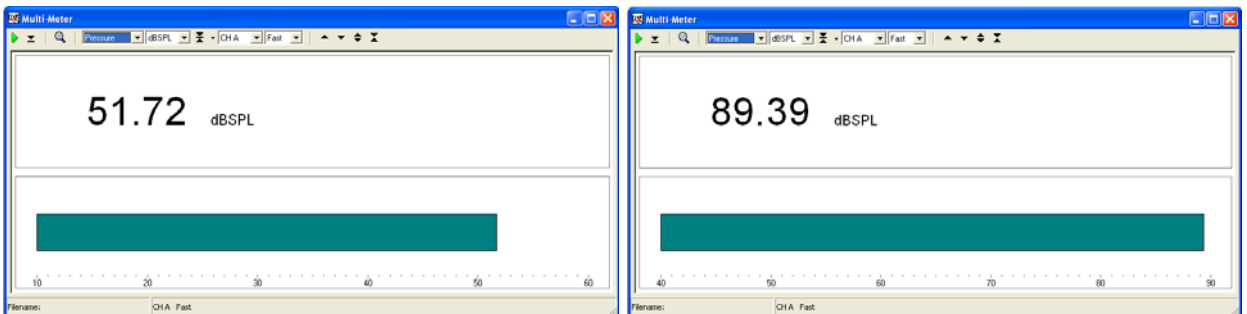


Figure 10.12 and 10.13

Now set CLIO output level to a very low value, -30 to -40dB and with the microphone positioned 70cm to 1m from the speaker start the MLS & LOG CHIRP signal. Increase the CLIO output level until you read 85 to 90 dB SPL as in Fig.10.13. Now go back to the MLS & LOG CHIRP Menu, select dB SPL as the Y scale unit and finally click on Go. The

speaker we are testing is a glorious Rogers LS3/5A, year 1978. Fig.10.14 shows our result.

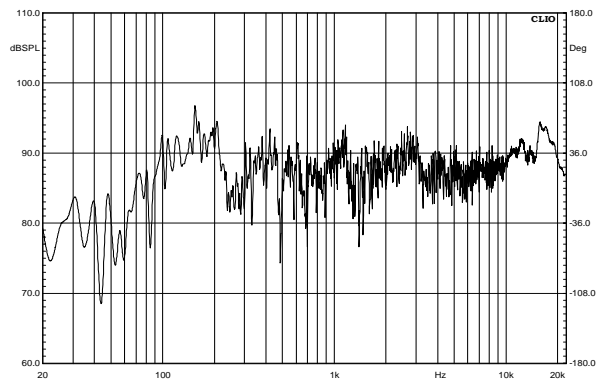


Figure 10.14

What you see is the speaker plus the room where we took our measurement, which is far from being anechoic. It is time to inspect the time domain. Clicking on the Time Domain button we get Fig.10.15 and, Fig.10.16, once we zoomed to the first 11ms and expanded the y scale.

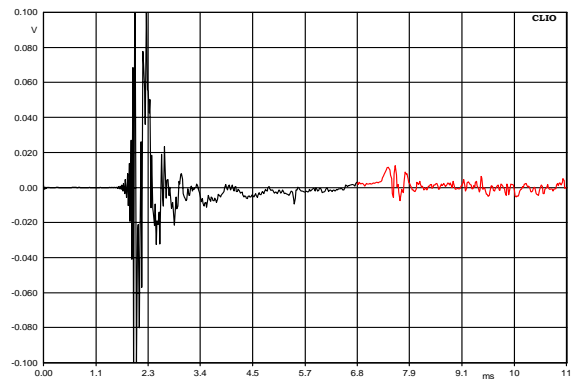
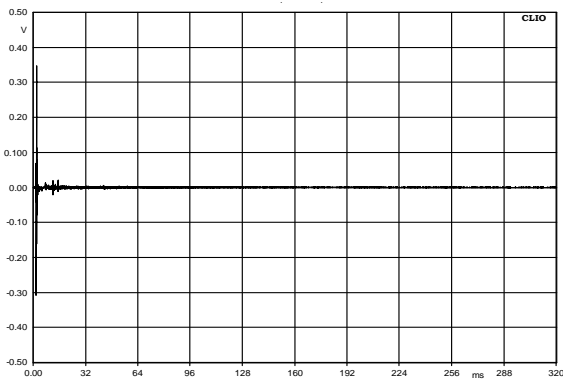


Figure 10.15 and 10.16

We also did another very important thing. At 7.3ms the first reflection due to the floor can be seen, just as expected from Fig.10.11. We set the marker at 6.8ms, which is just before the first reflection, and set the Stop Window there (see Chapter 8.5). By doing this CLIO will set all values of the impulse response received after 6.8ms to 0 before FFT is executed. In this way we simulate a reflection free environment. Clicking on the Frequency Domain Button we obtain Fig.10.17.

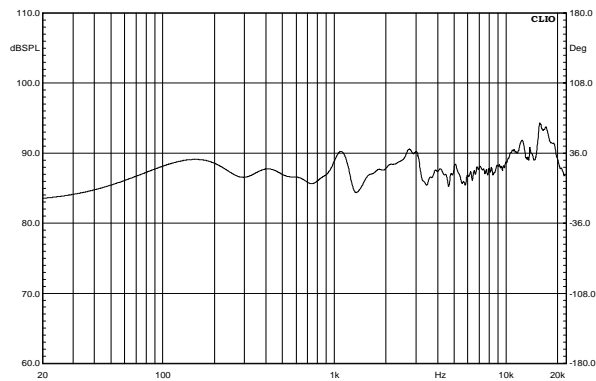


Figure 10.17

Now things look much better and this is almost the anechoic response of the speaker. However nothing comes for free. The low frequency part of the response seems quite optimistic for such a little speaker. The price we paid in setting the impulse tail to 0 is that we lost information on the lower part of the spectrum. The transition frequency between meaningful and meaningless data is calculated as 1 divided by the selected impulse length. In our case we selected a 6.8ms long impulse. $1/0.0068=147\text{Hz}$ right? Wrong. We have to remember the first 2 ms of the impulse, which is the time the sound takes to reach the microphone and hence does not carry any information. We could have selected the impulse as in Fig.10.18 without affecting the frequency response at all however phase response would have been greatly affected.

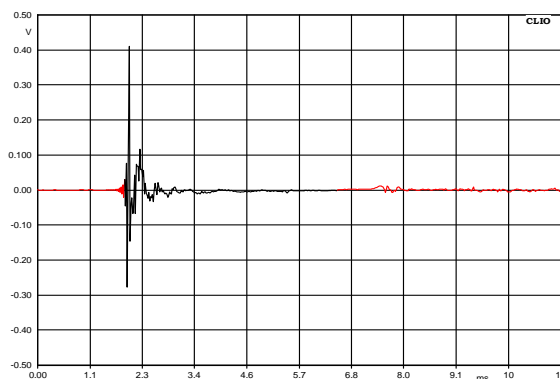


Figure 10.18

The right calculation is $1/(0.0068-0.002)=208.33\text{Hz}$. In our room the smallest dimension is floor to ceiling. This is indeed the most frequent case. This dimension is however 4m. The best location for the speaker would have been at 2m both from the floor and the ceiling. The second consideration is microphone distance. The further away it is, the more you have to subtract from the impulse length due to sound travel time to the microphone. In practice we do not encourage distance below 70cm for complete speaker measurement and you should increase to 1m for bigger ones. However single driver measurement can take advantage from a reduced distance.

10.4.4 PHASE & GROUP DELAY

We used the term "Frequency Response" to refer to graphs of Fig.10.5 and Fig.10.8. Frequency is in the x-axis in both figures. The units that respond to frequency, y-axis, are Volt and Ohm, respectively. Both of them are complex quantities (have real and imaginary parts) and their **magnitude** is shown. Doing this we obtained a very useful piece of information but we lost the original data (infinite numbers of different real and imaginary part can lead to the same magnitude). How this information loss will affect your results depends on what you are going to do with these graphs, or, better still, what the original question you were trying to answer was. Referring to Fig.10.5. A reasonable question could have been: how much does "A" filter attenuate a signal at 100Hz in respect to 1kHz? You go through the graph with the marker and answer 19.3dB. If you have the IEC 651 norm you can go to the "A" filter specs and you will find this attenuation should be 19.1dB +/- 0.5dB for type 0 devices. End of your job. Let's now pose another question referring to Fig.10.8: by how much would a 10kHz tone would be attenuated if we wire a 10 ohm resistor in series with that woofer? We are simply not able to give the correct answer. We need another piece of information, which is **PHASE**. Fig. 10.19 is the same measure of Fig. 10.8 with phase curve overlaid. To obtain it we just stored the magnitude curve and clicked on the phase button.

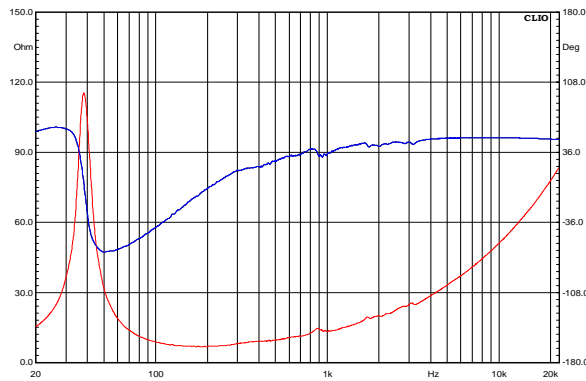


Figure 10.19

The same principal applies to acoustic devices. Fig.10.20 shows the magnitude response of a woofer and tweeter in a box without a cross-over network.

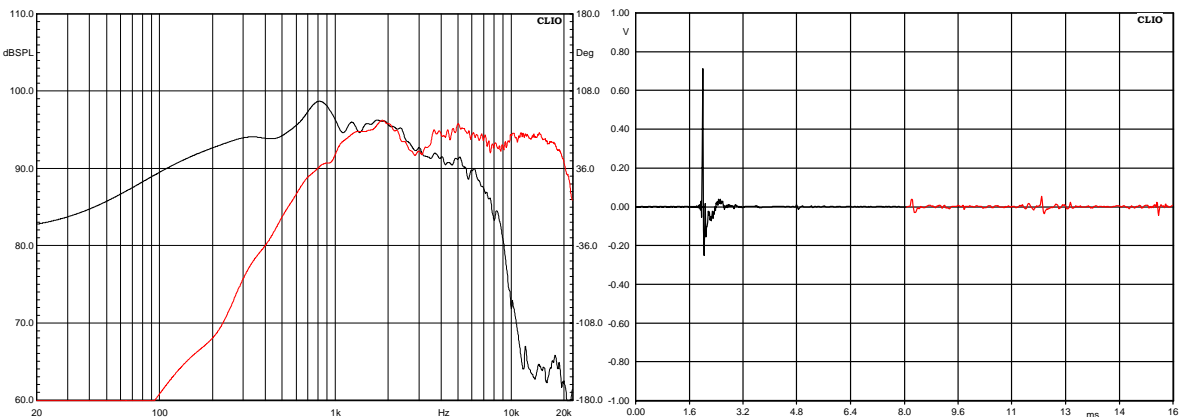


Figure 10.20 and 10.21

The two measurements were taken from the same microphone position. If we were to we ask ourselves which is the summed output we could not answer from the magnitude data alone. Unfortunately acoustic phase is not so easy to handle as electric phase. We are going to base our example on the tweeter, whose impulse response and window settings are in Fig.10.21. The procedure for the woofer would be exactly the same.

We will take this opportunity to introduce the use of the Wrapped Phase Button. Figures 10.22 and 10.23 shows the tweeter phase curve, unwrapped and wrapped.

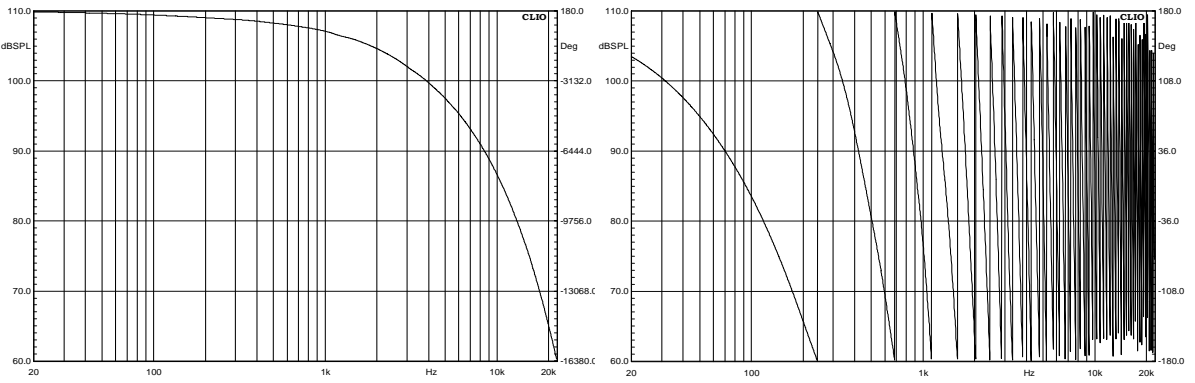


Figure 10.22 and 10.23

The reader may wonder if these figures are correct at all and if they have the same usefulness, at least visually. Well, the curves are absolutely correct; their visual usefulness is zero for the wrapped curve and low for the unwrapped. Difficulties in getting simple visual information from these curves arise because they are the sum of two effects. The first one is the devices own phase response. The second is the time of sound flight. The latter does affect the curves much more than the first one, completely burying it. The good news is that it is often possible to separate these two effects. However, the bad news is that this is not an easy task. Trying to explain it, without going into heavy mathematics is very difficult. The bibliography in this user manual should be considered as an integral part of it here. Within CLIO the time of flight can be removed in several different ways, with different degrees of accuracy. The most accurate is also the most complicated and is how we are going to proceed. Fig. 10.24 introduces us to **Minimum Phase**, which is the heart of the whole procedure.

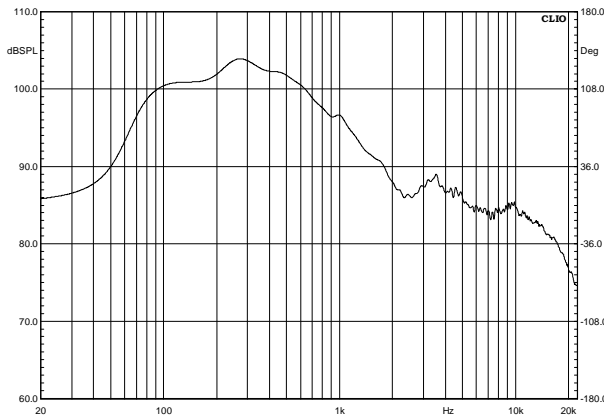
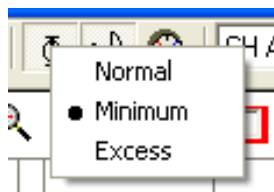


Figure 10.24

We obtained it by selecting minimum phase in the MLS phase Drop Down Menu (right click on the phase speed button).



Certain well-behaved systems are defined as Minimum Phase. In these, the phase response can be obtained from the magnitude response by calculation. Another kind of phase (we promise it is the last one), is **Excess Phase**. This is the algebraic difference

between true phase, as in Fig.10.22, and minimum phase. It is exactly what we need to separate the time of flight from the device's own phase response. We won't use excess phase directly here but a post process of it, **Excess Group Delay**. Fig.10.25 is the excess group delay of our tweeter vs. frequency.

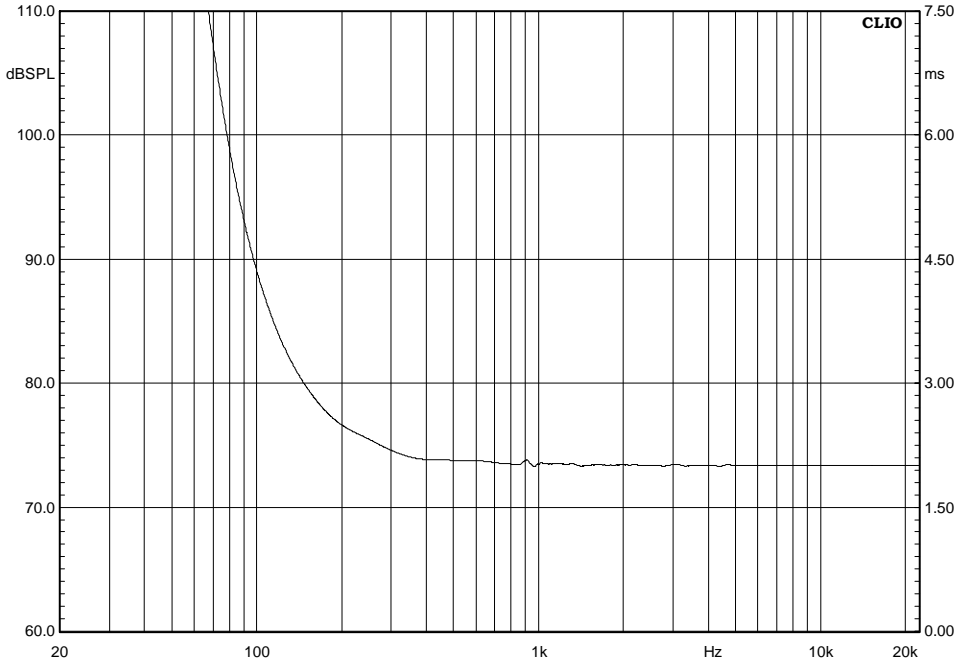


Figure 10.25

It was obtained by selecting Excess in Drop Down Menu. This graph represents the distance of the sound source from the microphone vs. frequency. As long as the distance is constant the system is minimum phase and we are in the position of a well defined acoustic centre. If you recall from previous paragraphs we have reliable data down to 200Hz because of the time windows. As we deal with a tweeter we will consider the 2k-20k frequency range where the marker reads a constant 2.01ms. We will use this value to operate a time shift that removes the sound flight time. This is accomplished from the Processing Tools Dialog, selecting Time shift and typing the value we found as in Fig.10.26.

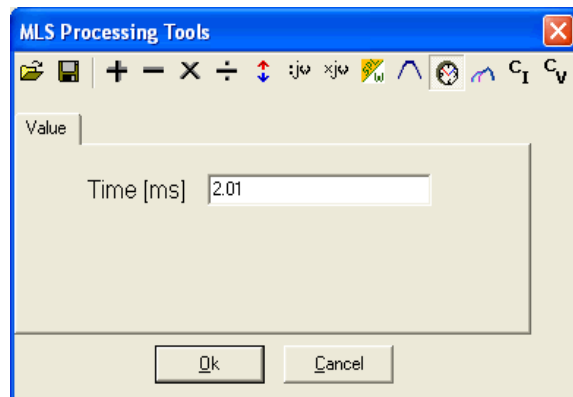


Figure 10.26

Clicking OK we can finally display the processed phase, minimum phase and magnitude response of our device in Fig. 10.27. We used the term "processed phase" here and this is not casual.

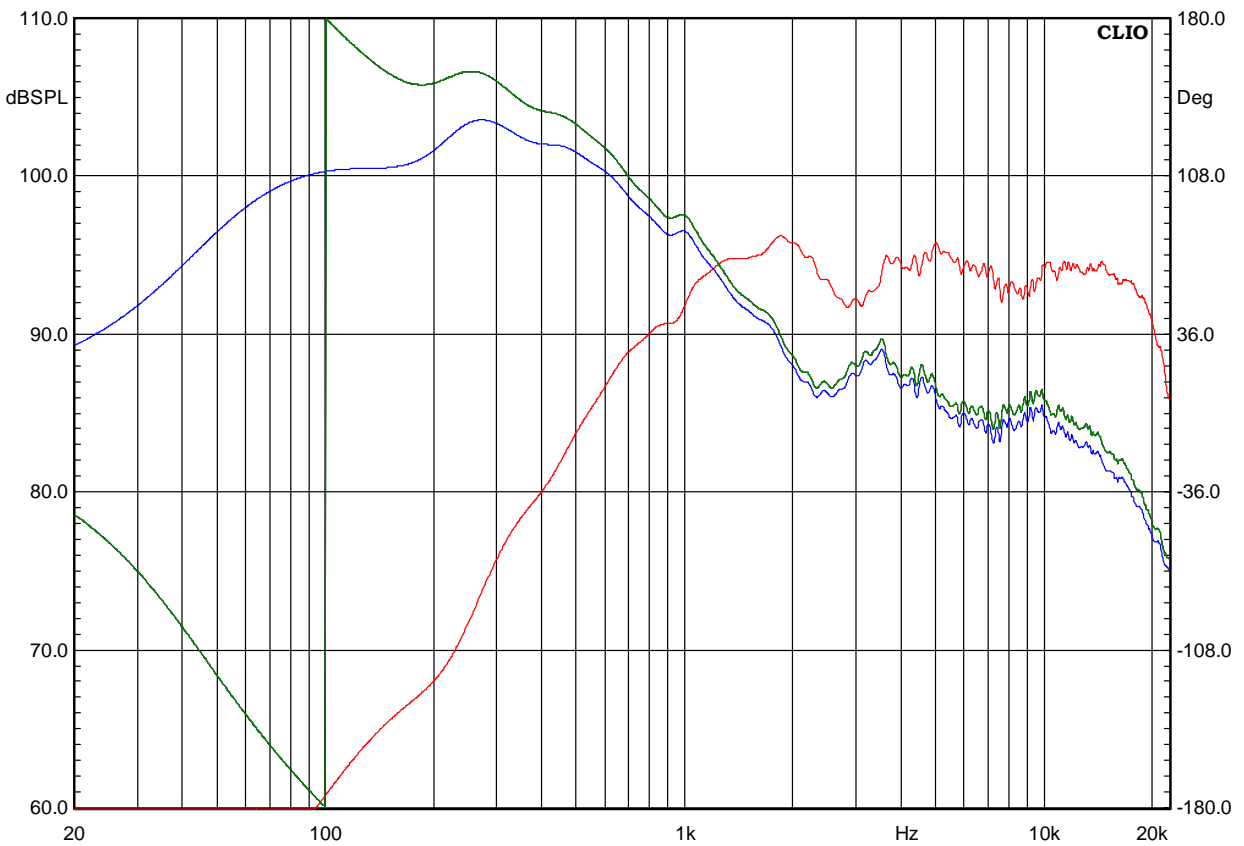


Figure 10.27

To finish this difficult paragraph we will summarize what we did with some comments. Measuring acoustic phase response is often far from a "press a button and get it" procedure. We went through several phase plots, all looking different but, this is an important point, all correct. It is common to identify the processed phase as the true one only because it looks better. It is important to stress that the true phase is that of Figures 10.18 and 10.19. CLIO, which is intended as a computer based instrument, can, as we will see later, easily calculate the summed response of woofer and tweeter after they are taken separately but with the same microphone position. What we did with our complicated procedure was to obtain a response as if the microphone would have been exactly in the acoustic centre of the driver. The most obvious application is to furnish data to cross-over CAD programs.

10.5 OTHER TIME DOMAIN INFORMATION

Besides the impulse response we already dealt with, CLIO gives three more time related post processing, which are ETC, Step Response and Schroeder Plots. The last is room acoustic oriented and we will handle it later with a T60 calculation example. ETC and Step Response are shown here, Fig.10.28 and 10.29; they are relative to the system of Fig.10.15.

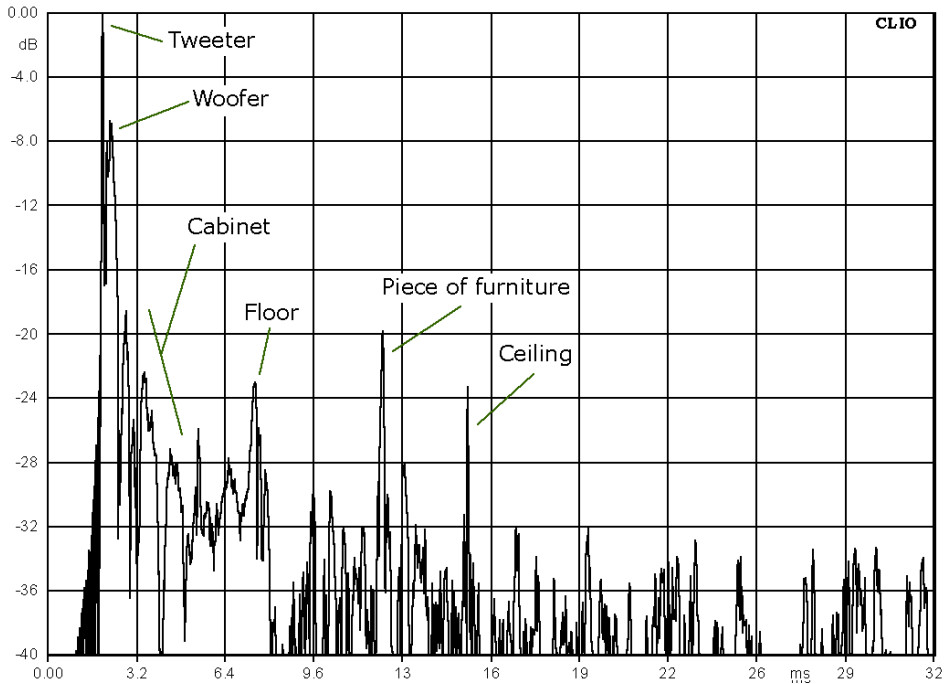


Figure 10.28

Interpretation of ETC, besides the most obvious things which are labeled inside the figure, requires some theoretic digressions beyond the scope of this user manual as the topic is still debated.

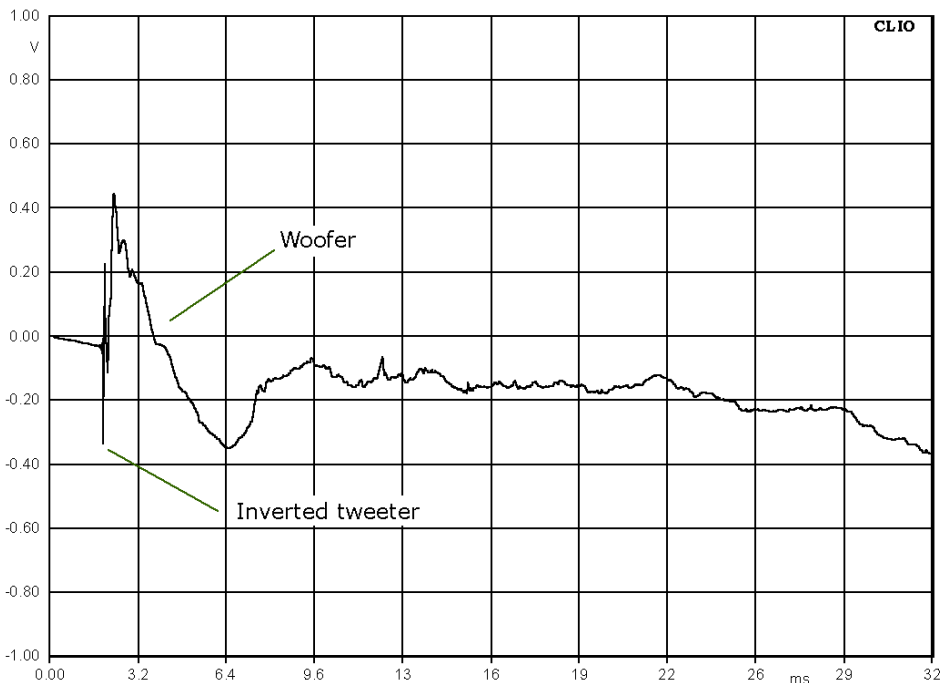


Figure 10.29

Step response is very useful to identify differences in arrival time between drivers as well as their polarity.

10.6 PROCESSING TOOLS BY EXAMPLE

CLIO has powerful processing tools that can be helpful in several circumstances. We saw the basics at the beginning of this chapter. It was just a brief description of the kind "press this to do that". Here we are going to use some of them in practice. Some general rules apply to a group of them for four basic operations. You can add, subtract, multiply and divide the data in memory either with a single complex value or with a **compatible file**. Compatible means that it must be a file with the same basic settings as the one in memory. Y-scale must also be the same that is you cannot add dBV with Ohm. The use of Load Process and Save Process, will become clearer as we review the examples. The Add and Sub functions are used mostly among files. We will use them to obtain the sum and difference of the woofer and tweeter of Fig. 10.20. Results are in Fig. 10.30 where the sum is in red and the difference in blue. These are useful plots to start with during a cross-over design. For example it is interesting to consider the big notch in the sum curve, something not easy to imagine from the magnitude response.

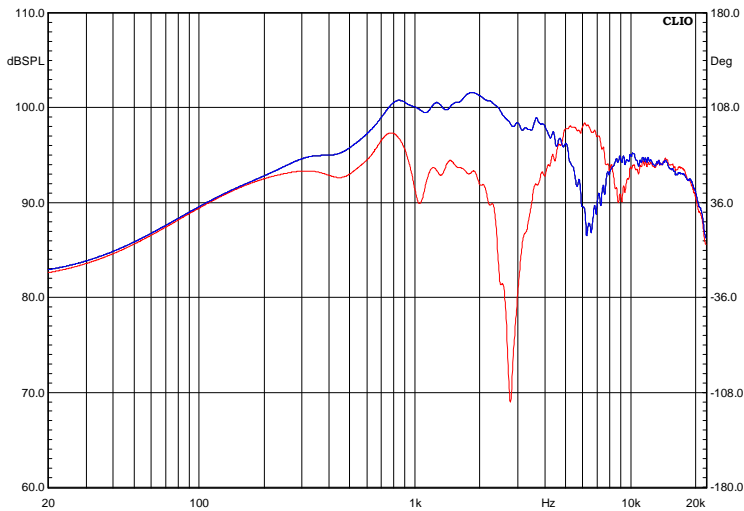


Figure 10.30

The divide function, in its most classical use, allows the user to show a magnitude response as a transfer function with another measurement. Suppose you want to evaluate how the grid affects the frequency response. We will use the response of Fig. 10.17 as a reference, which has been taken with the grid in place. We remove it, take another measurement, and perform a division by file with the grid in place. We remove it, take another measurement, and perform a division by file with the data of the reference. Result is in Fig. 10.31.

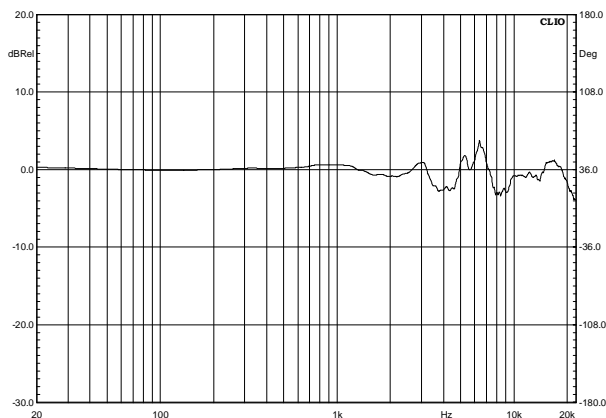


Figure 10.31

Note that the y-scale has been automatically changed to dBRel. This is a good point to introduce the use of Load and Save process together with the Automatic Processing

button. Any process you execute can be saved to disk and will have "mpro" extension. This allows you to recall any value or file path later on by loading this file again. Suppose you have a small production of ten speakers that you want to test against a previous produced reference which you know is fine. You just have to define and save a process that divides the current data with the reference. Testing a device against itself should produce a flat line, within the frequency range of the device, and this should be checked before saving the process. When you need to check your batch you just recall your process. This will activate the Automatic Process button. When this button is activated any subsequent measurement is processed before it is displayed. The next process we will consider is the **dB SPL/Watt**. It requires a file and an impedance value and allows us to obtain a frequency response plot referred to 1W at the speaker terminal whatever the real measurement level is. To make this possible an electrical measurement at the speaker terminal (power amplifier output) must be taken, with dBV as y-scale, and used as a reference file. A value of impedance is also necessary that allows CLIO to convert voltage to power. We will go through the entire procedure using the tweeter of the previous examples. Since what we are looking for is the response in a 1W-1m condition we have to move the microphone to a distance of 1m from the tweeter (it was at 69.14cm). The 1m condition can be set directly with a meter. Fig.10.32 shows the 1m measurement in black and the previous one in red. Signal level at speaker terminal is unchanged. The average difference being 3.3dB.

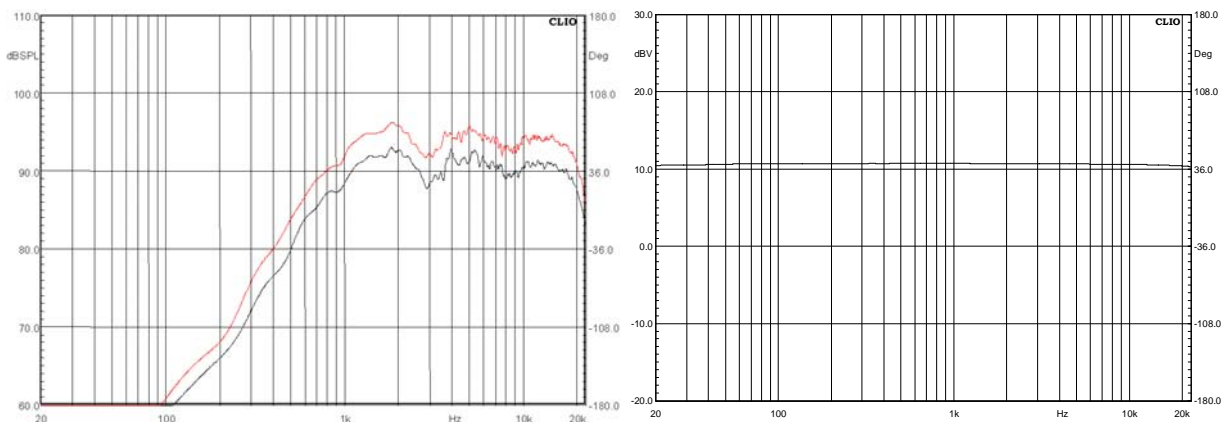


Figure 10.32 and 10.33

We now connect CLIO's input to the speaker terminals and change the y-scale to dBV, **do not change** CLIO's output level, we then obtain Fig.10.33. This is a nearly flat line that indicates the voltage delivered to the speaker. Remember to save the measurement to disk. It is worth pointing out that deviation from linearity in this curve due to the power amp or cable would be compensated for by this procedure. Now we reload the response at 1m, go to the Process Dialog that will appear as in Fig.10.34.

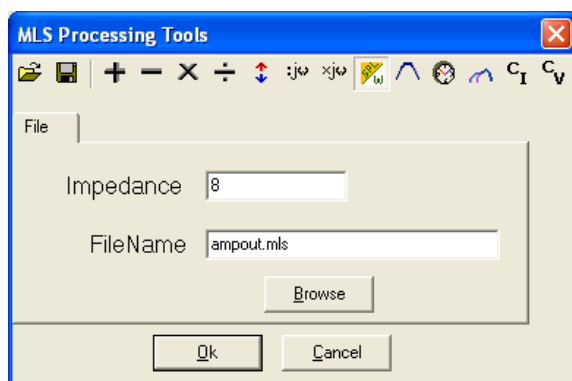


Figure 10.34

We set the impedance to 8 ohm as this is the nominal impedance of the tweeter. Clicking OK we obtain Fig.10.35, which is the final result.

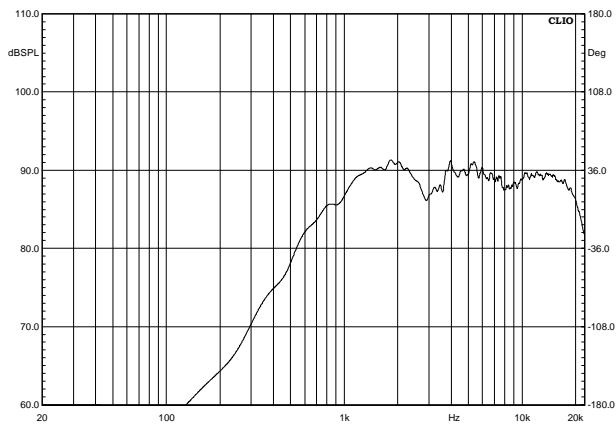


Figure 10.35

Our last example will cover the **merge function**. When we measured the system of Fig.10.17 we stated that the lower frequency limit that had to be considered reliable was 208Hz. We can easily overcome this limit taking another measurement with the near-field technique and merge the result with the data of Fig.10.17. Doing near-field measurement you should readjust the output level so that the maximum sound pressure does not exceed 110dB SPL as this will prevent Microphone overload problems. Fig.10.36 shows both the near-field and far-field response. Notice the big level difference. To merge them it is the far-field measurement which should be the one in memory. Fig.10.37 shows the Merge Dialog with a transition frequency set to 350Hz.

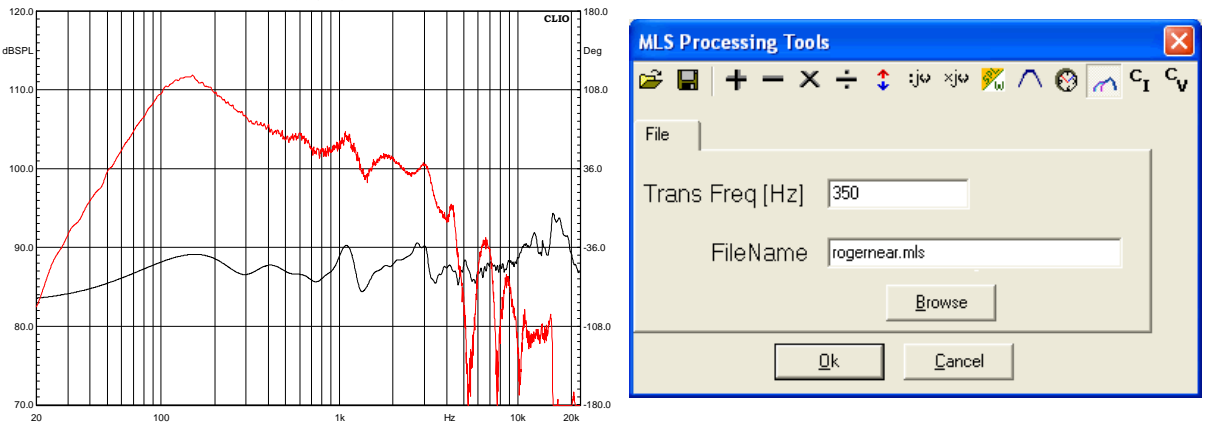


Figure 10.36 and 10.37

Fig.10.38 shows the merged response. Notice that the near-field measurement level has been scaled to the far-field one. Two very important functions, **CV function** and **CI function**, are explained in Chapter 13 as they are impedance tools.

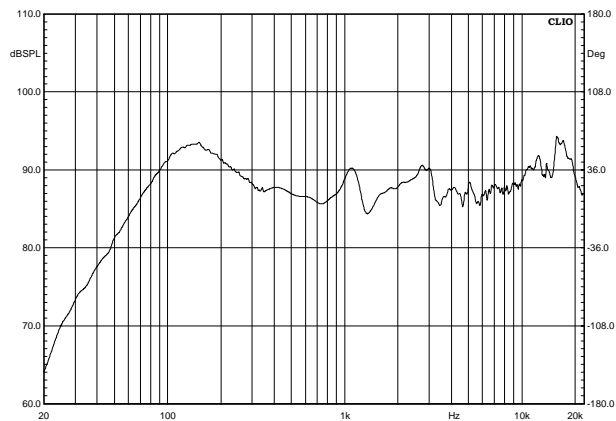


Figure 10.38

10.7 MLS Vs. LOG CHIRP

As anticipated in the introduction, some advice are given to help choosing between MLS and LOG CHIRP stimuli. Both approach are valid and bring to equivalent results. In both cases the device we want to measure is assumed to be Linear and time Invariant. This assumption while reasonably true in general cases in never met in absolute terms. There is always a certain degree of non linearity and, in less degree, a time variance. The two approach shows different sensitivity to these facts. Advantage of MLS are that is that much less computing requiring, historically much more widespread and known and has a flat frequency energy distribution. The latter feature can be an advantage or not depending on situation/DUT.

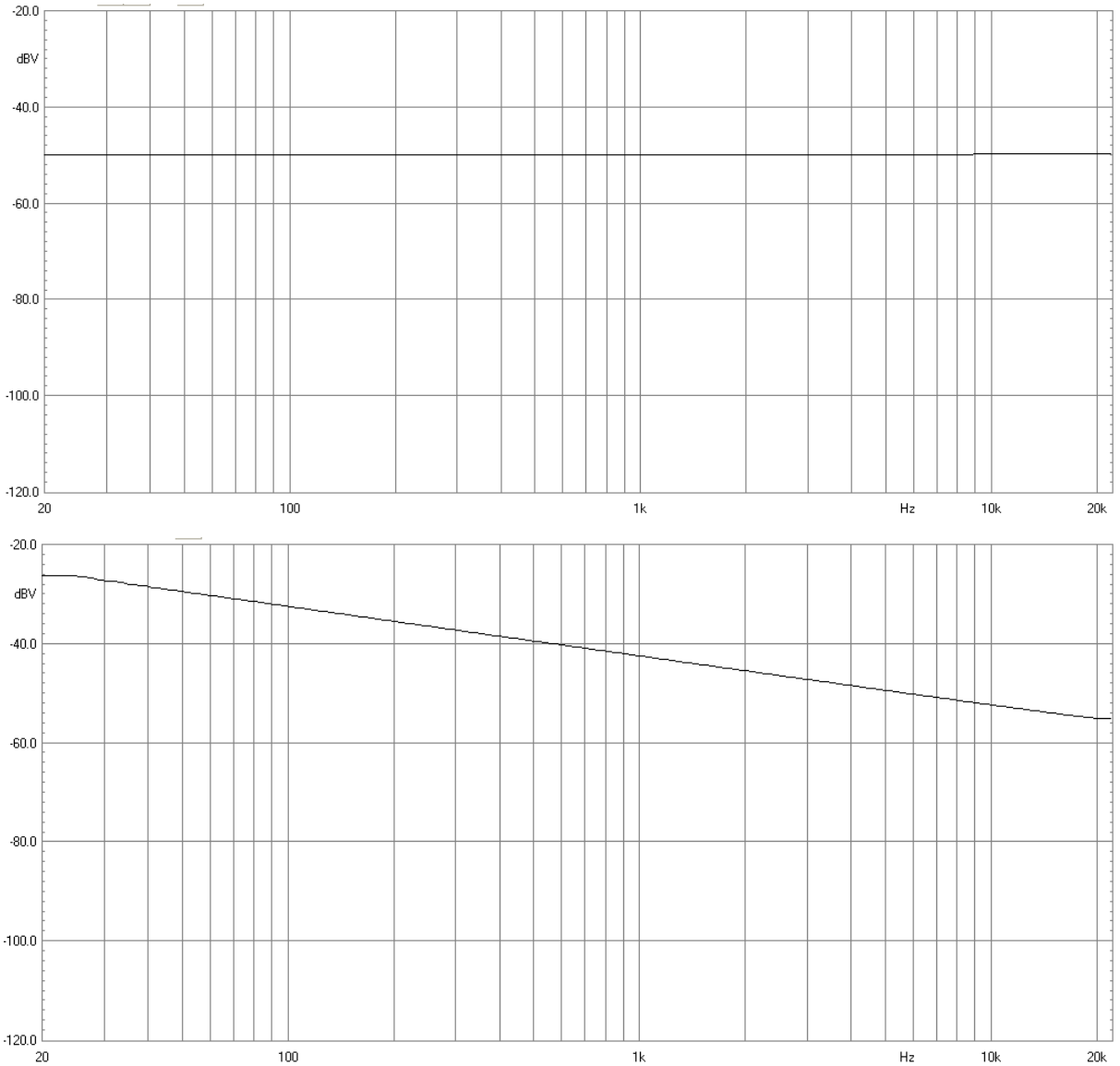


Figure 10.39

In the above figures the spectrum of both signals is showed. As usually signal to noise ratio get worse at lower frequency, the higher signal energy that LOG CHIRP has here is an advantage for S/N ratio. If the DUT does not appreciate low frequency high energy content, i.e. a tweeter, the advantage become a disadvantage.

Also, there is an important difference on how non linearity affects the two procedure. In MLS distortion transforms itself in noise spread over the whole impulse response while with LOG CHIRP concentrate itself in single impulses (one for each harmonic) in the tail of the impulse and can easily be manually removed.

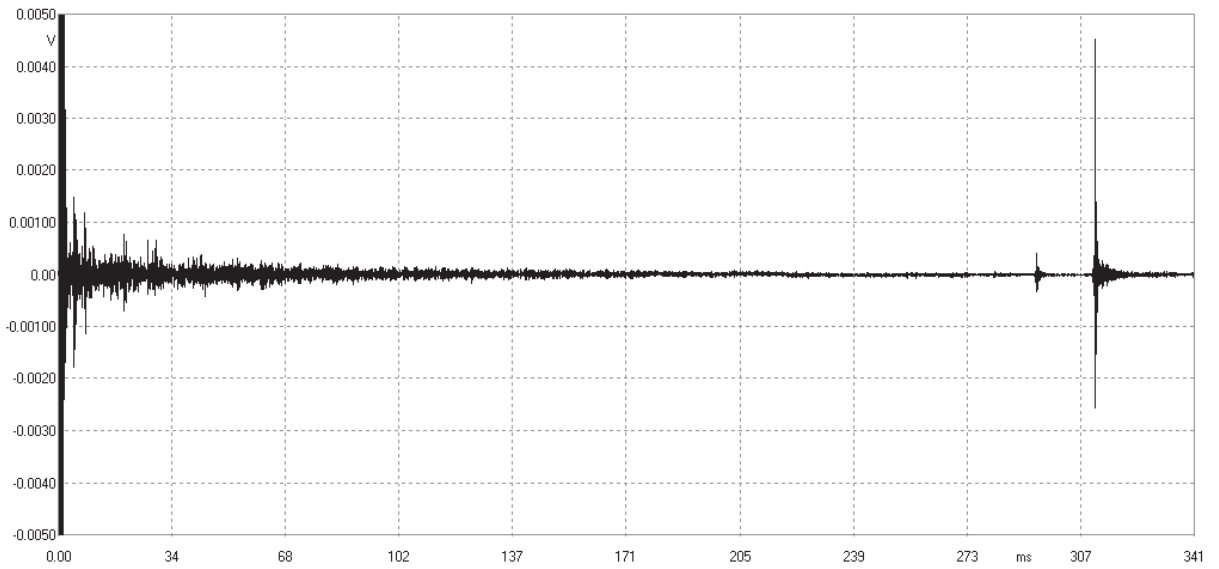
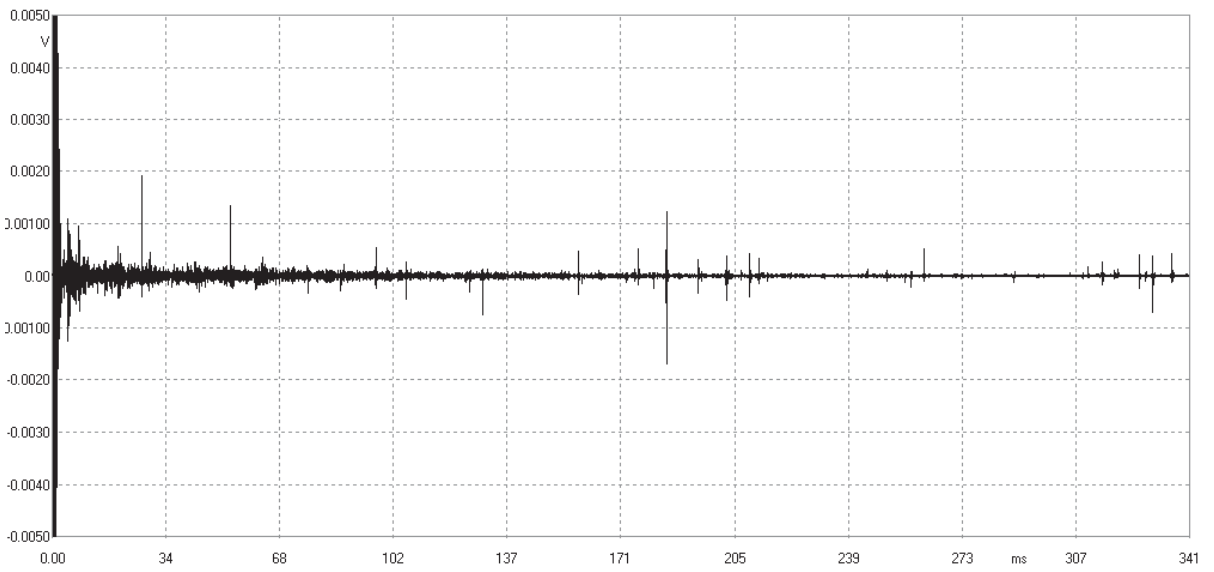


Figure 10.40

Finally a brief note on level. Setting the CLIO's output level to 0dB you'll have -5.2dBV with MLS and -2.2dBV with the LOG CHIRP, exactly the same level that you'd have within the Sinusoidal menu. While this is our choice, it is a by-product of the fact that MLS, in real life, has a higher crest factor than a sinusoidal signal.

10.8 RELATED MENUS

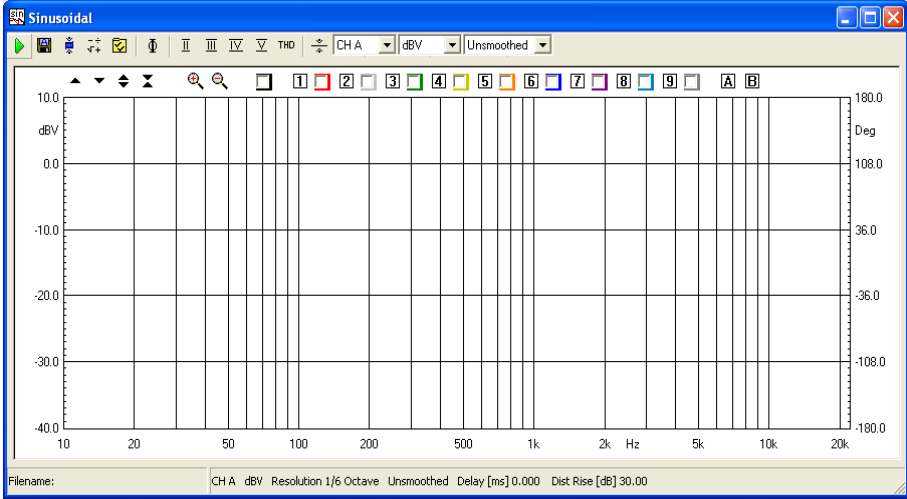
The dual domain data, Frequency and Time, obtainable within this menu, are the starting point for many kind of post processing. While some can be done within MLS & LOGCHIRP, using the **Processing Tools**, the Time Domain features (ETC, Schroeder Decay, Step response, window selection, transform start and end points) both complexity and results presentation flexibility suggested to implement two very important post processing in separate menus. These are **Waterfall & Directivity** and **Acoustical Parameters**. Each has its own dedicated chapter explaining how to use this powerful Post Processing features. However they completely rely on measurement you have done here. The ill-famed saying "rubbish in rubbish out" apply. Before dealing with post processing, be sure to have reliable measurements, with good S/N ratio, optimum size and Sampling Frequency, as pointed out during this chapter.

11 SINUSOIDAL










11.1 INTRODUCTION

Within Sinusoidal, it is possible to carry out Frequency Response Analysis, Impedance Analysis and Distortion Analysis. As should be obvious the stimuli used is a Sinusoidal signal, stepped or continuously swept within user defined Frequency limits. Although Sinusoidal steady state analysis is among the oldest and more traditional kind of measure, CLIO merges the reliability of this well known technique with the power of advanced DSP. The completely programmable Gating feature allows the user to add quasi-anechoic Frequency Response capability.

11.2 SINUSOIDAL CONTROL PANEL




11.2.1 TOOLBAR BUTTONS

-  Starts the sinusoidal measurement.
-  If pressed the measurements will be autosaved. The current autosave definitions apply; see 6.3.1 for details.
-  Automatically applies the defined post-process $\frac{-}{\sqrt{+}}$ after the measurement has been taken.
-  Enters the Sinusoidal Post-Process Dialog, described below.
-  Displays the phase response instead of modulus response.
-  Enters the Sinusoidal Setting Dialog, described in detail below. It is the heart of the whole menu and should be thoroughly understood before pressing Go.
-  Displays second harmonic distortion, risen the amount of dB defined in the Setting Dialog.
-  Display third harmonic distortion, risen the amount of dB defined in the Setting Dialog.
-  Display fourth harmonic distortion, risen the amount of dB defined in the Setting Dialog.

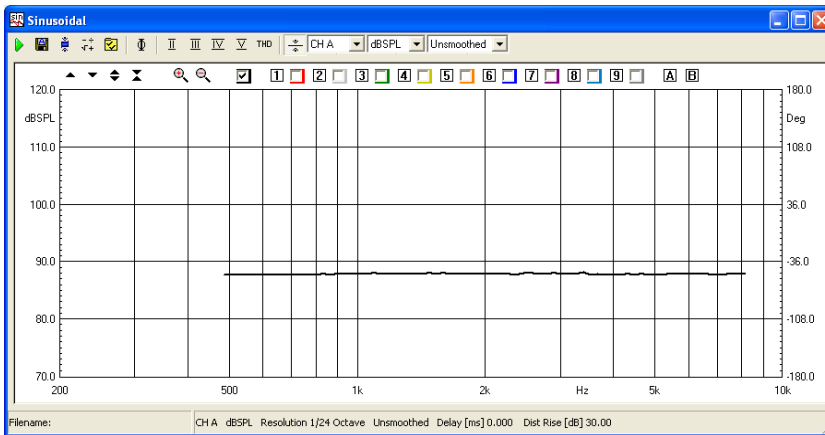
 Display fifth harmonic distortion, risen the amount of dB defined in the Setting Dialog.

THD Display total harmonic distortion, risen the amount of dB defined in the Setting Dialog.

 Set output level equalize mode; after a sinusoidal measurement has been taken it is possible to refer to the acquired frequency response in order to generate a colored output that flattens out the subsequent response. For example if the following pressure response has been measured



It is possible to obtain flat output from the same loudspeaker simply pressing the equalize button




11.2.2 TOOLBAR DROP DOWNS

input channel

Selects the input channel configuration. See 5.6 for details.

Y Scale units

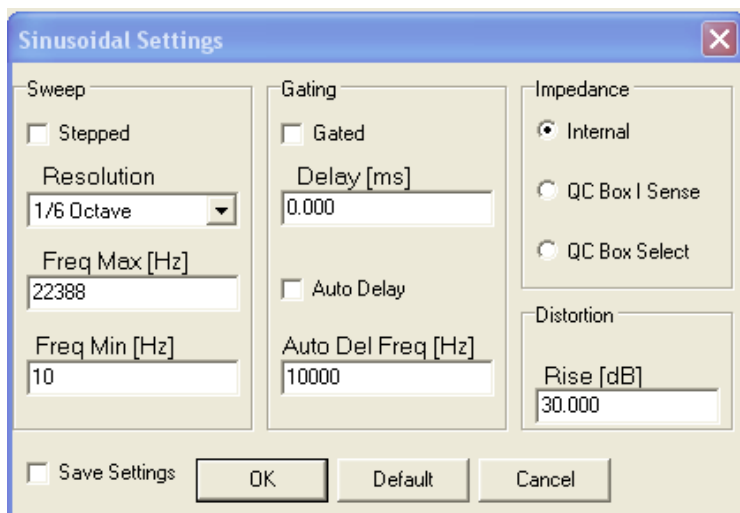
Selects the measurement Y scale unit. Possible choices are dBV, dBu, dBRel as Voltage units, dB SPL as pressure unit, Ohm as impedance unit. dBV and dBu refer the 0 dB on the scale to 1 V and 0.775 V, respectively. dBRel refers to the 0 dB on the scale to the value set within the MULTI-METER. dB SPL switches the system to work in pressure mode. A conversion from Volts to Pressure is accomplished, based on the Microphone sensitivity set in the dedicated Dialog . Once the measurement is taken the conversion is done and all the internal data is stored in Pressure. This means that further changes to Microphone sensitivity does not affect any data in

memory or saved measurements. Ohm switches the system to convert the measurements in Ohm basing the conversion on the Impedance Mode Settings available in the Settings Dialog. Again, once the measurements have been taken the data is immediately converted.

Smoothing

Allows the user to select a Frequency smoothing of the active curve. The smoothing algorithm averages all the value within the selected fraction of octave band, surrounding each analysis Frequency. It is a non destructive post process that can be applied or removed at any moment after the measurement has been taken.

11.2.3 SINUSOIDAL SETTINGS DIALOG



This is undoubtedly the most important User Interface of the entire Menu. Here the single action of every control is considered. Theoretical and practical effects on the subsequent measurement are considered later.

Sweep Settings

Stepped Check Box

Allows the user to choose between continuous or stepped Logarithmic Sweep. Continuous sweep is faster but, therefore, should only be used if it's clear to the user how this affects the measurements.

Resolution Drop Down

Lets the user choose between five different Frequency resolutions. It affects the measurement execution time, whatever the other settings are.

Freq Max Edit Box

Lets the user define the highest Frequency of the Sweep. This is also the starting measurement Frequency. The highest value accepted is 22388 Hz. The value should also be one octave higher than the Minimum Frequency.

Freq Min Edit Box

Lets the user define the lowest Frequency of the Sweep. This is also the end measurement Frequency. The lowest value accepted is 10 Hz. The value should also be one octave lower than the Maximum Frequency.

Gating (Acquisition) Settings

Gated Check Box

Lets the user enable the gating acquisition mode. Checking it will automatically check Stepped Check Box. That is, Gated Measurements are always carried out in Stepped Mode.

Delay Edit Box

Lets the user define the delay, in ms, applied between the signal generation and its acquisition. When different than 0, gating is active, even when gating or Stepped check boxes (but not both) are not checked. Typical gated use is quasi anechoic Frequency Response Analysis where it removes the time delay of the sound leaving the Speaker and reaching the Microphone. Alternative use, with gated not checked, might be removing the delay between the play and recording head in a three heads tape recorder as well as any digital processor that introduces delay in the signal path. When the settings are Not Stepped and Not Gated the delay value is reset automatically to 0; CLIO introduces a large delay anyway between start of generation and acquisition. The highest Delay value accepted is 320ms.

Auto Delay Check Box & Auto Delay Frequency Edit Box

If Auto delay is checked, when delay is used (see above) CLIO tries, using the Frequency entered in the Edit Box, to determine the delay automatically. The value found is displayed in the Delay Edit Box; reopening the Settings Dialog after the measurements has been taken allows to you to view the automatically chosen delay time.

Impedance Settings

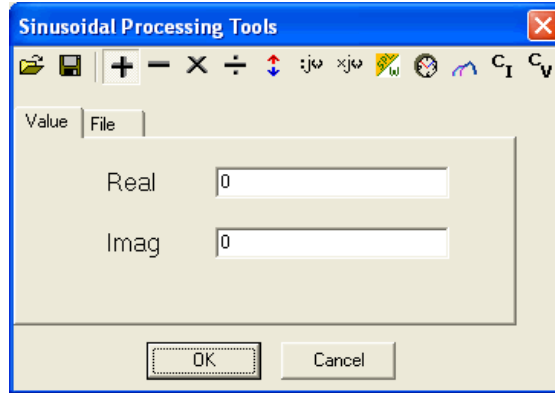
Set how Impedance is calculated. When taking impedance measurements refer either to the **internal** impedance mode or to the **ISense** feature of the CLIOQC Amplifier & SwitchBox Model 2,3 and 4. If **QC Box Select** is selected the hardware setting of the QC Box determines directly the Impedance Mode (please refer to chap. 5.5.1)


Distortion Settings


An Edit Box allows you to type in the value, in dB, used by the graphical routines to raise the display of the distortion curves. Only the display of the curve is affected. The marker readings continue to display the real value which, if the rise value is different than 0, differs from the curve position.

11.2.4 SINUSOIDAL POST PROCESSING TOOLS

The POST PROCESSING Dialog gives access to very powerful tools that, once defined, can be saved, reloaded and automatically be applied to every executed measurement.





 Loads a Sinusoidal process.

 Saves a Sinusoidal process.

 Adds a data value or compatible file to the current measurement.

 Subtracts a data value or compatible file to the current measurement.


 Multiplies the current measurement by a data value or compatible file.

 Divides the current measurement by a data value or compatible file.


 Shifts the current measurement by a dB value.


 Multiplies the current measurement by complex frequency.


 Divides the current measurement by complex frequency.

 Uses a reference measurement file taken at speaker terminals to calculate 1m sensitivity in dB SPL/W. The reference file should have dBV units while the one in memory should be in dB SPL.

 Temporally shifts the current measurement by a ms value. Affects phase response.

 Merges the current measurement with the part below the selected transition frequency of a selected compatible file.

 Combines the current measurement and the selected file to obtain a constant current impedance measurement. Both files should be in dBV.

 Combines the current measurement and the selected file to obtain a constant voltage impedance measurement. Both files should be in dBV.

11.3 A BRIEF DESCRIPTION ON SETTINGS EFFECTS

11.3.1 STEPPED VS. NOT STEPPED

Although measuring speed increases, use of a “not stepped” sweep can adversely affect measuring results in several circumstances. As an example that should make this clear, let’s see what happens while measuring the impedance of a woofer in Internal or Constant Current Mode. Please refer to Measuring Impedance for more information on this topic. In both conditions the loudspeaker is driven from a high impedance source and its damping is only mechanical. Fig.11.1 shows a 6" woofer, driven by a 100Ohm output impedance generator delivering a sinusoidal burst 200ms long, at its resonance frequency. When the excitation stops, the device continues to move, and therefore produce back electromotive force (EMF) voltage for more than 50 ms. Something very similar happens at start-up. In this situation, if CLIO is set in “not stepped” mode, it will acquire this EMF together with the actual results.

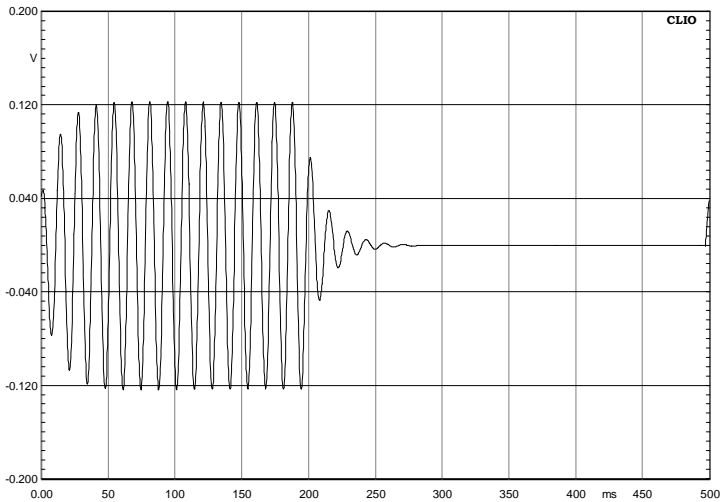


Figure 11.1

Fig.11.2 shows the same driver impedance taken both in stepped (black) and “not stepped” mode (red). The “not stepped” curve is simply wrong. Conclusion: use always stepped mode or the highest frequency resolution if the behavior of the device to be measured is unknown.

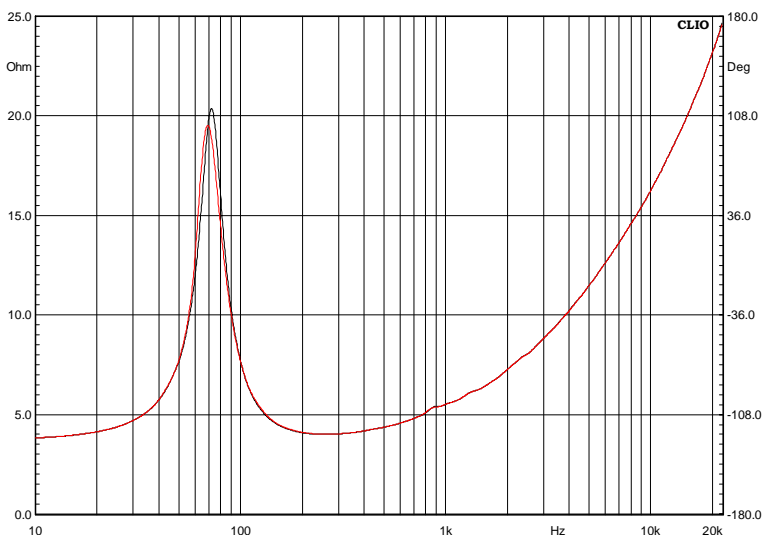


Figure 11.2

11.3.2 FREQUENCY RESOLUTION

Here the lower the resolution the faster the measuring time. Impedance measurements are again a powerful way to explore problems. Fig.11.3 shows two impedance measurements taken from the same 16" woofer with 1/24 octave resolution (red) and 1/6 octave resolution (black). Deriving T/S Parameters from the black curve would lead to serious errors. This is an extreme case, a huge woofer with high Qms. Different curve shapes can sometimes be accurately quantified even with 1/3 octave resolution.

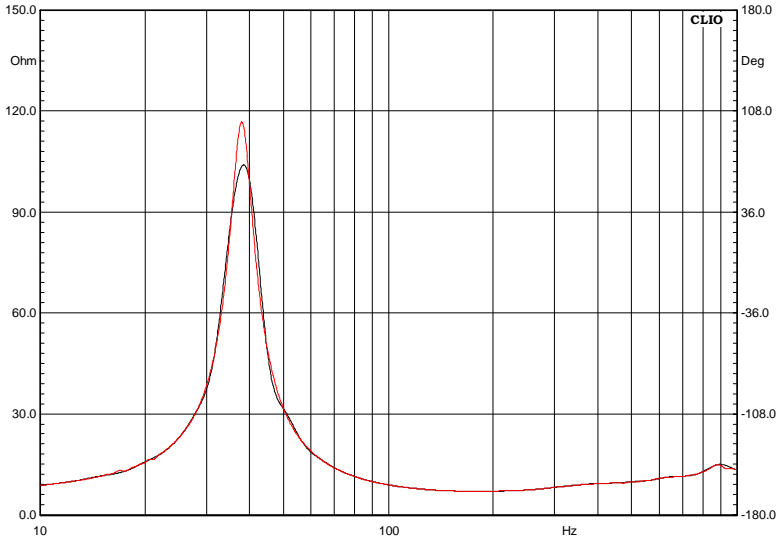


Figure 11.3

11.3.3 GATING

Enabling Gating allows quasi anechoic Frequency Response to be carried out in normal environments, with obvious and less obvious limitations. Regarding the geometrical environment required, Sinusoidal analysis does not differ from what has been said about MLS. Nevertheless the latter gives a much more intuitive approach. It is strongly suggested that you become very familiar with quasi anechoic measurements using MLS before dealing with Gating. What follows is a brief description of the parameters involved. We are going to use some figures to help our understanding. Fig.11.4, repeated from the MLS chapter, shows a typical setup, while Fig. 11.5 shows what really happens, using as stimuli a 20ms 1kHz Sinusoidal Burst.

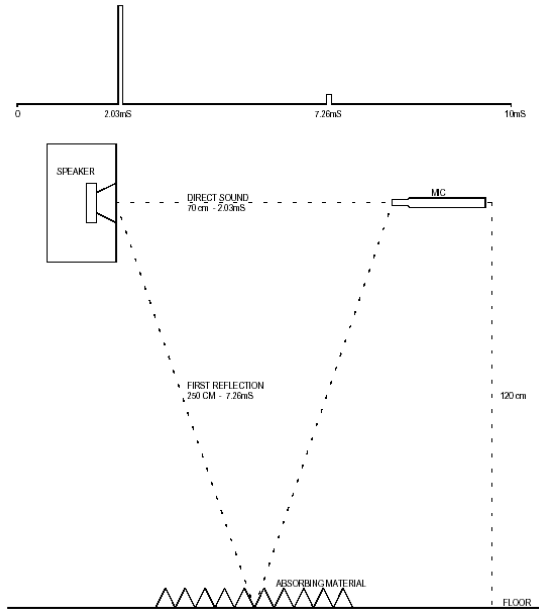


Figure 11.4

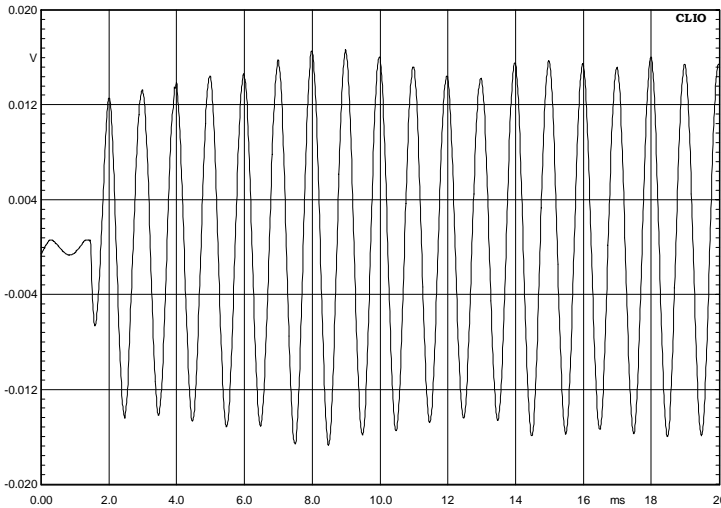


Figure 11.5

The time of the sound propagation delay is clearly visible at the beginning, roughly 1.3ms. This is the value users should input in the Delay Edit Box. Thereafter is the short time that the device takes to start. This is usually short enough to not affect amplitude evaluation but adversely affects distortion measurements. At 7 and 8 ms, where there are two consequent sinusoid positive peaks, an increase in level is clearly visible. This is the effect of the first reflection (floor); as it affects amplitude evaluation it should therefore have been stopped before it is processed. The time the system evaluates the signal is usually defined as Meter On time. This is automatically set by CLIO around the

value of 6 ms, as long as the Frequency involved is high enough to allow this. Fig.11.6 is a plot of the Meter On Time Vs Frequency CLIO uses.

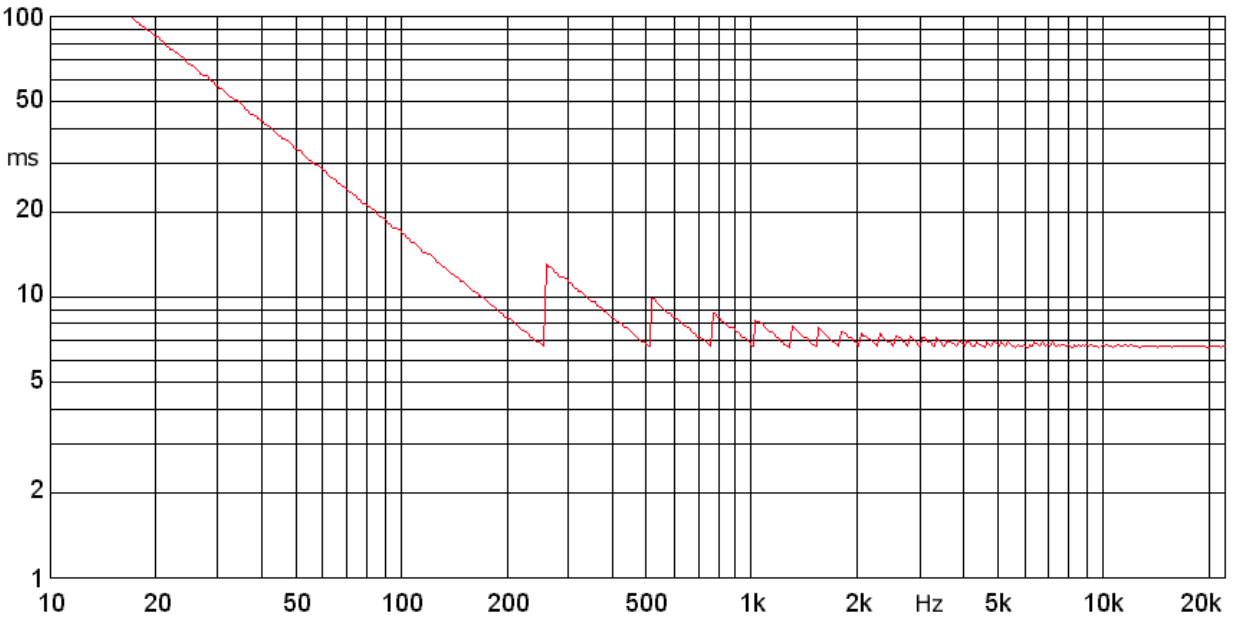


Figure 11.6

Users should use this graphic to determine the lowest Frequency that has been measured in anechoic state. Using a fixed predefined Microphone and Loudspeaker location makes all these parameters easier to define in routine measurement processes. But for new situations it's very advisable to run an MLS and have a look at the impulse response obtained. Fig.11.7 shows the labels of the corresponding data to be input as gating parameters.

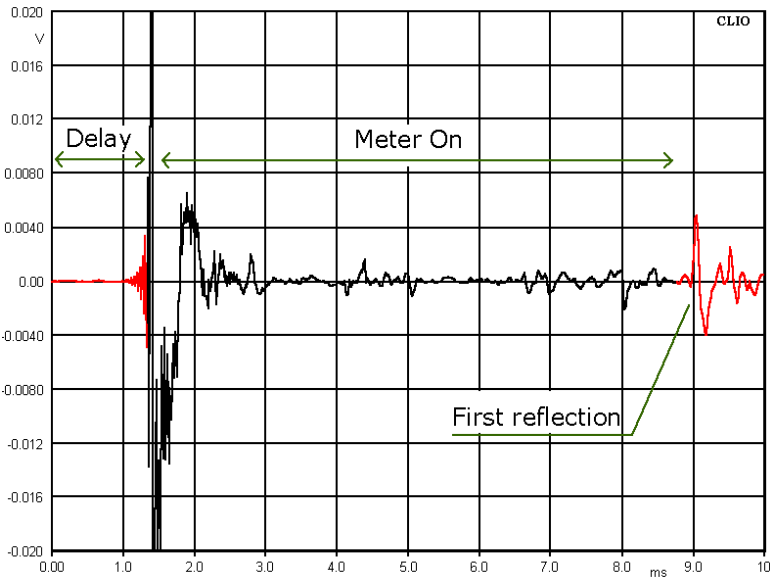


Figure 11.7

11.4 DISTORTION AND SETTINGS

Sinusoidal stimuli allow CLIO to evaluate distortion in its single harmonic form. If not Set in Impedance Mode, CLIO always evaluates harmonics from second to fifth and allows the display of each one separately via its own push buttons. While it is simple to obtain meaningful distortion figures of electrical devices, measuring Loudspeaker distortion in normal environments (without anechoic chamber) is not easy. We will only give some advice here, relying on examples, as the topic is far beyond the scope of this User Manual. To do this we will use CLIO's FFT Menu in quite an advanced way. Distortion evaluation is adversely affected by several parameters, two of which are the most important.

Noise

50 dB SPL of ambience noise, a common figure, usually does not affect Amplitude evaluation which is usually carried out at an average level of 90 dB SPL. This is particularly true using CLIO Sinusoidal Analysis capability which, by means of DSP filtering, allows exceptional S/N Ratio. Unfortunately evaluating 1% distortion means looking for signals that are 40 dB lower than the 90 dB SPL mentioned above, in the same order of magnitude as environment noise.

Gating Effects

Device settling time, non perfect delay removal and reflections arriving within the sampling time (Meter On) seriously affect distortion measurements, creating artifacts.

It is advisable to perform a noise evaluation using FFT Analysis. Fig. 9 shows two curves, the first (red) is obtained with the Max Hold function, the second (black) with Min Hold.

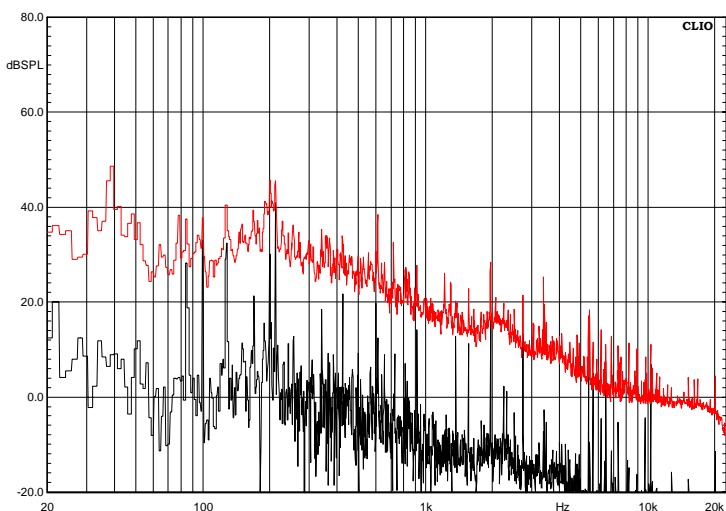


Figure 11.8

The first, a sort of worst case, should be taken as the reference lower distortion floor once raised 10 dB at least. The second is useful to identify pure tones in the noise spectrum; these are likely to produce both distortion increase as well as cancellation artifacts. In our case these tones are caused by more than 20 different computer fans, spread everywhere in the room. Supposing we carry a distortion analysis at an average 90 dB SPL, residues below 1% are difficult to evaluate up to 600 Hz, things are much better at higher frequencies. Remember that the frequency axis should be referred to the harmonic we are looking for, not to the fundamental. The obvious solution to overcome noise is to increase the level. One way is to put more voltage at the Loudspeaker terminals; unfortunately this increases distortion by itself even if it provided important information regarding the device. The second way is to narrow the

Microphone to Loudspeaker distance. The next figures, dealing with Gating Effects, refer to a Microphone at 11.5cm (4.5") in front to a good quality tweeter. FFT size is set to 512 points, the equivalent of about 10ms Meter On at 48000Hz sampling rate. Fig.11.9 shows the effects of a wrong delay in capturing a 2kHz 10ms tone burst. All harmonics are buried below the effects of this wrong setting.

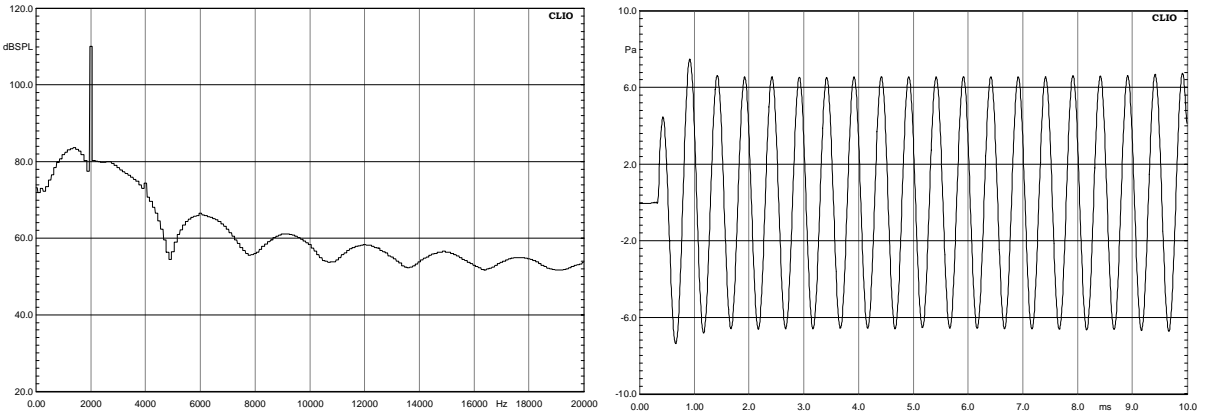


Figure 11.9

Fig.11.10 shows the effects of the device settling time as the delay is now correctly set to 0.35ms. 40dB down the harmonics (1% distortion) should be visible now. As the tweeter performs better than this what we see is the second harmonic canceling the broad spectrum caused by the device settling time.

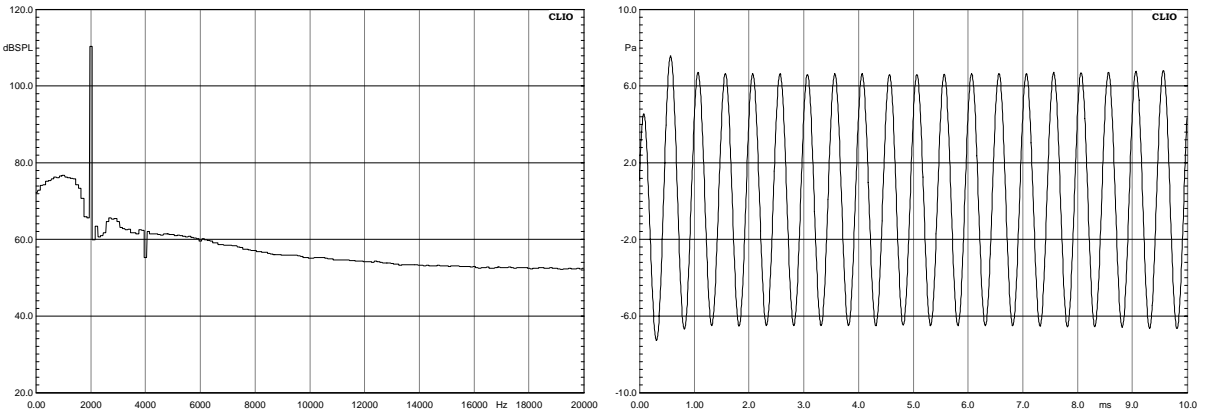


Figure 11.10

Fig.11.11 shows the spectrum when the delay has been set to 1.5ms. The third harmonic, 64dB (0.06%) below the fundamental is clearly visible.

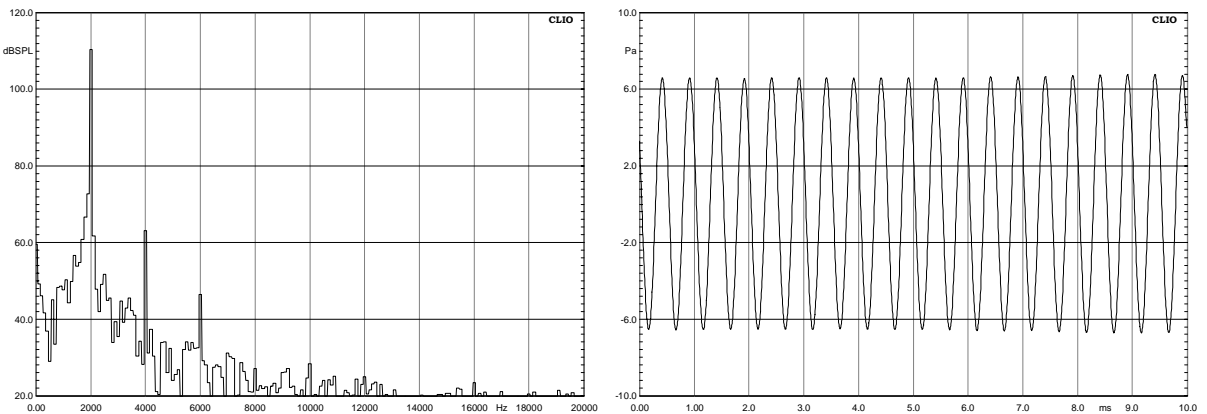


Figure 11.11

Finally Fig.11.12 shows the distortion analysis carried out with the same microphone distance as in the past examples and the gating delay set to 1.5ms with the auto delay option disabled. Fundamental is red, second harmonic (+ 30dB) blue and third harmonic (+ 30dB) green.

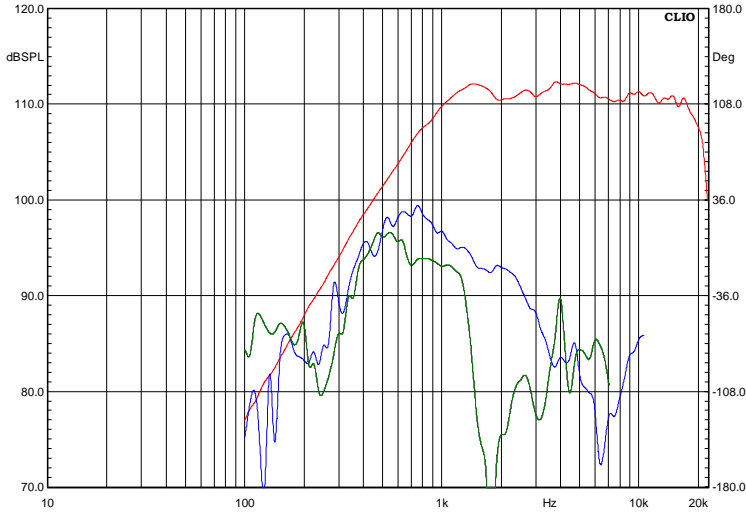


Figure 11.12

12 WATERFALL AND DIRECTIVITY

12.1 INTRODUCTION

The Waterfall and Directivity post processing routines give CLIO the possibility of making 3-D or Color plots by adding a third dimension (time or degrees) to classical amplitude-frequency graphs.

Waterfalls are used to characterize the anechoic sound decay of a loudspeaker or the sound decay in a room.

The Waterfall post processing permits the following 3-D or Color types of analysis:

- **Cumulative spectral decay (CSD)**
- **Energy Time Frequency (ETF)**

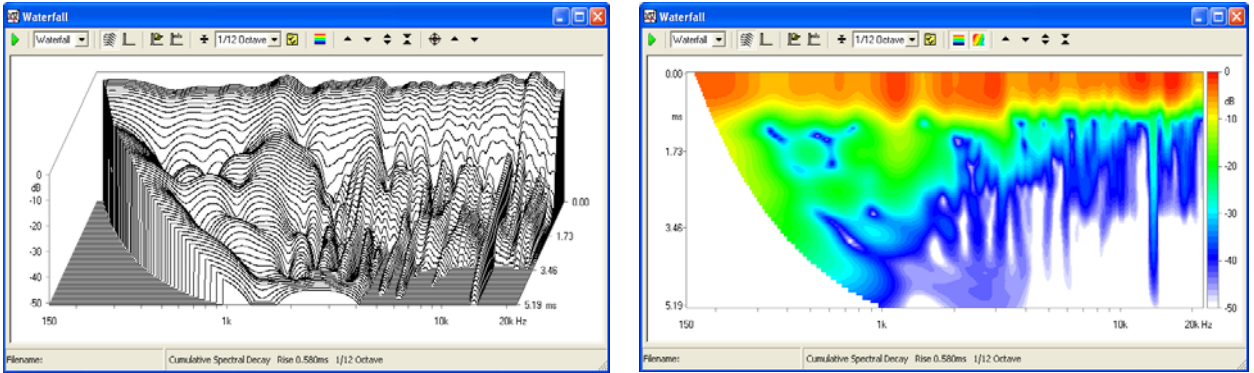


Figure 12.1

Directivity analysis characterizes the radiation of a loudspeaker versus vertical or horizontal angle.

The Directivity post processing permits the following analysis:

- **3-D directivity (waterfall like)**
- **Color map directivity**
- **Classical polar plots**

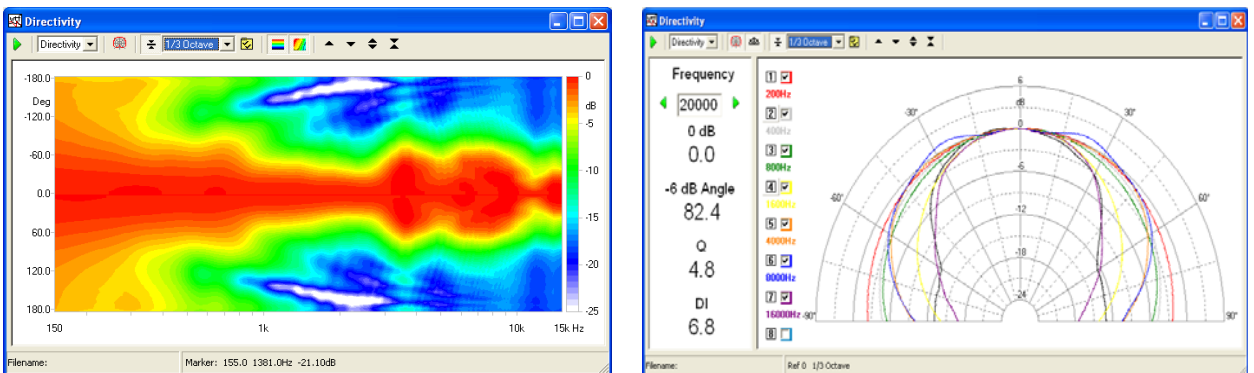


Figure 12.2

12.2 WATERFALL AND DIRECTIVITY CONTROL PANEL

Fig 12.1 and 12.2 show the Waterfall and Directivity control panel in many of its possible configurations; as you may imagine the post processing capabilities of this menu are very powerful.

It is important to understand which is **the source of data** for the waterfall and directivity analysis.


Waterfall

A waterfall analysis is a post process applied to a measured **impulse response**. Please refer to chapter 10 (MLS&LogChirp) to have details on how to measure an impulse response.

Directivity


A directivity analysis is a post process applied to a **set of measured frequency responses**. Please refer to chapters 9,10 and 11 (FFT, MLS&LogChirp and Sinusoidal) to have details on how to measure a frequency response.

12.2.1 COMMON TOOLBAR BUTTONS AND DROP DOWN LISTS

 Starts a waterfall or directivity calculation.

Analysis drop down

Selects either Waterfall or Directivity analysis.


 If pressed the waterfall spectra will be referenced to the rearmost one; the directivity spectra will be referenced to the one identified by the Z-Ref value (see 12.5.1)

Smoothing drop down

Selects the smoothing factor in fractions of octave.

 Enters the settings dialog. See 12.3.1 and 12.5.1.

 Displays a color map instead of 3D plot.

 Interpolates colors in order to obtain smooth level contours.

 Moves the plot up.

 Moves the plot down.

 Expands the plot changing its Y scale. The Y range is reduced.

 Compresses the plot changing its Y scale. The Y range is increased.


12.3 WATERFALL SPECIFIC CONTROLS


 When pressed the waterfall plot is displayed.


 When pressed the impulse response loaded in memory is displayed.

 Loads an impulse response from disk (from MLS binary files).

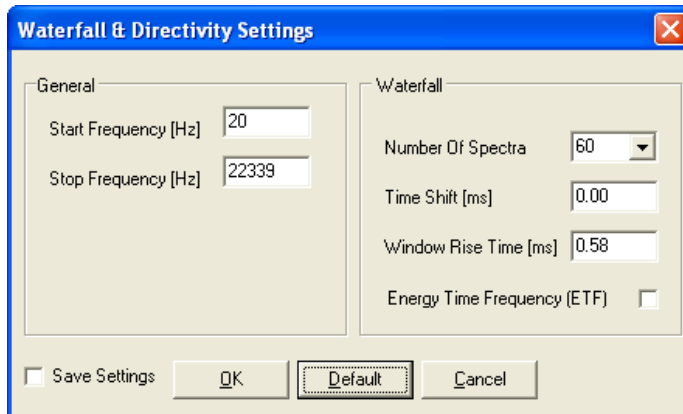
 Takes current MLS impulse response for waterfall calculation.

 Enters the Marker mode (see Fig. 12.5). In this operating mode it is possible to inspect the single data points of each waterfall slice by clicking and dragging the mouse.

 When in marker mode, moves the selected waterfall slice backwards. The same action is obtained with the **Up-Arrow** keyboard shortcut.

 When in marker mode, moves the selected waterfall slice frontwards. The same action is obtained with the **Down-Arrow** keyboard shortcut.

12.3.1 WATERFALL SETTINGS



Start Frequency

Selects the start frequency for the analysis.

Stop Frequency

Selects the stop frequency for the analysis.

Number of Spectra

Selects the number of data slices to display.

Time Shift (ms)

Selects the time between two consecutive spectra.

Window Rise Time (ms)

Selects the rise time of the data selecting window. Valid only for CSD.

Energy Time Frequency (ETF)

Selects ETF mode waterfalls.

12.3.2 WATERFALL OPERATION

As already stated, the data source for a CSD or ETF waterfall is a measured impulse response

Once you have loaded an impulse response inside the Waterfall control panel you may easily inspect it, in the same way you also do with the MLS Impulse control panel (see chapter 10). Of great importance is to select the start time and stop time of the analysis: **start time**, the Start Window value selected in the impulse response represents time zero for the waterfall; **stop time**, the Stop Window value selected in the impulse response represents the last processed CSD slice unless a different Time Shift has been selected.

CSD (**Cumulative Spectral Decay**) is intended primarily for anechoic loudspeaker evaluation; in this case only the data between the start and stop time is analyzed; each successive slice considers time data from its relative start time (the rearmost, at time zero, has start time equal to the start window of MLS) to the fixed stop time, the data being windowed by a particular time window with a smoothed rising edge (see literature for a discussion about this). Normal values for the Window Rise Time lie within 0.1 and 0.6ms. In CSD mode, should the Time Shift value be left at zero, the routine will automatically calculate it, spacing the selected Number of Spectra in the interval defined by start and stop times; if Time Shift is forced by the user be sure to set it small enough to permit the last spectra to be calculated; if the fixed stop time is passed, then the calculation defaults as in case of zero Time Shift.

When representing a CSD the program automatically hides the low frequency part of the spectra that has become unreliable due to the time-frequency uncertainty principle.

ETF (**Energy Time Frequency**) is intended for room acoustic evaluation; in this case all MLS data starting from the start time are computed; then, successive slices are calculated moving their initial point of the Time Shift value (see 12.3.1 the Settings dialog).

12.4 MAKING A CUMULATIVE SPECTRAL DECAY

A cumulative spectral decay starts loading an impulse response from disk. Suppose we have taken an anechoic response of a medium sized two ways loudspeaker; the impulse response is shown in Fig.12.3.

Let's first select a reflection free part of it. By selecting the start and stop window points we obtain the first two information parameters required for the waterfall facility: zero time will be referenced to the start of the start window, while the Z axis will provide the measurement range between the stop and start window points (unless a Time Shift is chosen).

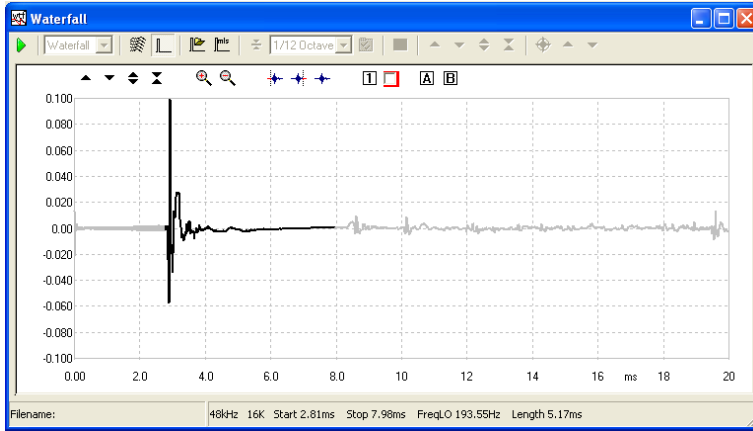


Figure 12.3

Going inside the Waterfall Settings dialog we decide to view our measurement between 150 and 20000Hz, then apply 1/12 octave smoothing. We are now ready for a waterfall!

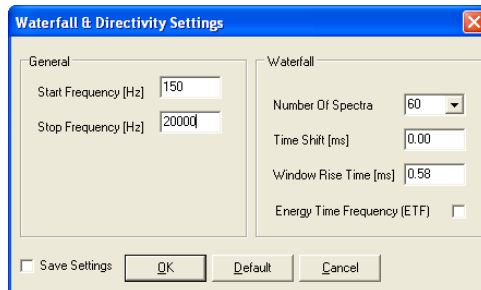


Figure 12.4

The Go button is enabled. Press it, you should obtain a waterfall like the one in the left part Fig. 12.5. Press now the Color Scale button followed by the Interpolate Colors buttons, now you should have the color map shown in the right part of Fig. 12.5. The two representations are not exclusive, they mutually complement each other; you will gain experience understanding all the subtle details of a waterfall processing and how they are represented either in the 3D or in the color map. For example the color map represents better the frequency of decaying modes as they result as straight color patterns parallel to the time axis; the 3D waterfall is more familiar when you look at zero time frequency plot and try to visualize how it modifies during decay.

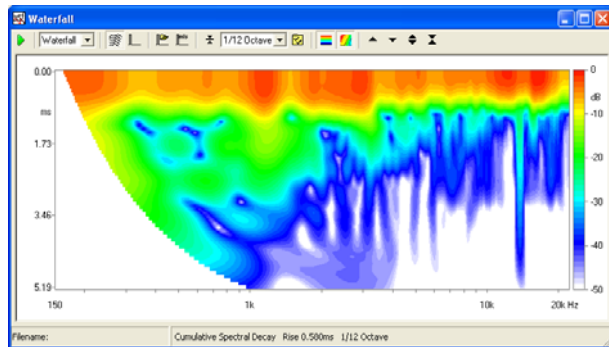
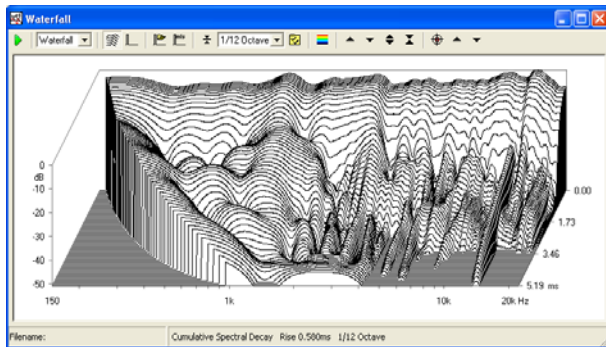



Figure 12.5

One powerful way to inspect a waterfall is to enable its marker. Press the  button. The display should change as in Fig. 12.6. It is very easy to locate frequency zones where the decay 'suffers', like the peak around 2200Hz. After placing the cursor on it, it is possible to quickly move back and forth the calculated slices by means of the up and down keyboard arrows.

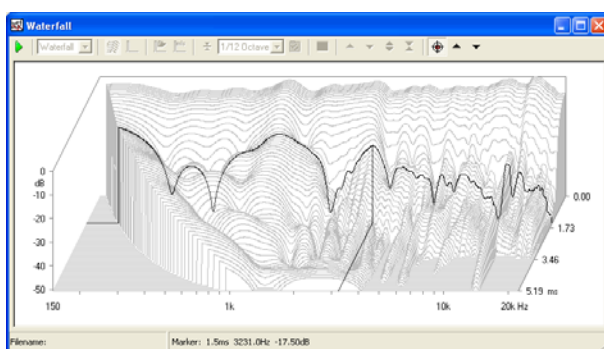


Figure 12.6

Let's now change the CSD aspect. Go to the waterfall settings dialog and input 0.1ms Time Shift. After recalculating it you obtain the plot in Fig. 12.7; as you now notice the slices are closer in time and decaying modes are more evident. Since the time span chosen for this waterfall was about 6.1ms the maximum allowed Time Shift you could input was around 0.2ms (considering 30 spectra as in this case).

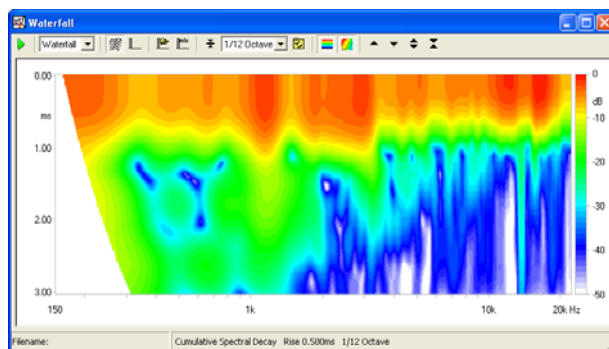
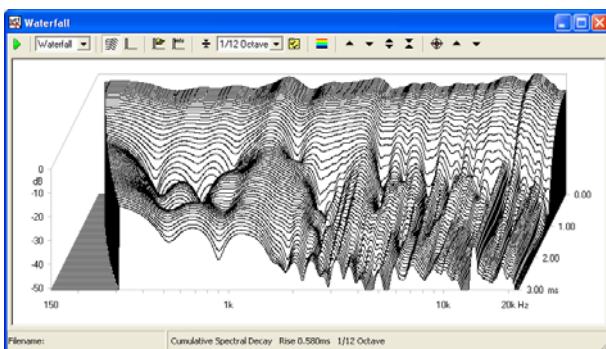


Figure 12.7

Let's now change the CSD aspect again. Go to the waterfall settings dialog and check the Reference box. After recalculating, you obtain the plot in Fig. 12.8

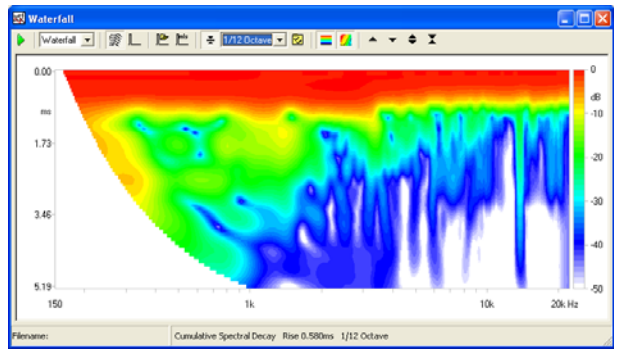
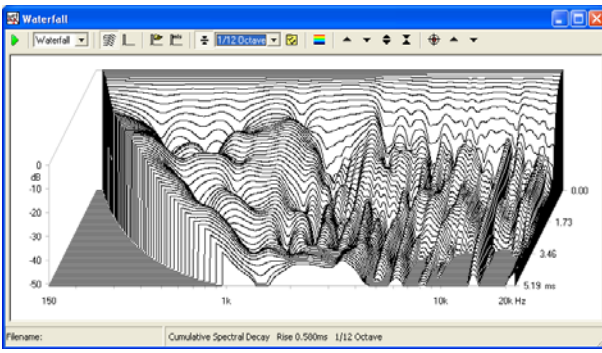


Figure 12.8

As you can now see the slices are referenced to the first one (the rearmost); thus allowing decays of different frequency regions to be compared more easily.

Now change the Windows Rise Time from the default 0.58ms to 0.1ms and recalculate the CSD. The result is given in figure 12.9.

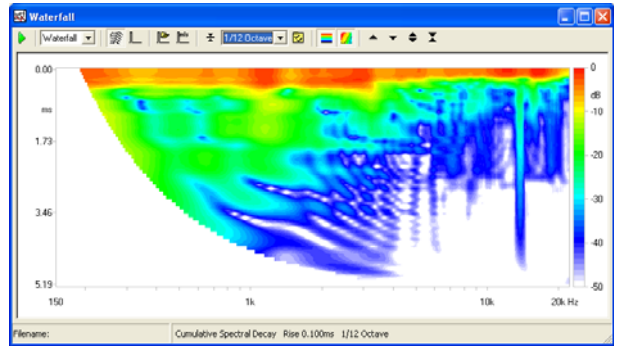
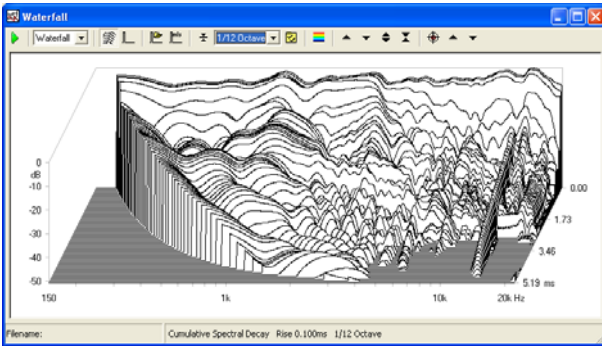



Figure 12.9

12.5 DIRECTIVITY SPECIFIC CONTROLS

 Enters the polar pattern mode.

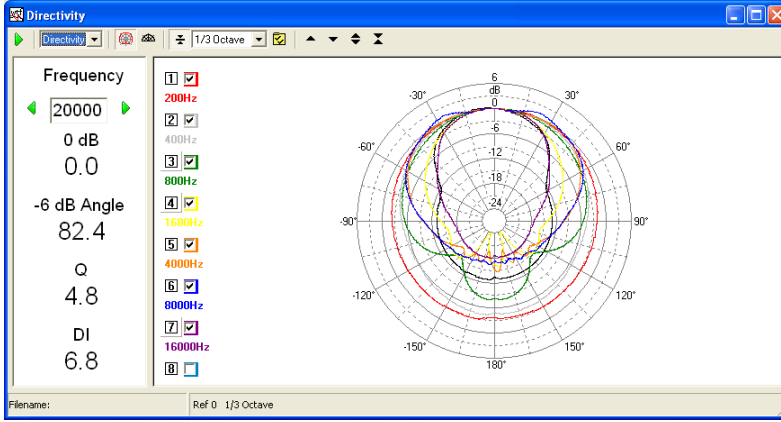



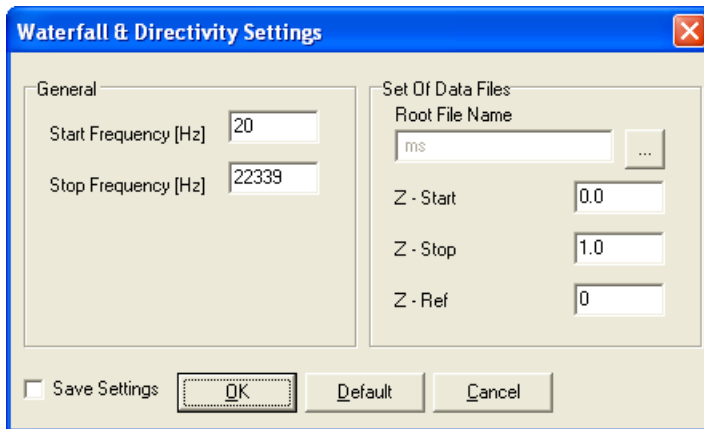


Figure 12.10

-  When in polar pattern mode moves analysis frequency up 1/3 of octave.
-  When in polar pattern mode moves analysis frequency down 1/3 of octave.
-  Selects an half space polar pattern. Refer to the right Fig.12.2.

12.5.1 DIRECTIVITY SETTINGS AND OPERATION



Start Frequency

Selects the start frequency for the analysis.

Stop Frequency

Selects the stop frequency for the analysis.

Root File Name and browse button

The name of one file within the set to be displayed. By pressing the associated button it is possible to browse the disk and choose the file.

Z-Start

Value associated to the first (rear-most) file.

Z-Stop

Value associated to the last (foremost) file.

Z-Ref

Value associated to the file to be taken as reference.

The radiation characteristics of a loudspeaker or driver versus frequency and angle rely on a huge amount of data i.e. a set of frequency responses (taken at different angles on the vertical or horizontal planes) saved to disk; for example it is common to work with sets of 72 files representing the frequency response taken at 5 degrees angles to represent a complete rotation in a plane.

With the directivity analysis you get a powerful way for synthesizing a large number of measurements in a single color map or 3-D graph. This control panel allows the representation of the classical **polar response** of a loudspeaker as in Fig. 12.10.

In order to identify the set of files it is important that all of their names follow a particular syntax, that gives certain information to the processing routines.

The syntax follows: **<NAME><UNITS><VALUE/100>.MLS.**

NAME is a common file name, UNITS are the common measurement units (to be displayed in the graph as Z axis label) and VALUE is a unique value identifying the single file; these quantities needs to be separated by **spaces**, it is possible to give negative numbers to VALUE. For example '**mydriver deg -250.mls**' is a valid file name: as the name tells it is a measurement named **mydriver** with units **deg** taken at **-2.5** (250 divided by 100) units value. If the units are not specified within the name then the processing defaults to **deg**.

The autosaving and naming capabilities of CLIO render the job of measuring and creating a complete directivity data set an easy and automatic task (see later 12.6 for an example).

It is possible to identify one file within the set as the reference with the Z-ref value; when in reference mode all calculations will then be done referenced to it.

12.6 MEASURING AND REPRESENTING LOUDSPEAKER POLAR DATA

Now suppose we want to measure and give a graphical representation of the polar response of the same two ways loudspeaker analyzed in 12.4.

We need to measure its anechoic frequency response, at various angles and save the files following the rules given in 12.5.1.

We will use a PC controlled turntable (Outline ET/ST), under CLIO's control, and the automation possible within the MLS control panel using the Autosave and naming rules.

12.6.1 PREPARING AUTOSAVE AND THE MLS CONTROL PANEL

For this test we would like to measure the speaker from -180° to $+180^\circ$ (in intervals of 5°) relative to its front baffle.

The MLS measurement should be set in a particular way in order to automatically acquire the responses at various horizontal angles. **To do this we will use the autosave function, the loop mode and the link to the turntable control.**

Let's start with setting the autosave function (see also 5.3). Pressing **Alt-F2** we recall the Autosave Setting dialog (fig.12.11); here we input the desired filename ('RogersHalfChirp'), start (-180) increment (5) and total (73) values.

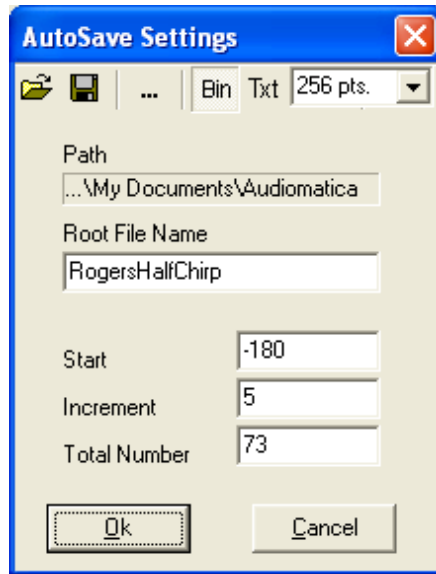


Figure 12.11

The MLS menu is now ready to start taking measurements; we only need to properly set the turntable and its control.

12.6.2 PREPARING THE TURNTABLE

We assume that the Outline turntable is properly connected to your PC (refer to 4.5.2 for details). To prepare for this measurement session you need to:

- 1) Manually set the front selector labelled 'Deg Step' to 5° .
- 2) Rotate the turntable counterclockwise until you reach the desired start position: as we want to start from -180° position it at 180° .
- 3) Recall the turntable control dialog (Fig.12.12), set Resolution at 5° , Speed at 0.75 RPM and press Link To Measurement

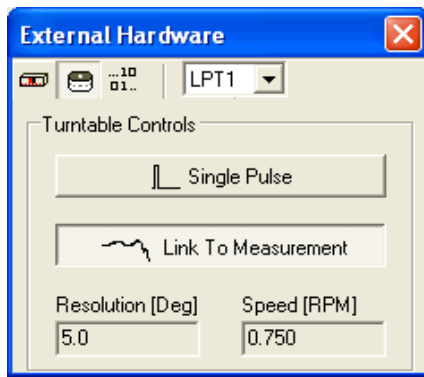


Figure 12.12

12.6.3 TAKING THE MEASUREMENTS

You are now ready to begin the measuring session. We suggest you to take an initial measurement (with the speaker in place over the turntable) to verify all the parameters, especially viewing the acquired impulse response and setting the start and stop values of the measurement window. These values will be applied to all the measurements taken; consider, in this respect, the problem of the trajectory of the acoustic center of the speaker during the rotation.

The last thing to do is to activate Autosave and Loop; to do this we press the corresponding toolbar buttons (Fig.12.13).

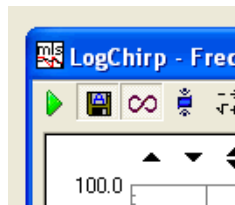


Figure 12.13

Press Go. After each MLS measurement is taken you will see the turntable rotating and CLIO waiting for a sufficient period of time to allow the turntable to stabilize before automatically taking the next measurement. Should this time be insufficient you have to reset the turntable speed value accordingly. The autosave function will refresh the filename after each measurement (Fig.12.14).

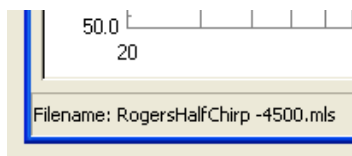


Figure 12.14

After the 73 measurements are taken the session should end while the autosave and loop buttons reset.

12.6.4 REPRESENTING POLAR DATA

To represent the measured data we need to enter the Directivity Settings dialog and press the browse button. Entering our data directory we find the situation in Fig. 12.15:

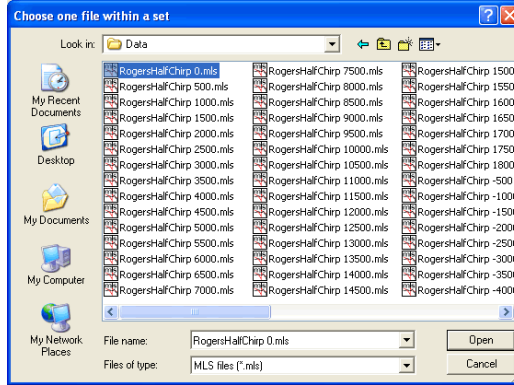


Figure 12.15

The set of files is composed by 73 files; it is sufficient to choose one of them. It is now important to identify the initial and last files for display, this is done with the Z-start and Z-stop values to be input as in Fig.12.16. We choose to display all responses from -180° to $+180^\circ$, take the response on axis as reference and choose frequency limits from 150Hz to 15KHz.

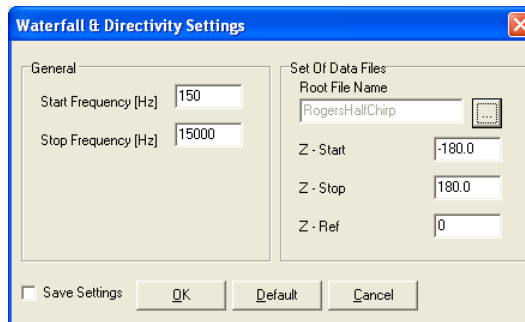


Figure 12.16

We are, at last, ready to start a directivity analysis.

The results are in Fig. 12.16 both as color map and 3-D plot.

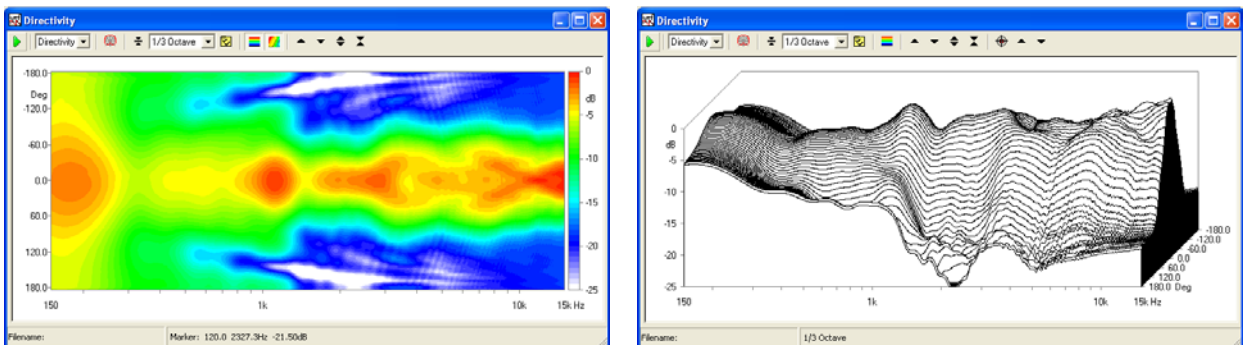


Figure 12.16

Treating polar data we may be more interested in referencing the graph to the response that our speaker shows on-axis. This is easily done pressing the reference button and executing the processing again.

The final result for our polar data waterfall is in Fig.12.17; the response at 0 degrees is now flat and our plot perfectly identifies the behavior of the speaker, providing clear evidence of the different behavior of the polar response versus different frequency zones.

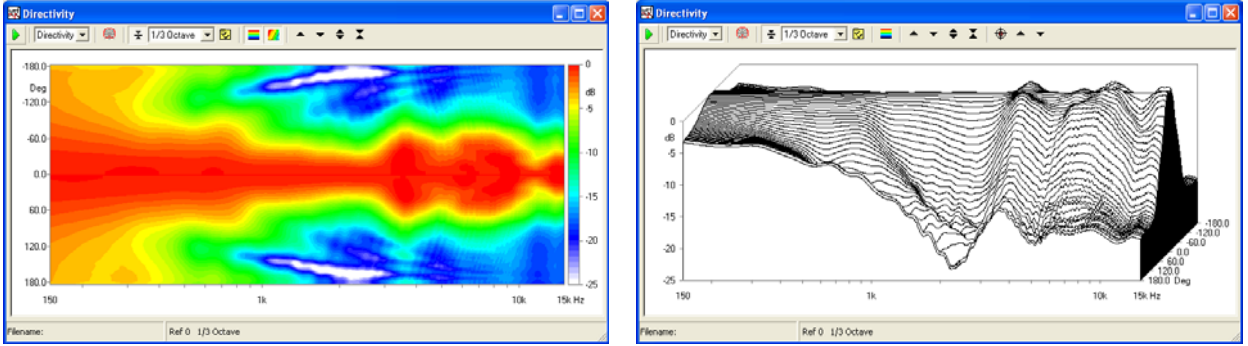


Figure 12.17

Another way to view the same data are the classical circular polar plots. To achieve this ulterior result simply press the Polar Pattern button. Then you may change analysis frequency with the dedicated arrow buttons and save the polar patterns of interest in different overlays reaching a situation like the one in Fig.12.18.

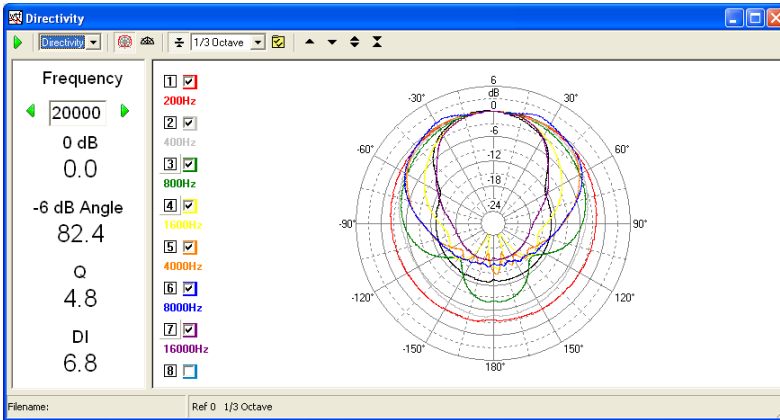


Figure 12.18

13 MEASURING IMPEDANCE AND T&S PARAMETERS

13.1 INTRODUCTION

This chapter deals with impedance measurements generally before going onto the Thiele and Small Parameters Menu description. CLIO performs impedance vs. frequency measurements both from within the MLS and the Sinusoidal Menu. You will find specific information in the relative Chapters. Both are relevant to what we will now explain. Here we explain connections, principles and other topics that apply to both menus. Differences and choice criteria are also covered.

13.2 GENERALS

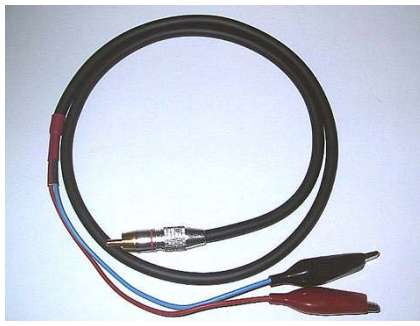
Whatever the stimuli, CLIO sees a voltage at its input. Impedance is obtained by a suitable post process, which changes depending upon how the user decides to perform the measurement. Four methods are available. Two of them, **Internal** and **I Sense**, were already found in the Settings Dialog, both in MLS and Sinusoidal. We will start with these, leaving **Constant Voltage** and **Constant Current** to later on. The last two methods derive their name from the description of what is going on during the measurement; they were the standard before automatic computer based Measuring Systems. **Internal** and **I Sense** are faster, requires only one measurement, and handles the connections needed much more easily.

13.3 INTERNAL MODE

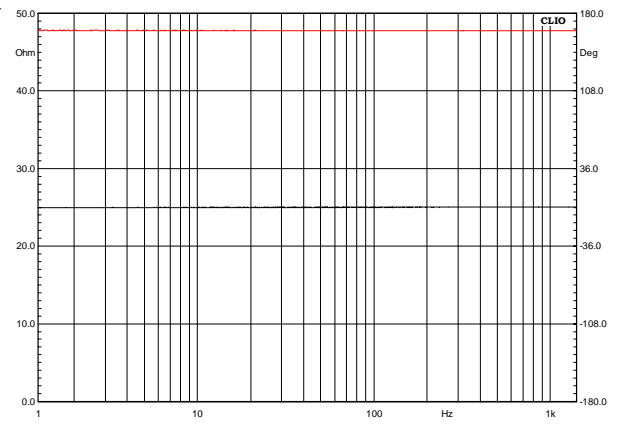
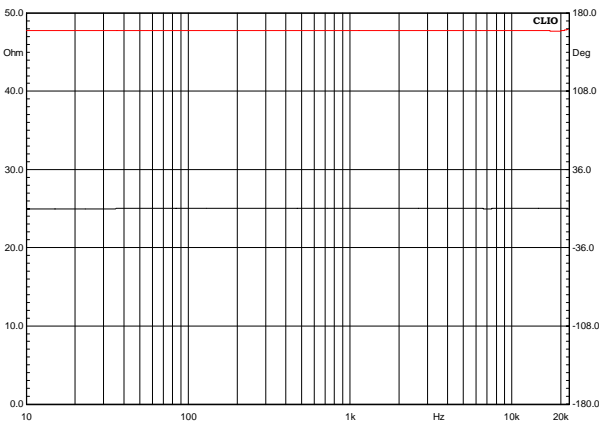


Figure 13.1

In principle, internal mode is very similar to **Constant Current**. It takes advantage of the knowledge CLIO has of its own output level and output impedance (150 Ohm 0.1%). In fact, this value is lower than what should be used for a true Constant Current procedure. Veterans should not worry: even if the resistor value is on the same order of magnitude as the device you are going to measure instead of 10 times higher as usually advised, no errors occurs as CLIO is able to acquire and evaluate the signal as a complex signal (real and imaginary) at the device terminals. Fig.13.1 shows the connections for measuring Impedance in Internal mode. Only one cable (pin-to-alligators like the one in the photo) is needed, without any other external active or passive devices. Before starting any impedance measurement in Internal Mode remember **to switch on the loop button** (🔌 or 🔌) of the channel you are going to use.



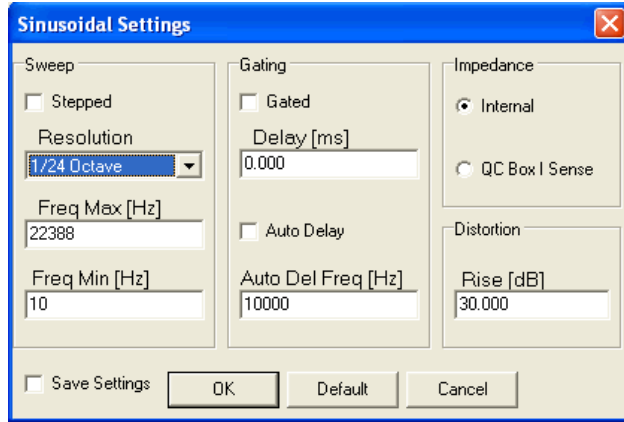
If you are a novice in using CLIO, or to impedance measurements in general, use this mode; also do not start measuring loudspeaker impedance immediately. Get a 22 to 100 Ohm resistor, possibly 1% tolerance, and gain experience with something which you should already know the expected results of. Here are two examples both with Sinusoidal and MLS. Before you press go, remember to set the Y scale to Ohm. For this example we chose a 47 Ohm resistor. The modulus should be very close to the resistor value (red curve) and equally important, the shown phase should be very close to 0; these results should cover the entire frequency range. Notice that Fig. 13.3, which refers to MLS, extends low frequency limit to 1Hz while Sinusoidal, Fig. 13.2, stops at 10Hz which is the lowest possible. If you are not getting similar results do not proceed with a loudspeaker impedance measurement. To do so would only add problems later by using an inaccurate working procedure, as we will soon see. Even in internal mode CLIO's output level is left to the user. We set it at +10dBu here as resistors are, hopefully, the most linear devices we can get. Since we had very comfortable results lets proceed with a Loudspeaker.



Figures 13.2 and 13.3

13.3.1 MEASURING IMPEDANCE OF LOUDSPEAKERS

We will start with a 5" woofer using Sinusoidal, **our preferred choice**, with the following Settings.



Besides frequency range, which can be changed without side effects, those above are problem free settings for impedance measurements. We will experiment a little, pointing out difficulties that might arise. Let's start with output level, which is a sensitive topic.

13.3.2 SETTING THE RIGHT LEVEL

The five curves of Fig.13.4 are taken at 5 different output levels, ranging from 10dBu to -10dBu in 5dB steps. The red curve refers to +10dBu, the blue to +5dBu, the remaining are substantially overlapped.

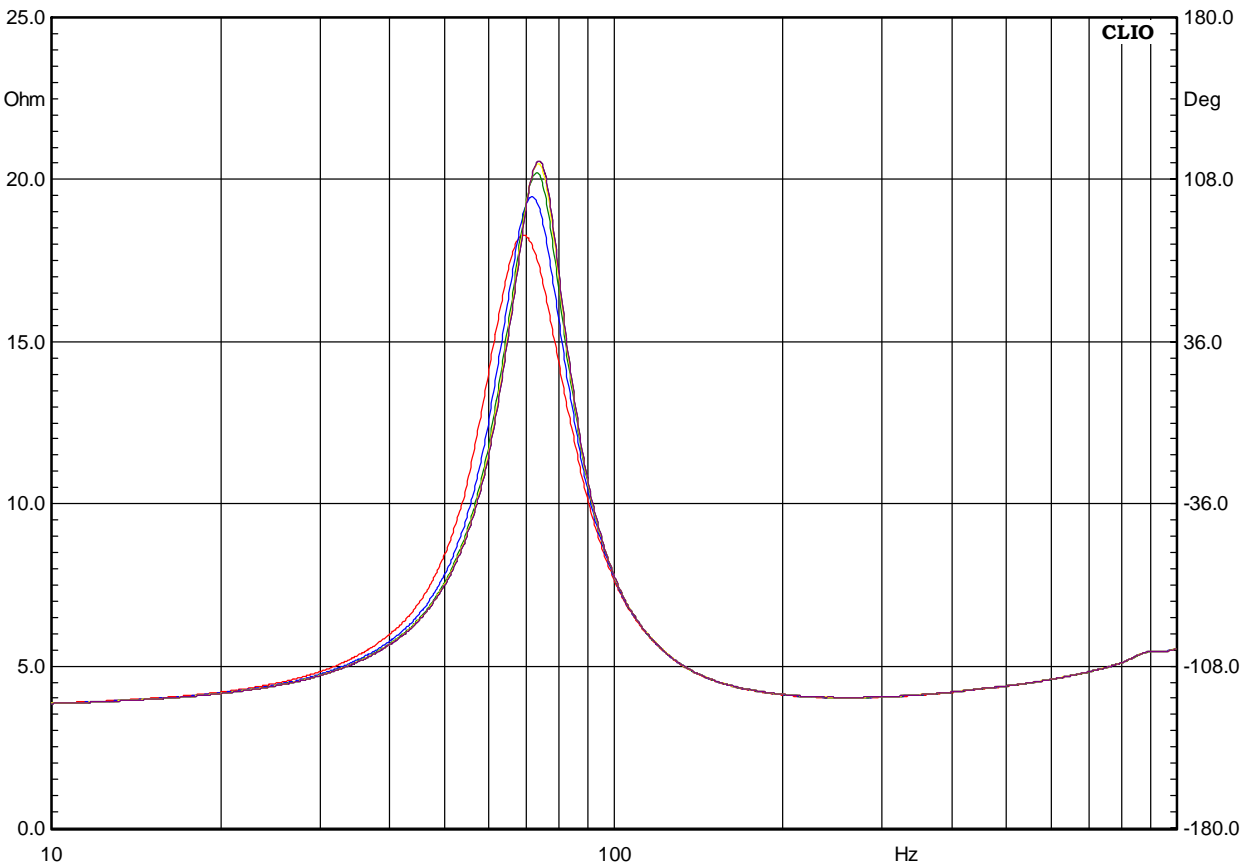


Figure 13.4

It turns out that going from a linear device such as our resistor to loudspeakers makes

life harder even if more interesting. Deriving the principals T&S Parameters from the five curves yields to Table 13.1

	Fs	Qms	Qes	Qts
+10dBu	69.244	3.105	0.609	0.5094
+5dBu	71.63	3.6461	0.6643	0.5619
0dBu	72.9912	3.986	0.695	0.5920
-5dBu	73.5429	4.1663	0.7147	.61
-10dBu	73.82	4.227	0.7218	0.6166

Table 13.1

Values from 0dBu to -10dBu are in optimum agreement and this sets the maximum level to be used to 0dBu. Interestingly enough, **Internal Mode** is less sensitive to output level. We will go further into this topic relying on CLIO being a complete and powerful audio measuring system. Without changing connections we will use CLIO's FFT and Signal Generator to evaluate the distortion current at resonance at 10dBu. Fig.13.5 shows the spectrum in this condition. The second harmonic is 56dB lower than the fundamental, which is 0.158% distortion. Even at 10dBu we are easily in the linear region of the loudspeaker motor. However what we have seen above, clearly states 10dBu is quite a high level for this device.

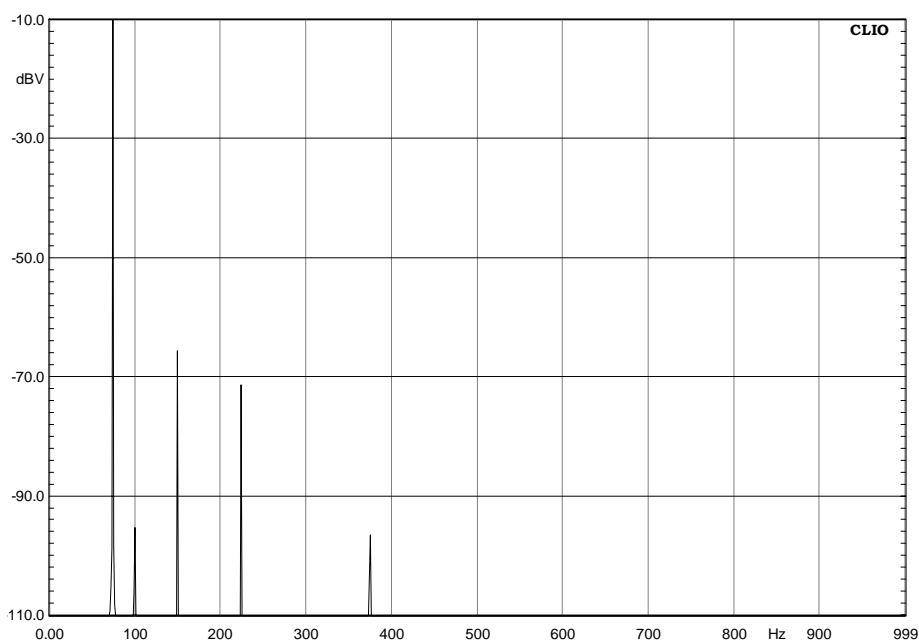


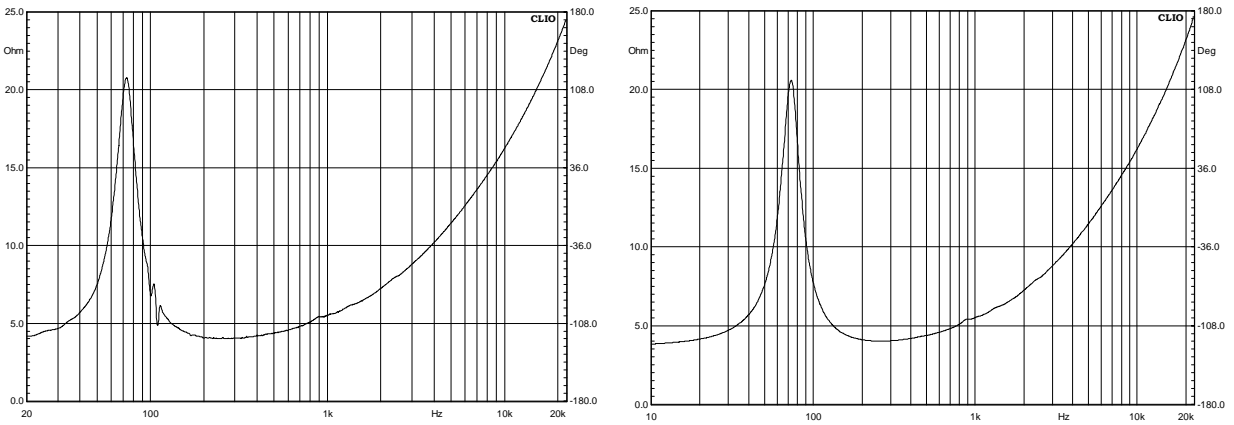
Figure 13.8

The reader could be tempted to determine the absolute quality of the device by means of this procedure. While he or she may be right, a lot of experience is needed. One important parameter, for reliable comparison among devices, is the value, in VRMS, at the speaker terminals at resonance. It is shown from FFT as -10dBV that is 0.316VRMS.

13.3.3 DEALING WITH ENVIRONMENTAL NOISE

The next problem in measuring loudspeaker impedance is noise. Transducers do their job in both directions and noise will appear as voltage exactly where CLIO's input is connected. To evaluate the problem we deliberately produced a disturbance by generating a 110Hz single tone causing 58 dB SPL at the speaker cone. We took two impedance curves in this condition one with MLS the second with Sinusoidal. Both were

taken at -10dBu, a value that gained our favor before. Results are in Fig.13.6 for MLS and Fig .13.7 for Sinusoidal.



Figures 13.6 and 13.7

This is one reason why we prefer sinusoidal analysis to measure impedance.

13.3.4 DEALING WITH VIBRATIONS

The last enemy we must consider is external vibrations.

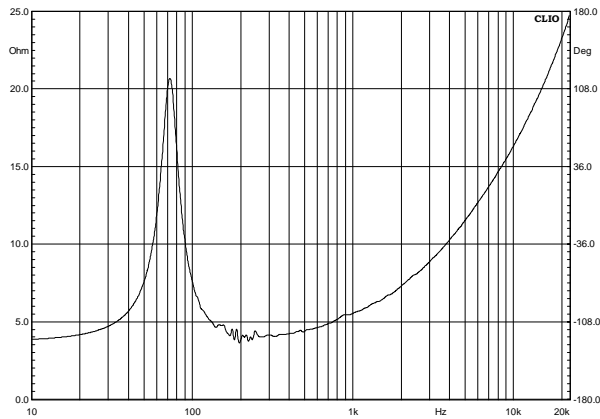


Figure 13.8

Fig.13.8 is an impedance curve taken with the loudspeaker positioned on a computer table, on one of those appendages that may be set up or down upon needs. This support clearly resonates, excited by the loudspeaker, at around 200Hz. No matter how good the loudspeaker is fixed to a structure if the structure itself moves then potential problems may become apparent. Usually there is no need to fix anything as long as you are using a stable, non-resonating structure.

Up to now we have dealt with Internal Mode. We will briefly go through the others modes; problems found up to here will remain the same or worsen from here on!

13.4 I SENSE

This requires Audiomatica CLIOQC Amplifier and Switch Box model 2, 3 or 4. It is a simplified Constant Voltage method. Simplification arises as both device gain and sensing resistor (around 0.1 Ohm) is known. Fig.13.9 shows the CLIOQC Software Control Dialog Box. I Sense should be selected.

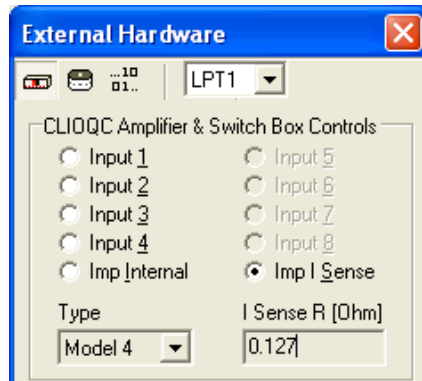


Figure 13.9

Fig.13.10 shows required connections.

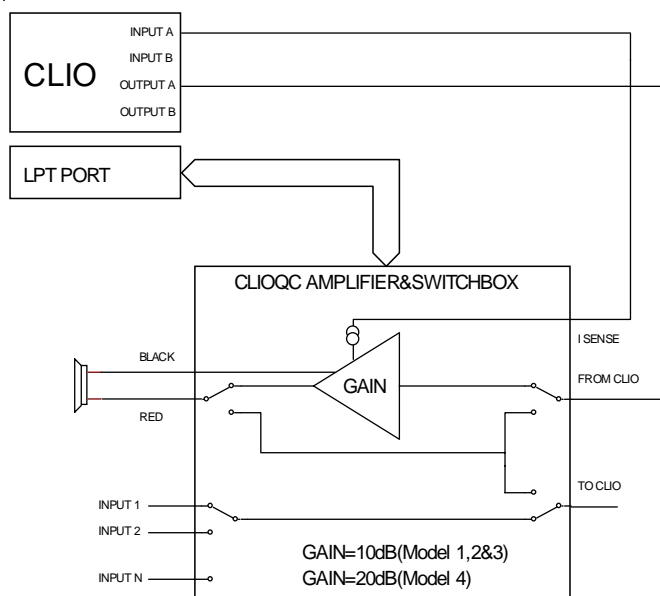


Figure13.10

Before proceeding, whether in MLS or Sinusoidal, remember to go into the Settings Dialog and select I Sense under Impedance. CLIO's output level has to be set to a much lower level than in Internal Mode. We have seen before that with 10dBu out we had 0.316V at the speaker terminals at resonance. Should you keep this level you would have 7.75V at any Frequency! -20 to -30 dBu are reasonable output levels to start with. The CLIOQC Amplifier gain is 10dB (Model 2&3) or 20dB (Model 4); it therefore multiplies CLIO's output by 3.16 (Model 2&3) or 10 (Model 4). As the output impedance is close to 0 no further attenuation occurs once the speaker is connected. Finally we shall deal with measuring accuracy in this case. The sensing resistor value has been stated as around 0.1 Ohm. It is very difficult to keep such a low value within a reasonable tolerance and therefore the real value is going to change between units. The default value that is used is 0.127 Ohm. The user can further adjust this value using a reference resistor of known value in the 10 Ohm range (the real value can be eventually measured with high accuracy using the internal mode). Simply take an impedance measurement of the known resistor and adjust the I Sense value displayed multiplying it by the ratio

between the known resistor value and the marker reading at 1kHz. For example: assume a known resistor value 10 Ohm, reading at 1kHz 9.3 ohm and an I Sense value of 0.127 Ohm. Multiply 0.127 by 1.075268817 to obtain 0.13655914, input this new value and check everything by performing a new measurement.

13.5 CONSTANT VOLTAGE & CONSTANT CURRENT

These were the standard approaches to measuring impedance with a traditional set of instruments. We will skip further theoretical discussion and go directly on how CLIO implements them. Both these methods require two external components, a reference resistor of suitable and known value (where known means better than 1% tolerance) and a power amplifier. They also require two measurements to be taken one after the other, changing connections in between. CLIO, by means of its processing tools can speed things up a lot but the whole procedure remains quite complicated. Whatever you are going to use, MLS or Sinusoidal, all the measurements should be performed in Volts (the Y Scale should be dBV).

13.5.1 CONSTANT VOLTAGE

Proceeding step by step we are going to create two files, one named "reference", the second named "device". The two measurement files must have identical settings and identical CLIO's output level. We choose a sensing resistor, R_s , of 1 ohm at 1% tolerance. Fig.13.11 shows connections for creating the reference file. The level you choose now is the total measuring level.

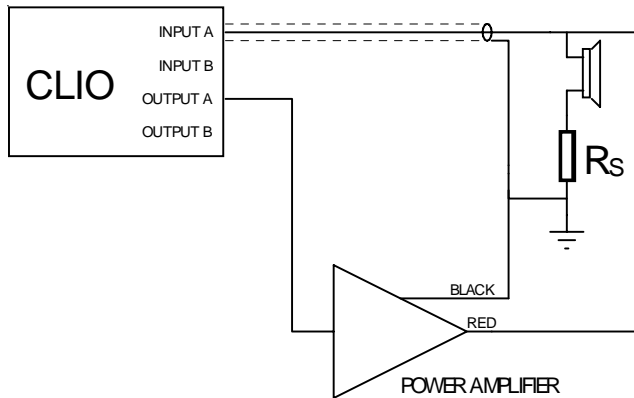


Figure 13.11

The reference measurement is shown in Fig 13.12. As expected the output of the amplifier appears as a straight line. Should this not be so, this would not be a problem as the whole procedure compensates for any deviation in the frequency response. More interesting is the absolute level. As the R_s value is small, this level appears nearly unchanged to the speaker. We read -12dBV that translate in 250mV.

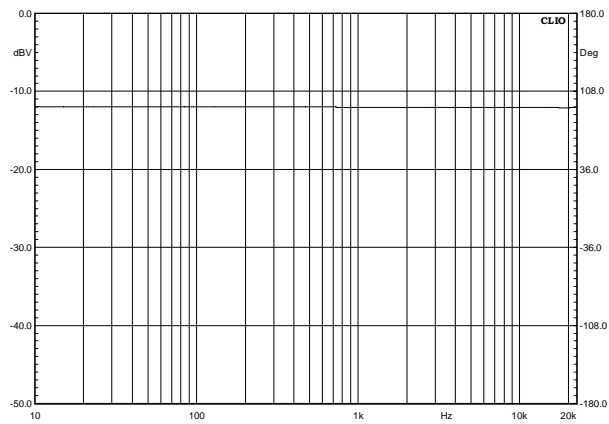


Figure 13.12

Let's now proceed with measuring the device. Connections need to be changed as in Fig. 13.13. We are now going to measure the voltage across R_s , which is proportional to the current in the device. Leaving everything in the Sinusoidal menu as it was for the previous measurement we obtain Fig.13.14. It seems a strange shape if you are not used to. But in fact we are measuring Current here and, Voltage being constant, it decreases at resonance (from Ohm's law $I=V/R$).

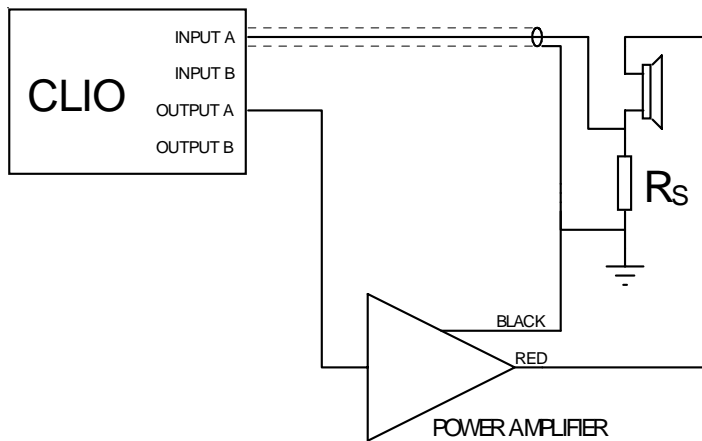


Figure 13.11

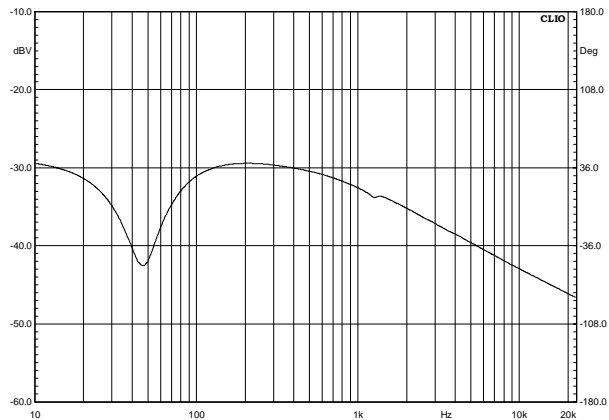
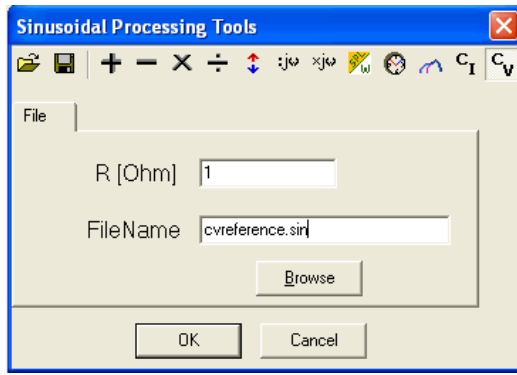


Figure 13.14

What we do from now on is just post processing. Leaving the last measurement in memory, open the Processing Tools Dialog from within Sinusoidal (MLS has the same), select the CV icon and input the data you should know.

The Ohm value is that of the Sensing Resistor while in the edit box you see the name of our previous file, cvreference.sin, including its own path which could be different in your case.



Pressing OK we get Fig. 13.15 which is our final result. Note that the Y Units have been changed to Ohm. This result is only in memory and should be saved now for further use.

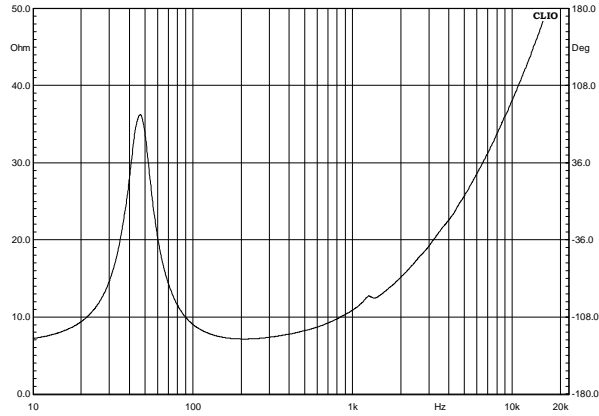


Figure 13.15

13.5.2 CONSTANT CURRENT

We will go quicker now as it's very similar to what we have just seen. Connections for creating the reference are the same, please refer to Fig. 13.11. Again everything should be left unchanged between creating the reference and the device files. The big difference from before is the output level. Here we choose a 1kOhm resistor. This will attenuate a lot of the signal at the loudspeaker terminals. Fig.13.16 shows the reference measurement.

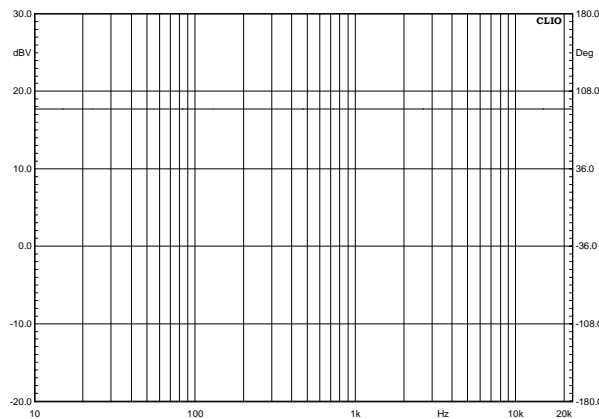


Figure 13.16

We have a straight line again; notice the level has become 17dBV now. We change connections, in accordance with Fig.13.17, and nothing else.

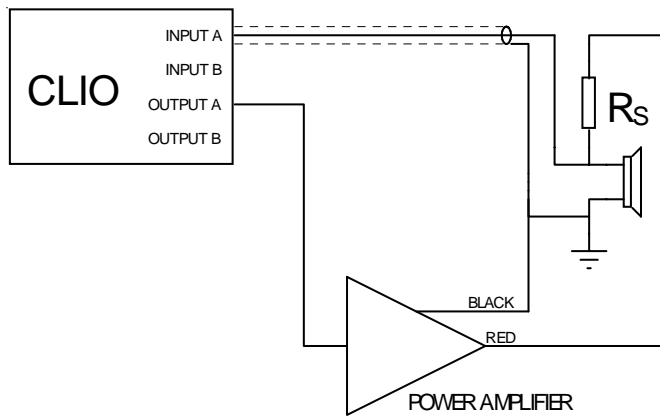


Figure 13.17

The figure shows us we are going to measure the voltage across the device. Therefore the next graph, Fig.13.18, will give us detailed information regarding the measuring level.

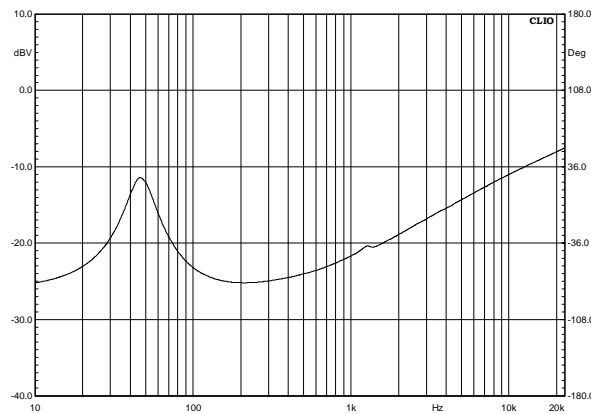
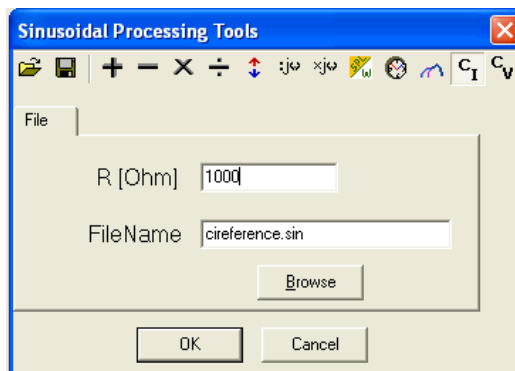


Figure 13.18

The level is low enough not to worry us and we proceed with our post process as before. Instead of the CV button CI should be selected.



Finally Fig.13.19 shows the process result.

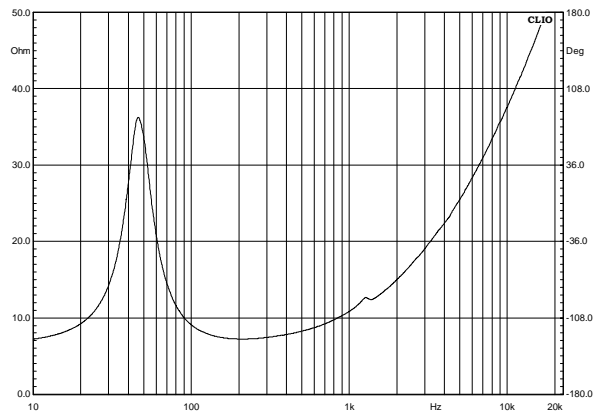


Figure 13.19

13.6 IMPEDANCE: SINUSOIDAL OR MLS

Up to now we have almost always used Sinusoidal to perform Impedance Measurements. When MLS has been used, it was to point out problems. We also stated Sinusoidal is the preferred choice. The inexperienced user might ask why the MLS Menu has impedance measuring capability at all. In fact MLS yields accurate Impedance Measurements. It is, however, less likely to forgive errors and/or measuring set-up problems of any kind. Users, however, should always take the maximum effort to avoid these situations anyway. Furthermore MLS has several advantages over Sinusoidal. The most evident is execution time which is significantly better, even using big sizes, which, by the way, is always advisable. It can measure down to 1Hz while Sinusoidal stops at 10Hz. Its high sensitivity to even weak non-linearity can be used to reveal even small rub & buzz problems, directly from the impedance measure. We advise you to use Sinusoidal measurement techniques initially until you become more experienced with CLIO. After which everyone will be able to form an opinion based on personal experience.

13.7 THIELE & SMALL PARAMETERS


13.7.1 INTRODUCTION

CLIO handles Thiele and Small Parameters, hereafter referred to as T&S, as a post process of impedance measurements. Three options are available for source data, selected by the Data Origin Drop Down Control: Sinusoidal Impedance Data, MLS Impedance Data, File Data, the last created with either of the previous. There are no conceptual differences between File and the first two options, beside where the data resides. Choosing Sinusoidal or MLS, the user should have one of these measurements in memory while the File Data option will prompt for file selection. Impedance measurements are therefore the central topic and the previous paragraphs are an essential background. To get the full set of T&S, two impedance curves are needed. The first is the loudspeaker's free air impedance, the second, the impedance obtained either with Delta Mass or Delta Compliance method. The first consists in adding a suitable Known Mass to the Loudspeaker cone, the latter in loading the cone with a box of Known Volume.

13.7.2 T&S PARAMETERS CONTROL PANEL

Manufacturer:						
Model:						
Date:						
Fs	0.0000 Hz	VAS	0.0000 L	RE	0.0000 Ω	
QMS	0.0000	QES	0.0000	QTS	0.0000	
B-l	0.0000 T·m	dB SPL	0.0000	Sp	0.0000 m ²	
CMS	0.0000 mm/N	MMS	0.0000 g	RMS	0.0000 Ω M	
CAS	0.0000 m ⁵ /N	MAS	0.0000 kg/m ⁴	RAS	0.0000 Ω A	
CMES	0.0000 μ F	LCES	0.0000 mH	RES	0.0000 Ω	
RAT	0.0000 Ω A	RMT	0.0000 Ω M	MMD	0.0000 g	
ZMIN	0.0000 Ω	ZMAX	0.0000 Ω	ZAVG	0.0000 Ω	
70	0.0000 %	L1kHz	0.0000 mH	L10kHz	0.0000 mH	

The User Interface is quite simple with three Buttons, one Drop Down and one Check Box.

 Starts a T&S Parameters procedure. See 13.7.3 for details.

 Delta Mass T&S Parameters calculation. See 13.7.3 for details.

 Delta Compliance T&S Parameters calculation. See 13.7.3 for details.

The Drop Down allows selecting the data origin as described in the introduction. The LSE Check Box, when checked, enables a Least Square Error routine while calculating T&S Parameters; more on this later. Besides information regarding the device tested, the Control Panel displays 27 parameters. Here is what they are.

13.7.3 GLOSSARY OF SYMBOLS

F_S	Resonant frequency of driver including air load
V_{AS}	Volume of air having the same acoustic compliance as driver suspension
R_E	DC electrical resistance of voice coil
Q_{MS}	Q of driver at F_s considering mechanical losses only
Q_{ES}	Q of driver at F_s considering electrical resistance only
Q_{TS}	Q of driver at F_s considering all driver losses
$B \cdot l$	Motor strength, product of B times l
dB_{SPL}	Acoustic pressure produced by the driver at 1m when driven by 2.83 V
S_D	Effective surface area of the driver cone
C_{MS}	Mechanical compliance of driver suspension
M_{MS}	Mechanical mass of driver cone assembly including air load
R_{MS}	Mechanical resistance of driver suspension losses
C_{AS}	Acoustic compliance of driver suspension
M_{AS}	Acoustic mass of driver cone assembly including reactive air load
R_{AS}	Acoustic resistance of driver suspension losses
C_{MES}	Electrical capacitance representing the driver total moving mass
L_{CES}	Electrical inductance representing the driver mechanical compliance
R_{ES}	Electrical resistance representing the driver mechanical losses
R_{AT}	Total acoustic resistance of driver
R_{MT}	Total mechanical resistance of driver (suspension losses + electrical reflected)
M_{MD}	Mechanical mass of driver cone assembly excluding air load
Z_{MIN}	Minimum impedance in the frequency range above F_s
Z_{MAX}	Impedance at F_s
Z_{AVG}	Average of impedance modulus over the measured frequency limits
η_0	Efficiency

$L_{1\text{kHz}}$

Inductance at 1kHz

 $L_{10\text{kHz}}$

Inductance at 10kHz

13.7.3 T&S STEP BY STEP

Getting T&S requires two impedance measurements. As we will use both methods we need three, the first relative to the driver in free air, the second to the driver with a known mass (Delta Mass) added to the cone, the third to the driver loaded with a known volume (Delta Compliance). Fig.13.20 shows the results of the three measurements, overlaid in one single graphic.

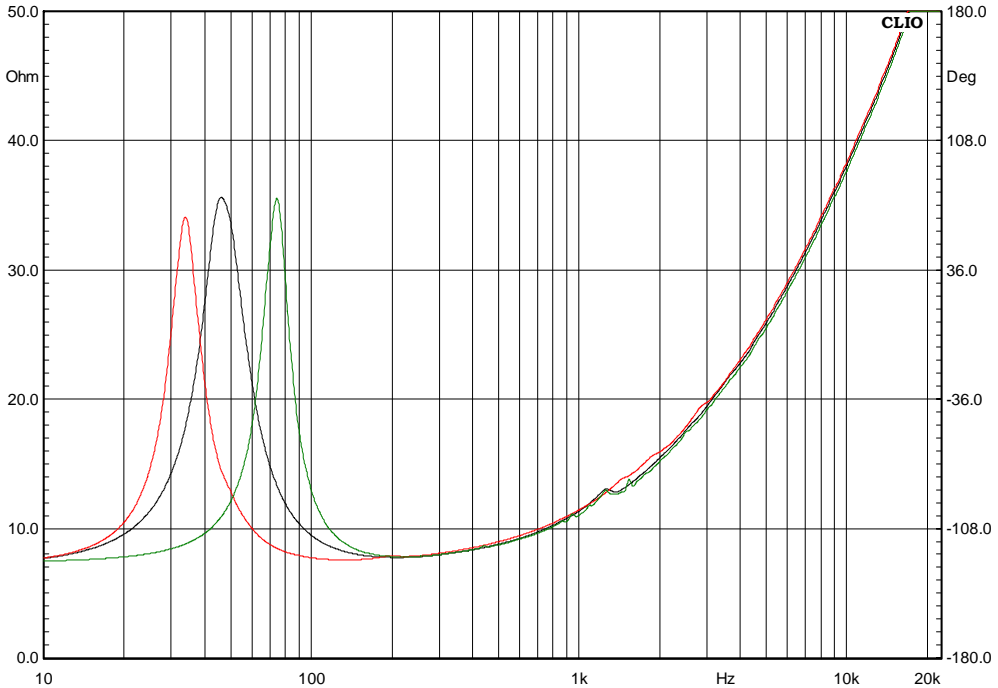
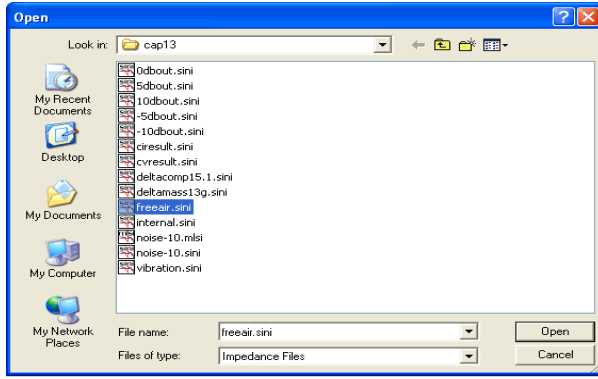


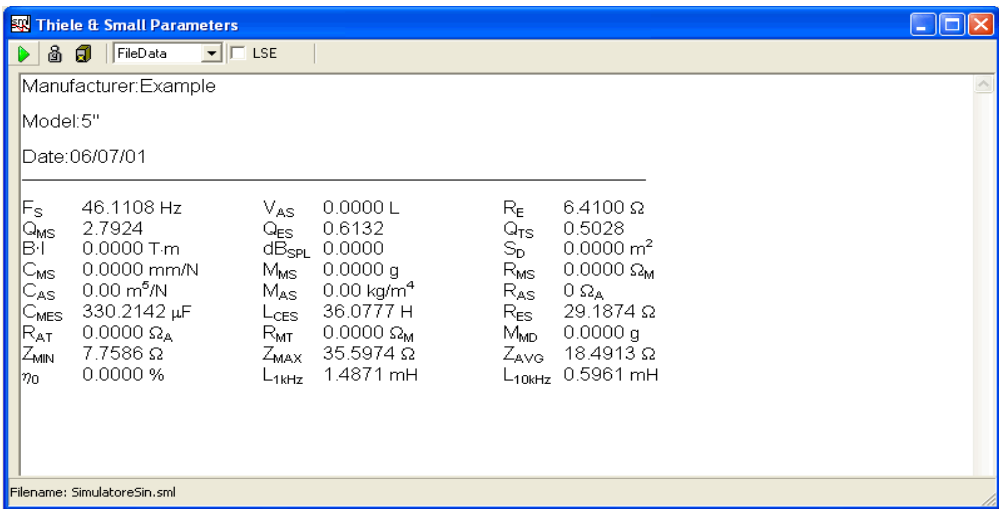
Figure 13.20

The black curve refers to free air, the red to delta mass, the green to delta compliance. As you can see adding a mass results in lowering F_s while loading the cone with a closed volume will increase F_s . Always check this is the case to avoid errors in the post processing routine. As deriving T&S parameters can be performed at any subsequent time after the impedance measurements has been taken, we suggest you save them with meaningful names as well as using the Notes Dialog to store the measuring conditions as mass weight and/or volume. The last step before pressing Go in the T&S dialog is to measure both the voice coil DC resistance and the effective cone diameter in millimeters. In this example they are 6.41 Ohm and 133mm. Finally we select File Data as the data origin and pressing Go we get the following prompt Dialog

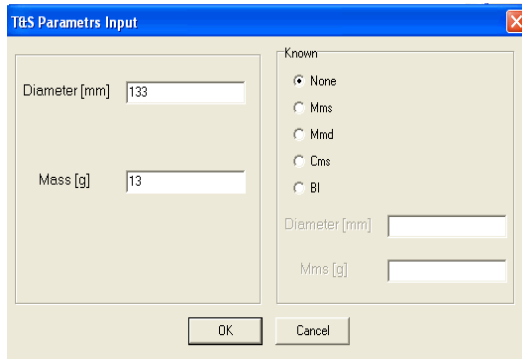
After the correct values have been typed in and clicking OK we will be prompted for the file name. The file required here is the free air impedance measurement.



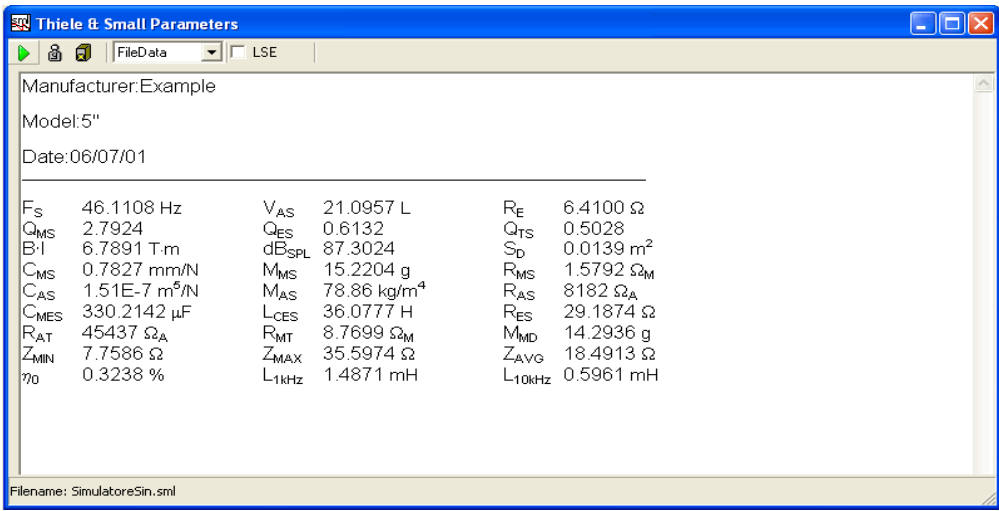
Opening the file we get this partially filled T&S parameters screen.



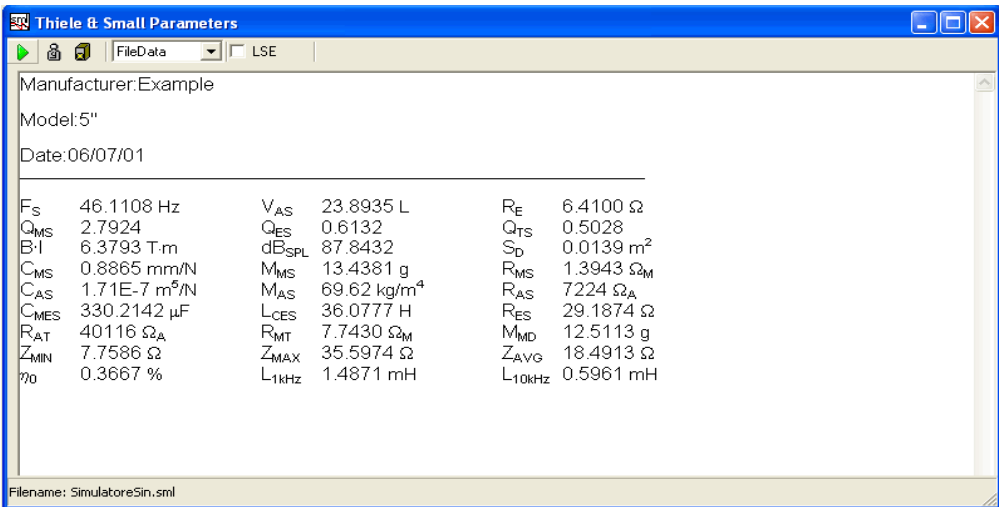
Now we can save this result for later use or proceed immediately for the missing parameters. Notice that the two Buttons for Delta Mass and Delta Compliance that were disabled before are now enabled. We Click on the Delta Mass Button and type in the required values



and, finally, after we have choose the impedance file obtained with the added mass, we get our completely filled T&S parameters screen



We can now save our complete results and proceed with the Delta Compliance. The free air derived data is already in memory and we can finally deal with the last part of the procedure, which is nearly the same as before. We will be prompted for volume instead of weight. Obviously the file we have to choose is relative to the driver loaded with a known volume (15.1 liters in this case). Here we show the results for the Delta Compliance method. The two sets of data do agree pretty well.



13.7.4 USING LSE (LEAST SQUARE ERROR)

With this option checked, T&S parameters are calculated in a more sophisticated way. Basically the parameters obtained in the standard way are used to derive the starting values for the equivalent electric circuit model. These values are then changed slightly around the initial value until the best fit between the calculated and measured impedance curve is found in a large frequency range around resonance. This procedure works fine and gives an accuracy advantage if the driver impedance fits the Thiele and Small model pretty well. Unfortunately this is not always the case. Should the user encounter such cases (if the parameters obtained with and without LSE differ substantially) the user must be aware that the entire concept of T&S parameters has lost its usefulness. This often happens with tweeters or woofers whose impedance has been measured at a high level with defective devices.

14 LINEARITY & DISTORTION

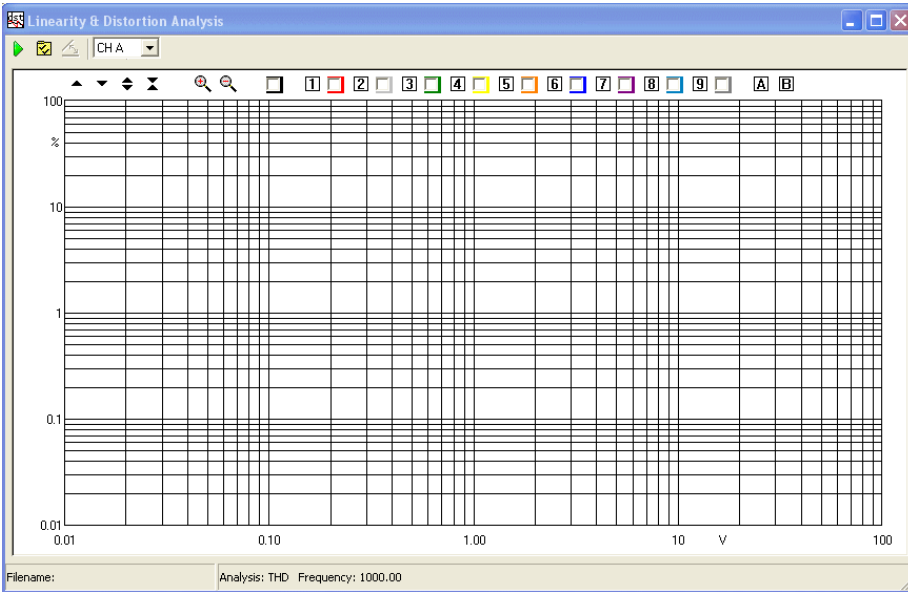
14.1 INTRODUCTION

Linearity and Distortion analysis are grouped together though they are, apparently, opposite terms.

From the analyser point of view however, they are similar as either the fundamental or the harmonics (intermodulation) amplitude is evaluated while sweeping D.U.T. input level.


Defining applications for these analysis would bring to an endless list, limited only by user fantasy; however the entire menu is oriented to perform measurements on electronic devices as power amplifiers or preamplifiers. The X axis units can be selected between Volts and Watts. So please don't put a microphone in front of a loudspeaker expecting useful results except, maybe, destroying the unit.

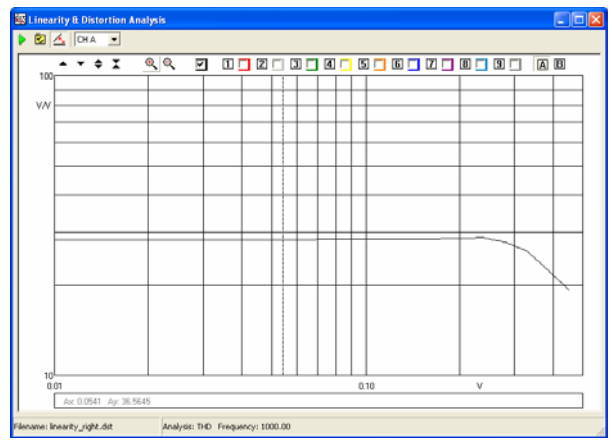
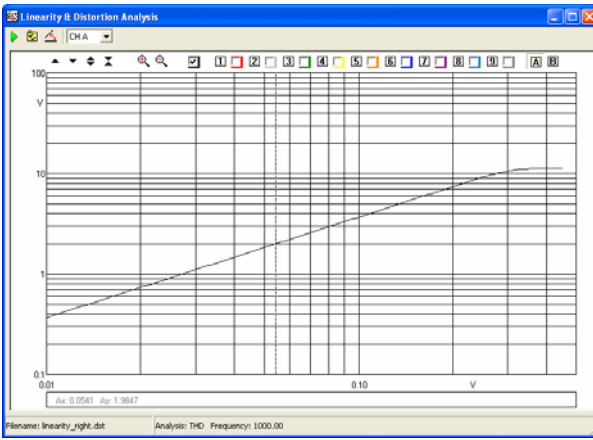
14.2 LINEARITY & DISTORTION CONTROL PANEL



 Starts a Linearity and Distortion measurement.

 Enters the Linearity and Distortion settings dialog box.

 Compute Linearity, and is enabled only if Linearity analysis is selected (in the settings dialog, see below). Basically the process consists in dividing the measured output by the supplied input. Doing this greatly simplifies realising both DUT gain and deviation from linearity. The following example should clarify things further.



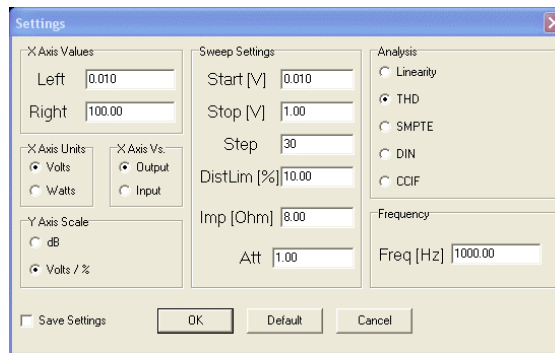
The graphs refers to a linearity measurement of a Push Pull tube amp. After processing, the Y scale can be expanded, still including the whole span, greatly enhancing detail inspection.

14.2.1 TOOLBAR DROP DOWN LIST

Input channel

Selects the input channel configuration

14.2.2 LINEARITY&DISTORTION SETTINGS DIALOG



X Axis Values

Allows setting the X axis extreme left and right values. Has immediate effect, once OK is pressed, and has only graphical implication; that is it does not affect the actual or next measure span.

X Axis Unit

Can be either Volts or Watts. Has immediate effect and the curve is recalculated accordingly. Changing the impedance in the sweep settings does not affect results as the impedance set at measuring time is taken for calculation. When Vs. input is selected in the **X Axis Vs.**, Volts is forced and the choice disabled.

X Axis Vs.

Selects if the X axis represents DUT output or input values. Input Values can only be expressed in Volts.

Y Axis Scale

Selects how the Y axis is displayed. When anything but **Linearity** is selected in the **Analysis** radio button panel, selecting **Volts/%** will display distortion in percent in

a bi-logarithmic graph. Selecting dB will plot distortion in dB below fundamental/s. When **Linearity** is selected dBV or Volts will be used as Y Unit. If the compute linearity button is pressed dB or V/V are used.

Sweep Settings

These are all settings affecting the next measure to be performed. Must be therefore handled with care.

Start and Stop

set the voltage sweep range supplied to the DUT input. Start should be lower in value than Stop. While these values can be chosen in an iterative way, having a rough idea of the DUT gain is a good practice. Notice however that keeping the DistLim parameter to or lower than 10% would prevent hard overload of the DUT. Sweep range stops anyway when the maximum allowed distortion is reached, whatever **Stop** value is chosen. **Stop** value cannot be greater than 3V, being this the CLIO's limit.

Step

set sweep resolution in logarithmic equal step.

DistLim

set, in percentage, the maximum allowed distortion before the sweep stop anyway.

Imp,

in Ohm, set the impedance used by the system to calculate power. Should obviously be set to the real impedance that loads the DUT. Changing this value after the measurement has no effect on an already done measure; the value should be correct **before** the measure is taken.

Att

set the value of an eventually used passive attenuator placed on CLIO's input. CLIO's input accept up to 100VRMS, that is 1250W/80Ohm. Should you need more, use a resistors divider on the input and set the **Att** value accordingly. Advised value are 90-10 Ohm to divide by 10.

Analysis

Through this radio button control the analysis type is selected.

Linearity

measure the output Voltage Vs input Voltage. Output level is measured through FFT looking only at the amplitude of the generated tone. That is harmonics noise or other is not considered in the output level.

THD

measures Total Harmonic Distortion. Again distortion level is calculated via FFT and therefore noise is not taken in account. These, in some limited cases, at lower level, yields to slightly different results than those obtained via traditional THD+noise measurements. This approach is, however, more accurate. For setting the measurement frequency please see below.

SMPTE

measures Intermodulation distortion using SMPTE standard. Two tones are generated in a 4: 1 ratio at 60Hz and 7000Hz. Intermodulation components up to the 5th order are considered for distortion.

DIN

measures Intermodulation distortion using DIN standard. Two tones are generated in a 4: 1 ratio at 250Hz and 8000Hz. Intermodulation components up to the 5th order are considered for distortion.

CCIF

measures Intermodulation distortion using two equal level near spaced (1kHz) in Frequency tones. Difference Intermodulation components up to the 2th order are considered for distortion. To keep results directly comparable with THD analysis both output Voltage or Power are single tone equivalent scaled. Considering a power amplifier clipping point, this usually due to the peak value of the signal rather than its RMS value. With two tone of equal level the RMS values is 3dB lower than the same peak to peak single tone.

Freq

Has no effect in SMPTE and DIN analyses which use fixed frequencies. Set the measurement frequency for Linearity and THD. Set the center Frequency for CCIF; for example 15500Hz means two tone are generated, spaced by 1kHz, at 15000Hz and 16000Hz

15 ACOUSTICAL PARAMETERS

15.1 INTRODUCTION

With the Acoustical Parameters control panel it is possible to evaluate the acoustical behaviour of a room and carry out sophisticated post processing of a measured impulse response to calculate the acoustical parameters as defined by the **ISO 3382** standard. These quantities describe the behaviour of auditoria, concert halls and are applicable to any room intended for speech or music reproduction.

15.2 THE ACOUSTICAL PARAMETERS CONTROL PANEL

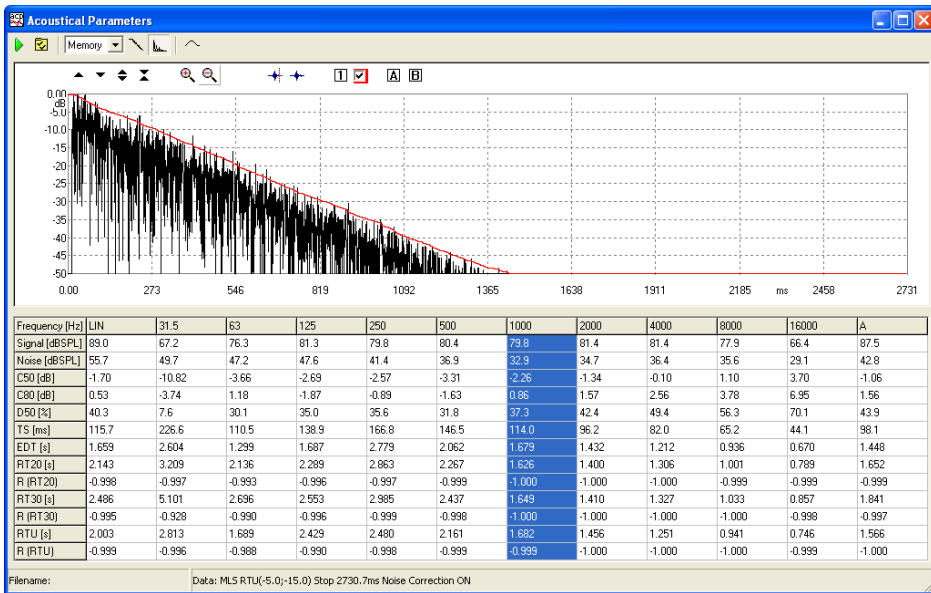




Fig. 15.1 The Acoustical Parameters control panel

In Fig. 9.1 you can see the Acoustical Parameters control panel; this figure shows an octave filtered impulse response (at 1kHz) presented both as reverberant decay and ETC; then all the calculated parameters are listed in tabular form.

The source of any acoustical parameters calculation is a measured **Impulse Response**; CLIO gives you this possibility by means of the MLS&LogChirp menu; please refer to chapter 10 where it is described how to measure the impulse response of a room using MLS or LogChirps.

For a detailed description of the graphical display (common also to other measurement control panels) and its capabilities please refer to Chapter 6. For a description of the available shortcuts please refer to section 5.5.2.


15.2.1 TOOLBAR BUTTONS AND DROP DOWN LISTS


-  Starts an Acoustical Parameters calculation. See below the data source for the calculation.
-  Enters the Acoustical Parameters Settings dialog box.


impulse response data source drop down


Selects the source of impulse response data among the following:

- **Memory**. The impulse response is already in memory and is reprocessed with current settings.
- **File**. The impulse response is loaded from disk.
- **MLS**. Current impulse response loaded in the MLS control panel is processed.

 Enters the **impulse display mode** and shows the Schroeder reverberant decay relative to the selected fraction of octave. The impulse response under processing is first octave filtered and then the Schroeder decay evaluated.

 Enters the impulse display mode and shows the ETC relative to the selected fraction of octave.

 Enters the **frequency display mode** and shows the selected acoustical parameter versus frequency behaviour.

 Selects the time instant after which the impulse response data are discarded. The parameters calculation start from this point backwards. It permits you to eliminate unwanted behaviours of the room under test and measurement artifacts.

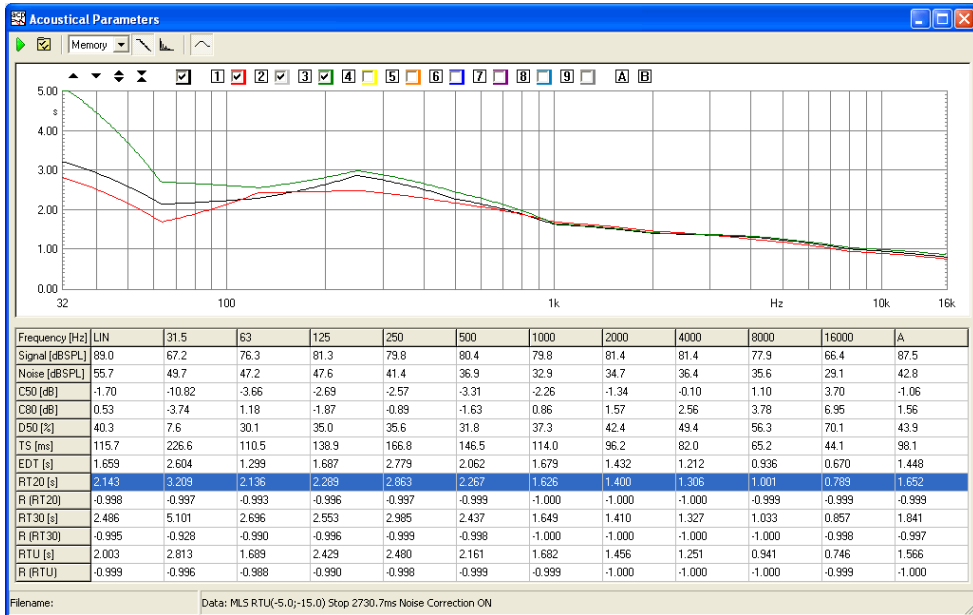
15.2.3 INTERACTION WITH THE A.P. CONTROL PANEL

It is possible to interact with the acoustical parameters control panel simply clicking on the parameters data table.

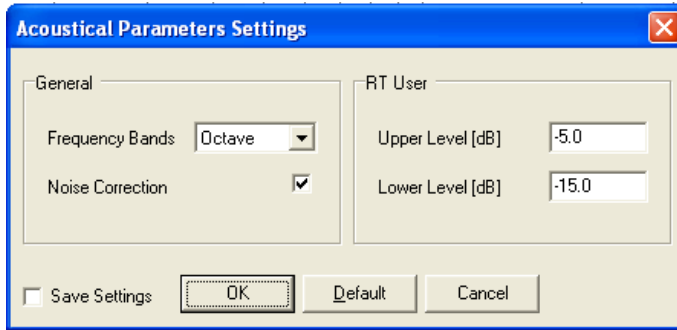
To enter the **impulse display mode** simply click on the table **first row** and select the desired octave band of interest; the selected column will change accordingly and the decay (or ETC) will also follow. The Fig.15.1 shows the selection of the 1kHz octave to which corresponds the ETC calculated.

The **leftmost column** gives wideband parameters (**Lin**) calculated over the whole available bandwidth. The **rightmost column** gives wideband parameters (**A**) calculated applying an A-Weighting filter.

To enter the **frequency display mode** simply click on the table **first column** and select the desired parameter whose behaviour versus frequency should be displayed; the selected row will change accordingly. The following figure shows the selection of the RT20 row and its behaviour vs. frequency (black curve); in comparison the overlays show RT30 (green curve) and RTUser (red curve). It is not possible to select the three rows of the correlation coefficients (see below) of the calculated RT60.

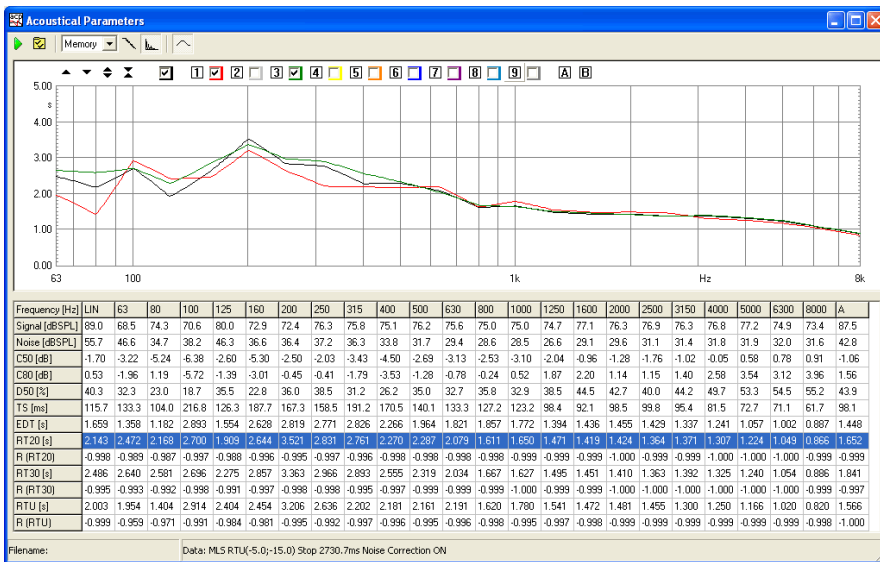


15.3 ACOUSTICAL PARAMETERS SETTINGS



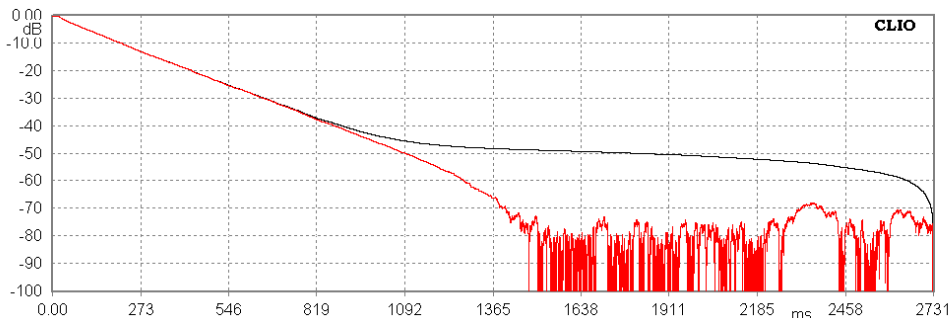
Frequency Bands

Selects either Octave or Third of Octave calculations. The following figure shows the same data analyzed before in octave bands now presented with 1/3 of octave processing.



Noise Correction

Applies noise correction to the tail of the impulse response as suggested by ISO 3382. The figure below shows the increase in the linear portion of the calculated decay which is obtainable.



RT User

It is possible to input the upper and lower level, in dB, used for RTUser calculations.

15.4 THE CALCULATED ACOUSTICAL PARAMETERS

The acoustical parameters are calculated from a measured **decay curve**. A decay curve is defined as the decay of sound pressure level as a function of time after the sound source has ceased. The decay curves are calculated from the measured impulse response after octave filtering has been applied; also wideband (linear or A-weighted) decay curves are available.

Historically the most important acoustical parameter is the **Reverberation Time** (T or RT) defined as the time, in seconds, that would be required for the sound pressure to decrease by 60dB after the sound source has ceased; this is why the most used indication you find in literature for the reverberation time is **RT60**. As it is normally practically difficult to obtain a sufficient dynamic range to measure the reverberation time **directly**, the norm provides for its evaluation based on a smaller decay of 30dB; in this case the reverberation time, indicated as RT30, should be the time evaluated considering a linear decay given by the least-square regression of the measured curve from -5dB to -35dB. Also provided is the possibility of evaluating RT20 and RTUser (based on user defined limits).

Sound level parameters.

Signal [dBSPL]. Measured signal level in dBSPL in the band of interest.

Noise [dBSPL]. Measured background noise level in dBSPL in the band of interest.

Balance between early and late arriving energy.

C50 [dB]. 50ms early-to-late arriving sound energy ratio (i.e. ratio between the energy arrived in the first 50 milliseconds to the energy arrived after). C50 is usually evaluated when results relate to speech reproduction.

C80 [dB]. Usually named "Clarity". 80ms early-to-late arriving sound energy ratio. C80 is usually evaluated when results relate to music reproduction.

D50 [%]. Usually named "Definition". Directly relates to C50 with the following equation:

$$C_{50} = 10 \log\left(\frac{D_{50}}{1 - D_{50}}\right) dB$$

TS [ms]. Time of centre gravity of the squared impulse response. It is another measure of acoustic clarity; the higher Ts the poorer is clarity.

Decay time measurements.

EDT [s]. Early Decay Time i.e. time required to sound to decrease of 10dB from the initial maximum level. EDT is directly related to the perceived reverberance while reverberation time relates to the physical properties of the room.

RT20 [s]. Reverberation time evaluated from a 20 dB dynamic range (-5dB,-25dB). See also below the **correlation coefficient R** associated with RT20.

RT30 [s]. Reverberation time evaluated from a 30 dB dynamic range (-5dB,-35dB). See also below the **correlation coefficient R** associated with RT30.

RTU [s]. Reverberation time evaluated from a user defined dynamic range; refer to 15.3 acoustical parameters settings. See also below the **correlation coefficient R** associated with RTUser.

R(RT). Each reverberation time estimation (RT20, RT30 and RTU) has associated a negative number which is the correlation coefficient R showing how closely the corresponding decay curve fits a straight line. A value of -1 gives a perfect linear fit. **When the correlation coefficient is smaller than -0.95 the RT value should be viewed with suspect as the decay curve may not be sufficiently linear; direct inspection of the decay curve with markers should be carried out.**

15.5 NOTES ABOUT ACOUSTICAL PARAMETERS MEASUREMENT

This paragraph gives some guidelines that should be followed while executing the measurement of the impulse response of rooms; what said here should be considered together the general procedure that is described in chapter 10 for executing MLS measurements.

The sound source shall be as omni-directional as possible. Maximum acceptable deviation from omni-directionality should not be higher than $\pm 1\text{dB}$ up to 500Hz, $\pm 3\text{dB}$ at 1kHz, $\pm 5\text{dB}$ at 2kHz, $\pm 6\text{dB}$ at 4kHz when excited with octave bands noise and measured in a free field.

Regarding **measurement positions** it is important to execute an adequate number of measurements with different source and receiver positions to characterize the entire room. For large auditoria a number of measurements from 6 to 10 in dependence of the number of seats (from 500 to 2000) should be carried out.

The microphone should be placed at a height of 1.2m above the floor at audience seat locations to be representative of listener's ear height.

16 Leq LEVEL ANALYSIS

16.1 INTRODUCTION

With the Leq Analysis control panel it is possible to execute **real-time capture and level measurement** of any kind of signal present at CLIO's input. The behaviour of the instrument closely resemble that of a graphical level recorder plus direct-to-disk data capture.

When analyzing an acoustical event this control panel gives you complete informations about the equivalent continuous sound level (Leq) and related quantities according to IEC 61672 standard; if used together the FFT frequency analysis you get a complete **integrating sound level meter**.

16.2 THE Leq CONTROL PANEL

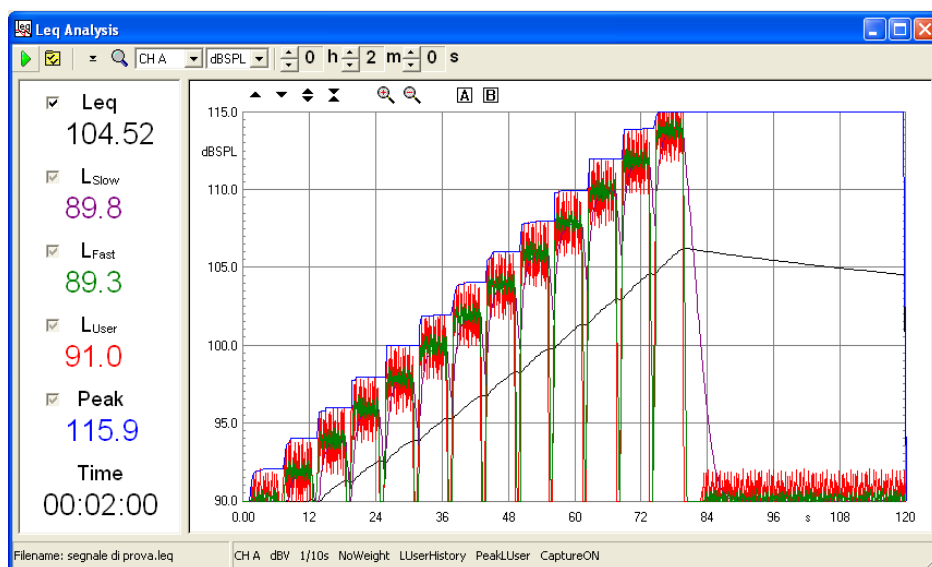






Fig. 16.1 The Leq control panel

In Fig. 16.1 you can see the Leq Analysis control panel; this figure shows a low frequency signal, increased in 2dB steps each maintained for 6 seconds, used for subwoofers power handling capability. To be noted the **equivalent level Leq** (black curve), the **time history** (red curve), the **peak level** (blue curve) and the levels with **slow and fast** integration (purple and green curves).

For a description of the available shortcuts please refer to section 4.5.2.

16.2.1 TOOLBAR BUTTONS AND DROP DOWN LISTS

-  Starts a Leq acquisition and analysis. If data capture is active the event is automatically registered on the hard disk.
-  Enters the Leq Analysis Settings dialog box.
-  When pressed, resets peak value. Does not affect any other calculation.
-  Activates real time data display; useful for high resolution time measurements (1/100s and 1/1000s).

channel display

Selects the input channel to display among the following:

- Channel A only
- Channel B only
- Channel BAL (two channels used in balanced configuration)

Y scale units

Selects the measurement units among the following:

- dBV
- dBu
- dBRel (with respect to the global reference level; see chapter 8)
- dB SPL (for acoustical measurements)

Stop Hours, Minutes and Seconds

Inputs the measurement stop time. It is possible to select up to 23h59m59s measurement time.

16.2.3 INTERACTION WITH THE Leq CONTROL PANEL

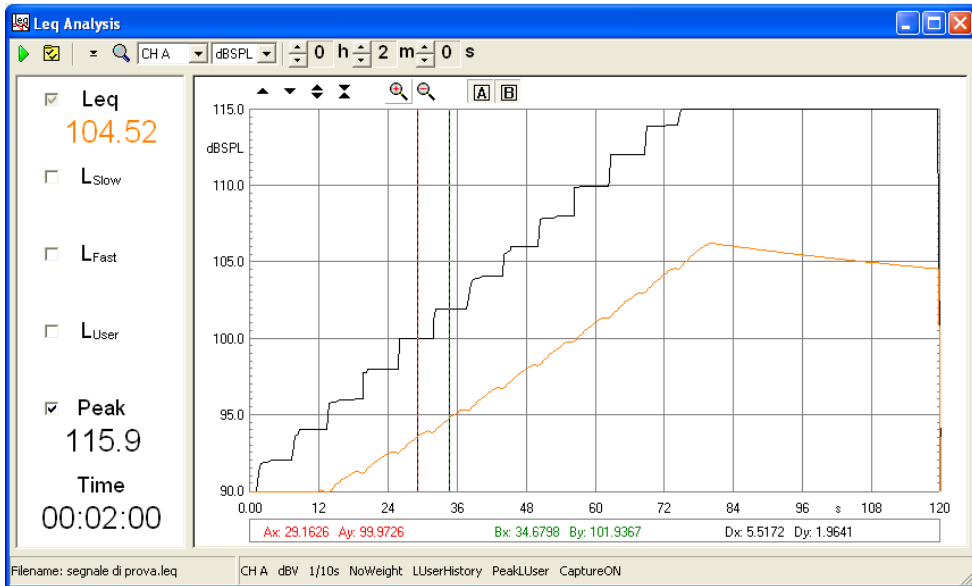
It is possible to interact with the Leq control panel clicking on the left data display where you can find five **three state checkboxes**.

Each checkbox refers to one calculation and data curve. Its state can be: **Deselected**. The data value and corresponding curve are **NOT** displayed.

Selected. The data value and corresponding curve are displayed with their color.

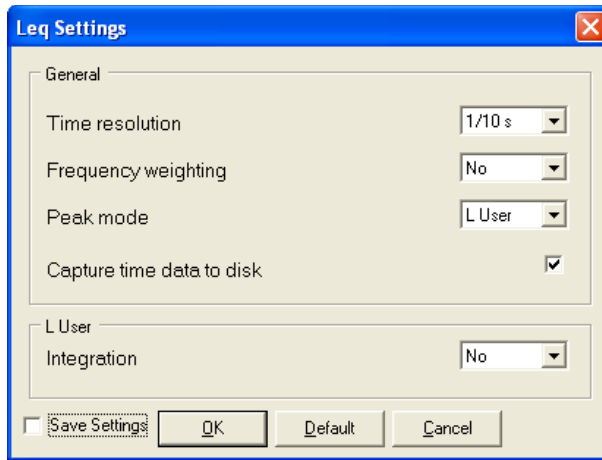
Active. The data value and corresponding curve are displayed in black and curve values are inspectable with the A and B markers.

In the following figure you may see the same measurement presented in figure 16.1; we have done the following; the fast, slow and time history levels have been deselected, i.e. hidden, the peak level is now active (black curve) and inspected with the two markers while the Leq is simply visible (orange curve and value).



Below the five calculated data value you can see the actual time display which changes during measurement or, at the end, states the total duration of it.

16.3 Leq SETTINGS



Time resolution

Selects the time resolution of the measurement. It is possible to choose a value among 1s, 1/2s, 1/4s, 1/10s, 1/100s and 1/1000s. Normally choose the least resolution possible as this choice directly reflects on the measured data size (**.leq** binary files). This setting is not influencing the sampling frequency that remains 48000Hz.

Frequency weighting

Selects the frequency weighting applied; you can choose either No Weight or A-Weighting.

Peak mode

Selects how the peak is measured. You may select between the two:

- **Max**. The peak is the maximum value acquired given the particular time resolution and frequency weighting.
- **LUser**. The peak is the maximum value of the LUser measurement.

Capture time data to disk

If active, during the measurement the acquired time data is saved to the hard disk. It is then possible to create a standard wave file of the event measured for later post processing. Be extremely careful when activating this feature as it requires a huge amount of disk space: circa **6MB/min** or **0.35GB/hour**.

Maximum recordable time is 12 hours.

LUser integration

Selects the time integration of the user definable level measurement. You may choose among the following:

- **No**. No integration is applied; the result is that the classical time history is displayed.
- **Impulse**. Classical Impulse integration, 35ms time constant with 2.9dB/s decay rate.
- **35ms**. Modified impulse integration; only 35ms time constant.

17 WOW AND FLUTTER

17.1 INTRODUCTION

Within this menu Wow & Flutter measurements are possible, meeting both IEC and NAB standards. Basically, what is measured is the frequency modulation that follows instantaneous speed variations due to mechanical imperfections in analog recording or playback devices. Differently than in traditional Wow & Flutter analyser the whole measuring process is taken digitally without relying on analog FM discriminator, filter and detector with much higher accuracy, limited by the clock quartz only. Furthermore, aside traditional number data, a time graph is presented as well as a Frequency Domain Analysis of the demodulated signal. The latter feature greatly simplify locating the cause of problems, once rotating speed and mechanical circumference of eventually defective rotating parts are known. Carrier frequency can range form 1500Hz to 6000Hz. This is important if you record directly the test signal. Using existing test support, IEC specify a test frequency of 3150Hz, NAB of 3000Hz.

17.2 WOW & FLUTTER CONTROL PANEL

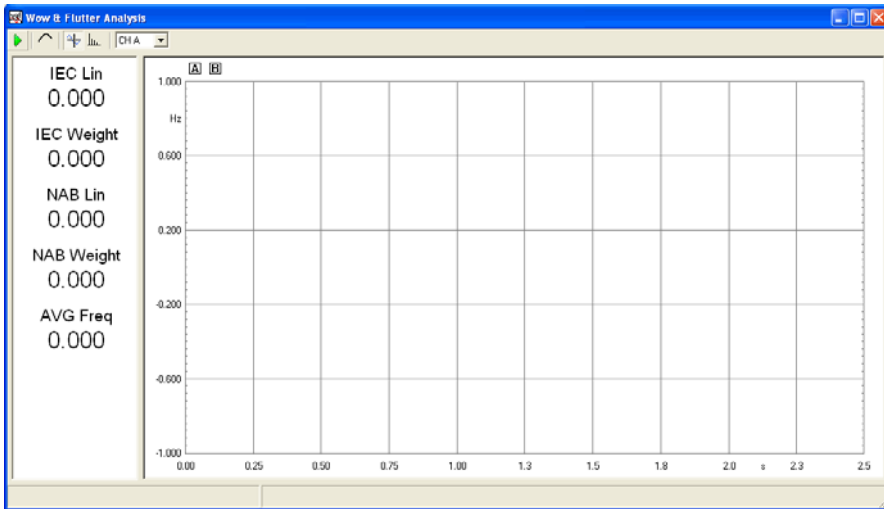



Figure 17.1

17.2.1 TOOLBAR BUTTON

 Starts a Wow & Flutter analysis.

 Enables weighting filter in the time domain windows. Frequency Domain remains unaffected. Works both when the analysis is running or as a post process.

 Switch to Time Domain.

 Switch to Frequency Domain.

17.2.2 TOOLBAR DROP DOWN LIST

Input channel

Selects the input channel configuration

17.3 FEATURES

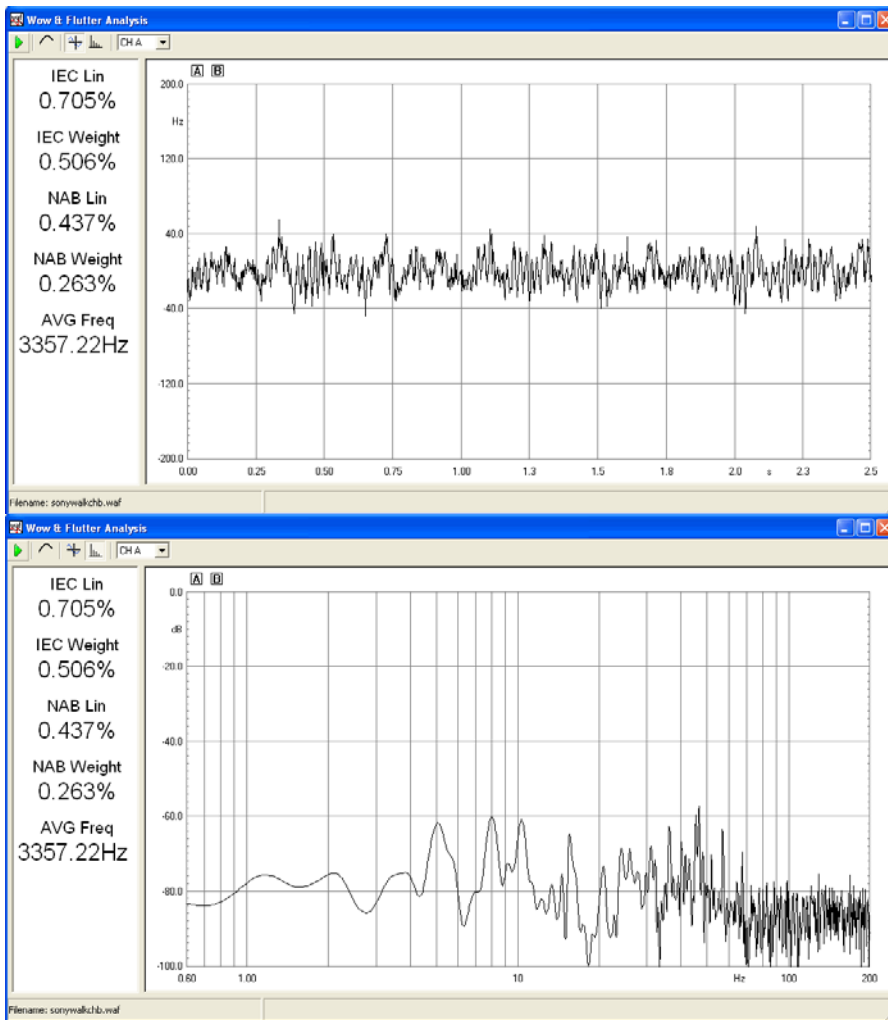


Figure 17.2

Aside a self explaining graphical part, on the left part several numeric data are present simultaneously. From top to bottom they are:

IEC LIN

expressed in percentage, express the WOW & FLUTTER value, unweighted, following IEC standard.

IEC WEIGHT

expressed in percentage, express the WOW & FLUTTER value, weighted, following IEC standard.

NAB LIN

expressed in percentage, express the WOW & FLUTTER value, unweighted, following NAB standard.

NAB WEIGHT

expressed in percentage, express the WOW & FLUTTER value, weighted, following NAB standard.

AVG Freq

expressed in Hertz is the frequency of the carrier tone. Is a direct indication of a static speed error.

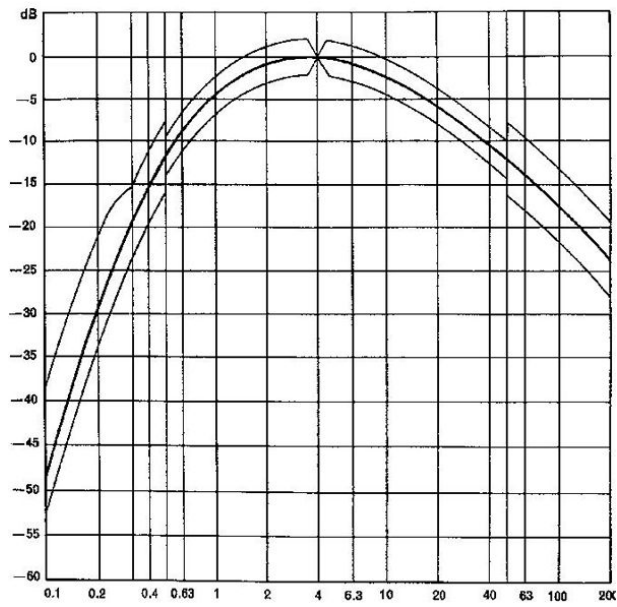


Figure 17.3

In the above figure the weighting filter response is displayed. This apply both to IEC and NAB standards. Aside carrier Frequency the main difference between them is the detector that evaluate the demodulated signal, which is peak detection in IEC and RMS in NAB; IEC Wow & Flutter values are usually greater.

18 WAVELET ANALYSIS

18.1 INTRODUCTION

The Wavelet Analysis tool allows to post-process impulse responses and to create color plots of the energy of the signal versus time and frequency. The tool is similar to the ETF analysis described in chapter 12, but since it is based on wavelet transform instead of Fourier Transform, does not suffer from the fixed time-frequency resolution.

The ETF analysis is based on Short Time Fourier Transform (STFT). The idea behind STFT is to show the temporal evolution of the signal by means of the division of the signal itself into short sections and then Fourier Transform every section. In this way the joint time-frequency evolution of the signal is highlighted. But at the same time the process lead to a fixed time and frequency resolution, due to the fact that time resolution is linked to section duration and frequency resolution is linked to FFT size.

The Wavelet Analysis tool implemented in CLIO uses a kernel of modified complex Morlet wavelets and can be interpreted as a constant Q analysis. Time resolution is high at high frequencies and frequency resolution is not too rough at low frequencies. This kind of analysis it is particularly suited for the inspection of wideband non stationary signals as the impulse responses of loudspeakers and rooms.

As a result of the Wavelet Analysis post-processing tool a matrix of coefficients is calculated. The magnitude squared of the coefficients is directly proportional to the energy of the signal in a domain located around a certain time and frequency. The magnitude squared of the Wavelet coefficients is depicted into a color plot called Scalogram:

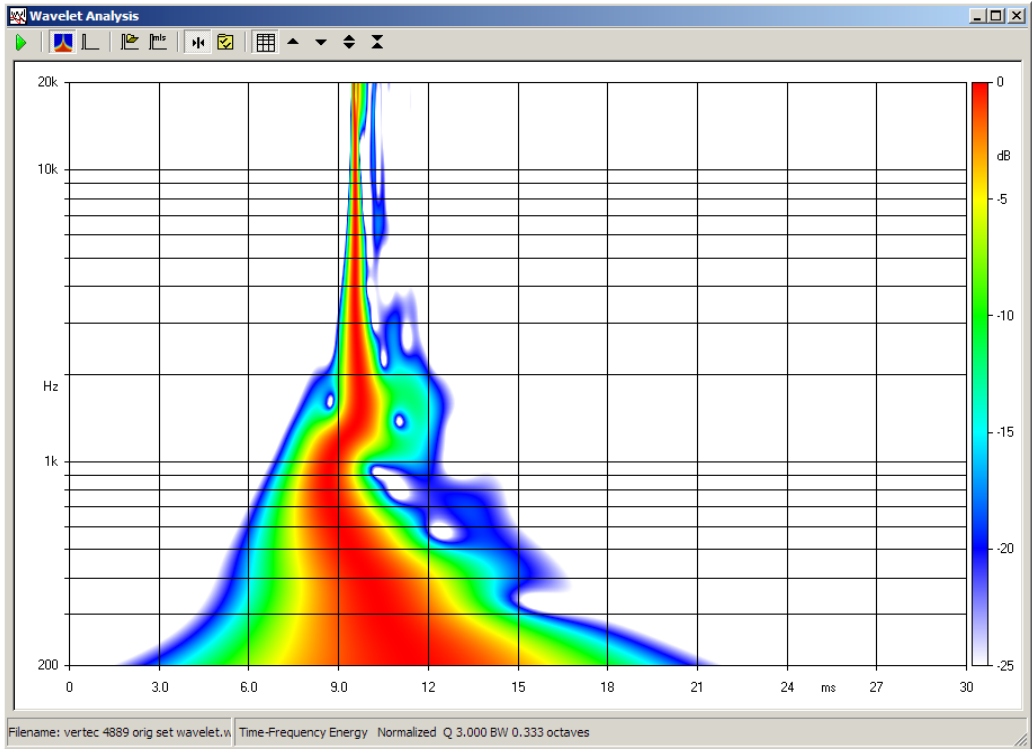



Figure 18.1 - Wavelet Analysis panel


18.2 WAVELET ANALYSIS CONTROL PANEL

Fig 18.1 show the Wavelet Analysis control panel, the behaviour of this menu is similar to the Waterfall menu as seen in chapter 18.

As already stated the source of data for Wavelet Analysis is an impulse response, please refer to chapter 10 (MLS&LogChirp) to have details on how to measure an impulse response.

18.2.1 COMMON TOOLBAR BUTTONS AND DROP DOWN LISTS

 Starts a Wavelet Analysis calculation.

 If pressed each frequency slice of the spectrogram will be referenced to the its energy time maximum; the plot can be interpreted as the energy decay of the system.

 Enters the settings dialog. See 18.3.

 Moves the plot up.

 Moves the plot down.


 Expands the plot changing its Z scale. The Z range is reduced.

 Compresses the plot changing its Z scale. The Z range is increased.

 When pressed the wavelet analysis (scalogram) plot is displayed.

 When pressed the grid is displayed.

 When pressed the impulse response loaded in memory is displayed

 Loads an impulse response from disk (from MLS binary files).

 Takes current MLS impulse response for wavelet calculation.

18.3 WAVELET ANALYSIS SETTINGS

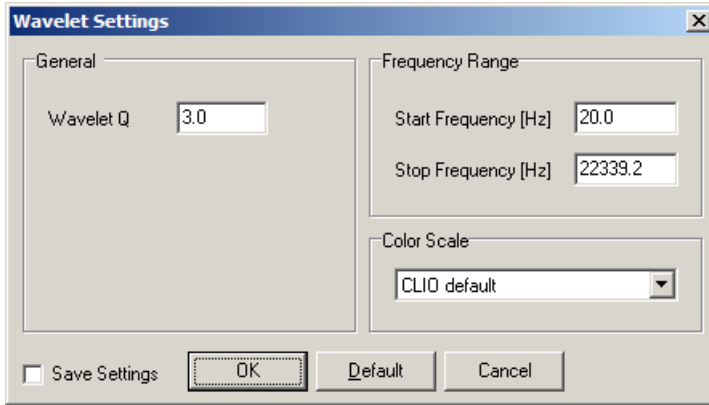


Figure 18.2 - Wavelet Settings Dialog

Start Frequency

Selects the start frequency for the analysis.

Stop Frequency

Selects the stop frequency for the analysis.

Wavelet Q

Selects the frequency resolution for the analysis, see also 18.4.1 (Q>3)

Color Scale

Selects the color gradient scale to be used:
CLIO Default - standard CLIO color map
Jet Colormap - red to blue color map

18.4 WAVELET ANALYSIS OPERATION

As already stated the data source for the Wavelet Analysis is a measured impulse response.

Once you have loaded an impulse response inside the Waterfall Analysis control panel you may easily inspect it, in the same way you also do with the MLS Impulse control panel (See chapter 10). The limits in time of the Wavelet Analysis plot will be the same of the impulse plot view. It is possible to window the impulse response (by means of a rectangular window) as in MLS&LogChirp control panel prior to the Wavelet Analysis computation.

Pressing the Go button run the Wavelet Analysis, the calculation time is dependant from the impulse response size, in older PCs and in case of very long impulse responses this can take up to 2 minutes. Computation time in a modern PC is limited to few seconds.

Once the Wavelet is calculated it is possible to zoom in/out into time without running again the Wavelet Analysis.

18.4.1 TRADING BANDWIDTH AND TIME RESOLUTION

As said before, changing the Wavelet Q parameter is it possible to trade time resolution with bandwidth resolution.

The product of temporal uncertainty and bandwidth uncertainty is fixed, the Q parameters lets adjust the frequency resolution that in turns influences time resolution.

In the following figures some examples of the same impulse response with different Q are reported.

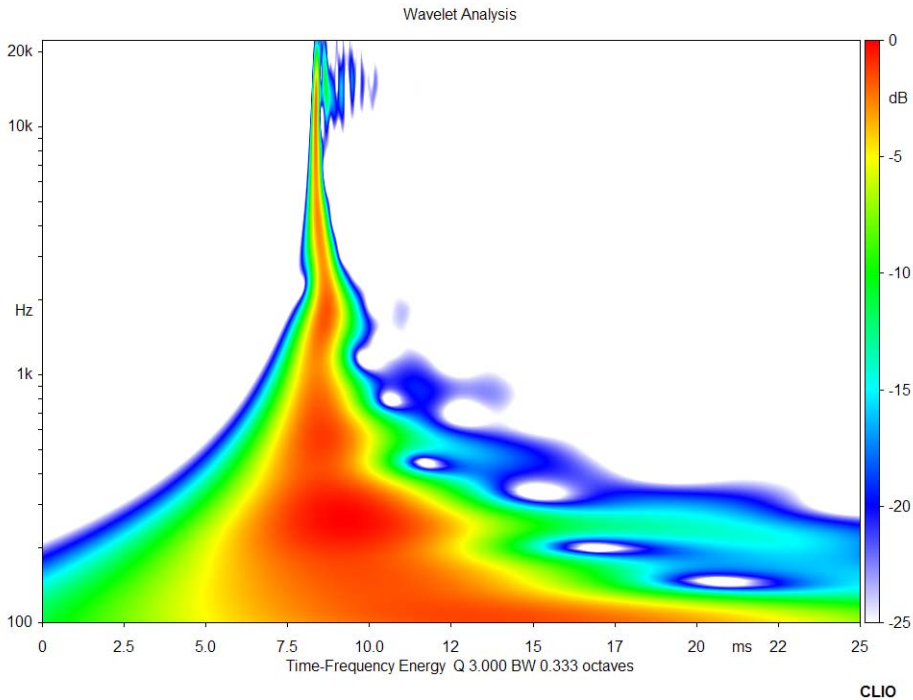


Figure 18.3 - Wavelet Analysis of loudspeaker impulse response $Q=3$

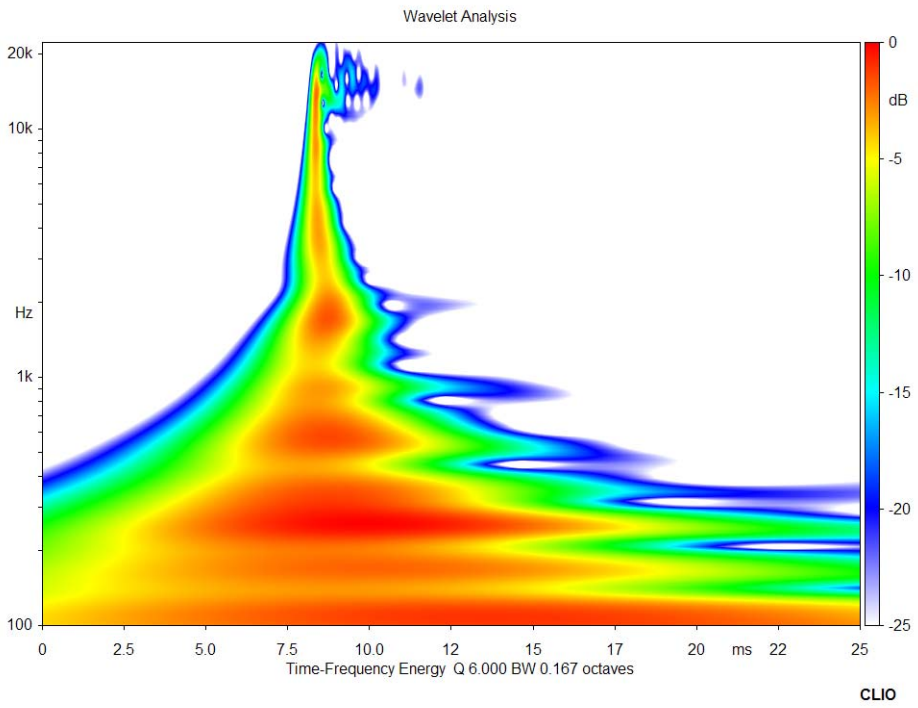


Figure 18.4 - Wavelet Analysis of loudspeaker impulse response $Q=6$

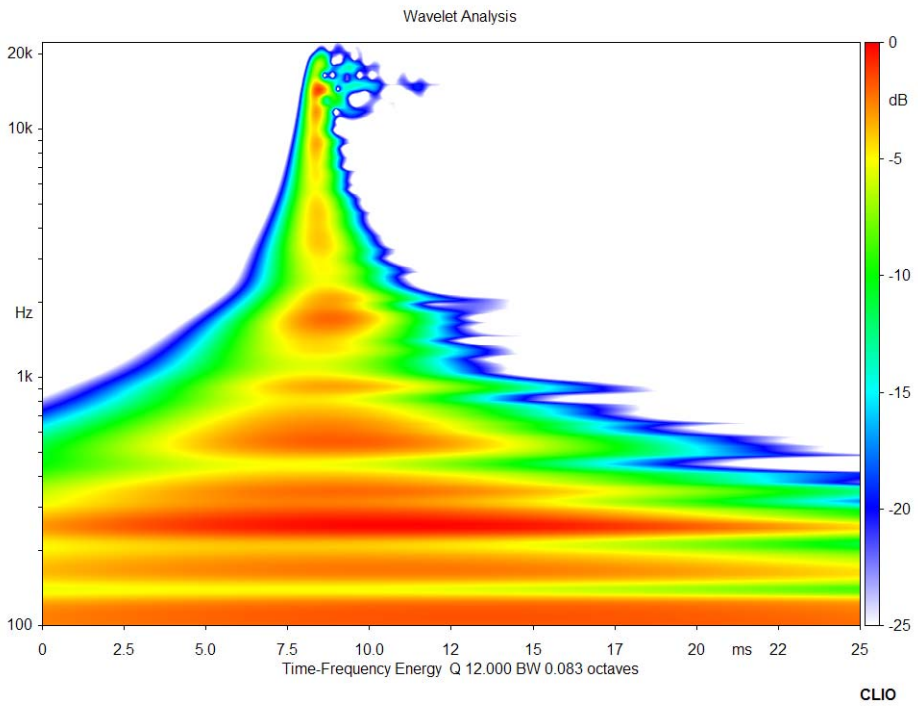


Figure 18.5 - Wavelet Analysis of loudspeaker impulse response $Q=12$

18.4.2 NORMALIZED SCALOGRAMS

The matrix of the coefficient calculated with the Wavelet Analysis is the Scalogram. The magnitude squared of every cell of the scalogram is proportional to the energy of the signal in a domain located around given time and frequency points.

Due to the uncertainty in time, the energy content it is smeared in time and somewhat difficult to interpret.

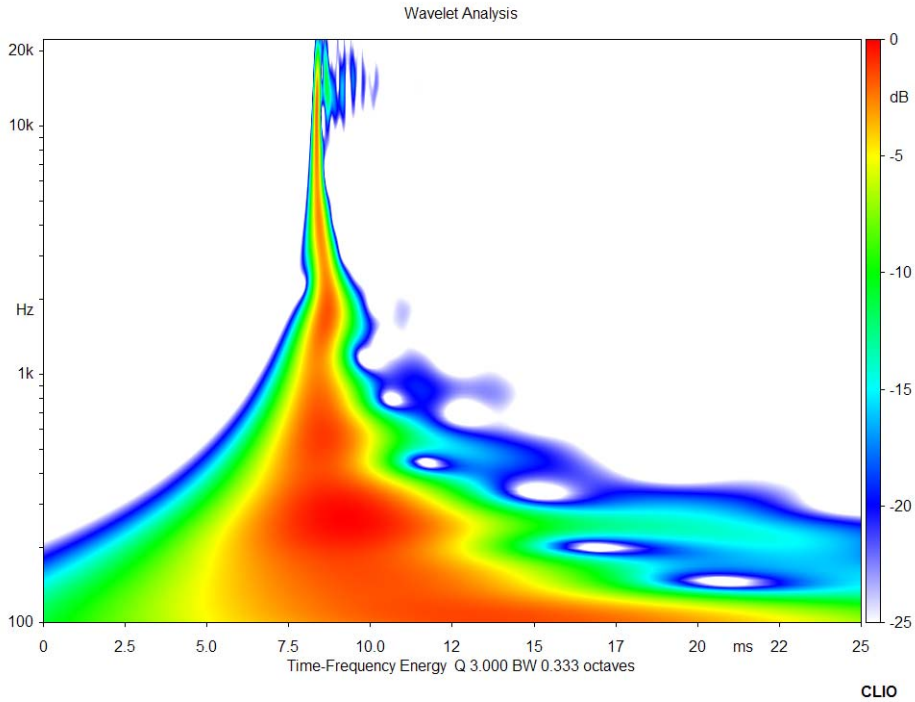


Figure 18.6 - Wavelet Analysis of loudspeaker impulse response - Not normalized

If we are interested to the time-frequency energy decay of the sistem, the normalized view is more clear. Since every frequency slice it is normalized to its energy time maximum, the map can be loosely interpreted as the time-frequency energy decay of the system. The red area is a clear view of the time response of the system versus frequency and can be taught as an extension of the excess phase group delay method shown on section 10.4.4.

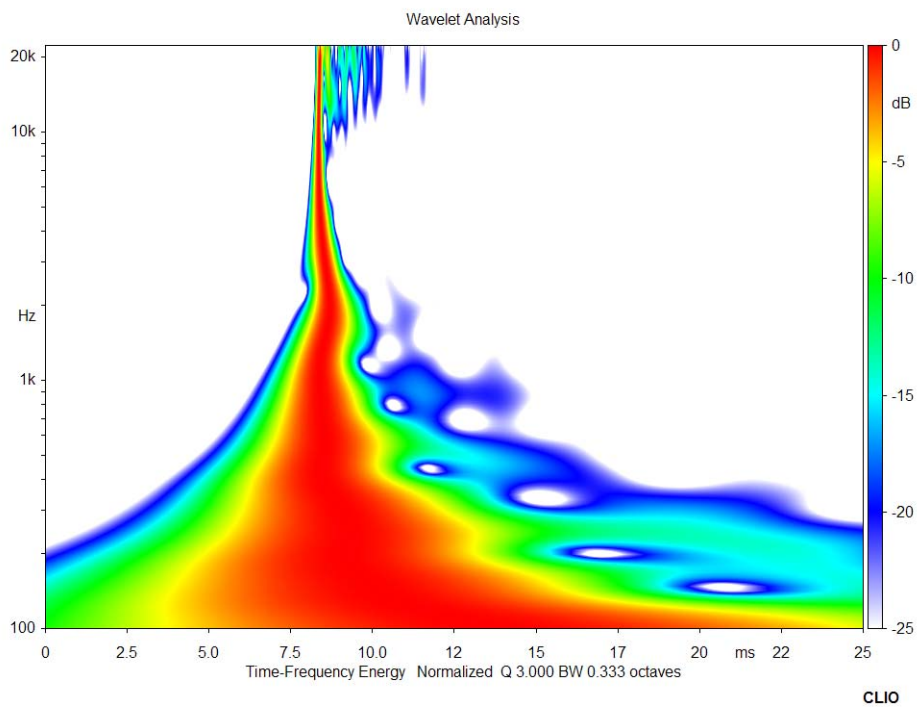


Figure 18.7 - Wavelet Analysis of loudspeaker impulse response - Normalized

BIBLIOGRAPHY

- [1] Joseph D'Appolito, "Testing Loudspeakers", Audio Amateur Press, 1998.
- [2] J.M. Berman and L.R. Fincham, "The Application of Digital Techniques to the Measurement of Loudspeakers", J. Audio Eng. Soc., Vol. 25, 1977 June.
- [3] L.R. Fincham, "Refinements in the Impulse Testing of Loudspeakers", J. Audio Eng. Soc., Vol. 33, 1985 March.
- [4] S.P. Lipshitz, T.C. Scott and J. Vanderkooy, "Increasing the Audio Measurement Capability of FFT Analyzers by Microcomputer Postprocessing", J. Audio Eng. Soc., Vol. 33, 1985 September.
- [5] D.D. Rife and J. Vanderkooy, "Transfer Function Measurement with Maximum-Length Sequences", J. Audio Eng. Soc., Vol. 37, 1989 June.
- [6] A. Duncan, "The Analytic Impulse", J. Audio Eng. Soc., Vol. 36, 1988 May.
- [7] J. Vanderkooy and S.P. Lipshitz, "Uses and Abuses of the Energy-Time Curve", J. Audio Eng. Soc., Vol. 38, 1990 November.
- [8] G. Ballou, "Handbook for Sound Engineers – The New Audio Cyclopedia", Howard W. Sams & Company, 1987.
- [9] D. Davis and C. Davis, "Sound System Engineering", Howard W. Sams & Company, 1987.
- [10] R.H. Small, "Simplified Loudspeaker Measurements at Low Frequencies", J. Audio Eng. Soc., 1972 Jan/Feb.
- [11] D.B. Keele Jr, "Low Frequency Loudspeaker Assessment by Near-field Sound Pressure Measurements", J. Audio Eng. Soc., 1974 April.
- [12] W.D.T. Davies, "Generation and properties of maximum length sequences", Control, 1966 June/July/August.
- [13] F.J. MacWilliams and N.J.A. Sloane, "Pseudo-random sequences and arrays", Proc. IEEE, 1976 December.
- [14] M.R. Schroeder, "Integrated impulse method measuring sound decay without using impulses", J. Acoust. Soc. Am., 1979 August.
- [15] J. Borish and J.B. Angell, "An efficient algorithm for measuring the impulse response using pseudorandom noise", J. Audio Eng. Soc., 1983 July/August.
- [16] D.D. Rife, "Maximum length sequences optimize PC-based linear system analysis", Pers. Eng. Inst. News, 1987 May.
- [17] C. Dunn and M.O. Hawksford, "Distortion Immunity of MLS-Derived Impulse Response Measurements", J. Audio Eng. Soc., 1993 May.
- [18] R.H. Small, "Direct-Radiator Loudspeaker System Analysis", J. Audio Eng. Soc., 1972 June.
- [19] M.O. Hawksford, "Digital Signal Processing Tools for Loudspeaker Evaluation and Discrete-Time Crossover Design", J. Audio Eng. Soc., 1997 January/February.

- [20] D. Clarke, "Precision Measurement of Loudspeaker Parameters", J. Audio Eng. Soc., 1997 March.
- [21] IASCA - International Auto Sound Challenge Association Inc. - "Official Judging Rules".
- [22] A. Farina, "Simultaneous measurements of impulse response and distortion with a swept sine technique", AES Preprint n.5093, 108th Convention, 2000 February.
- [23] S. Mueller and P. Massarini, "Transfer function measurement with sweeps", J. Audio Eng. Soc., 2001 June.
- [24] T. Kite, "Measurements of audio equipment with log-swept sine chirps", AES Preprint n.6269, 117th Convention, 2004 October.
- [25] S. J. Loutridis, "Decomposition of Impulse Responses Using Complex Wavelets", JAES, Vol. 53, No. 9, 2005 September
- [26] D. B. Keele, "Time-Frequency Display of Electroacoustic Data Using Cycle-Octave Wavelet Transforms," 99th Convention AES, preprint 4136.
- [27] A. Mertins, "Signal Analysis: Wavelets, Filter Banks, Time-Frequency Transforms and Applications", 1999 J. Wiley.

NORMS

- [1] IEC 61672, Sound Level Meters (replacing former IEC 651, Sound level meters and IEC 804, Integrating-averaging sound level meters).
- [2] IEC 60268, Sound system equipment.
- [3] IEC 60386, Methods of measurement of speed fluctuations in sound recording and reproducing equipment.
- [4] ISO 226, Normal equal-loudness-level contours.
- [5] ISO 266, Preferred frequencies for measurements.
- [6] ISO 3382, Measurement of reverberation time of rooms with reference to other acoustical parameters.
- [7] IEC 61260, Octave-band and fractional-octave-band filters.
- [8] SMPTE RP120, Measurement of Intermodulation Distortion in Motion-Picture Audio Systems.

